



Z1022-XL

SANI-GARD AUTOMATIC TRAP PRIMER

SPECIFICATION SHEET

TAG _____

Dimensional Data (inches and [mm]) are Subject to Manufacturing Tolerances and Change Without Notice

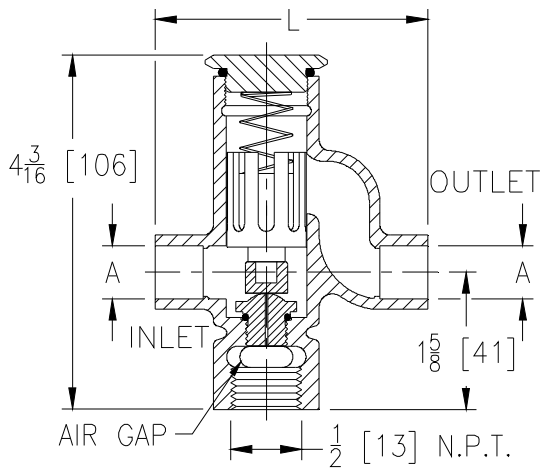

1/2 [13] PIPE SIZE

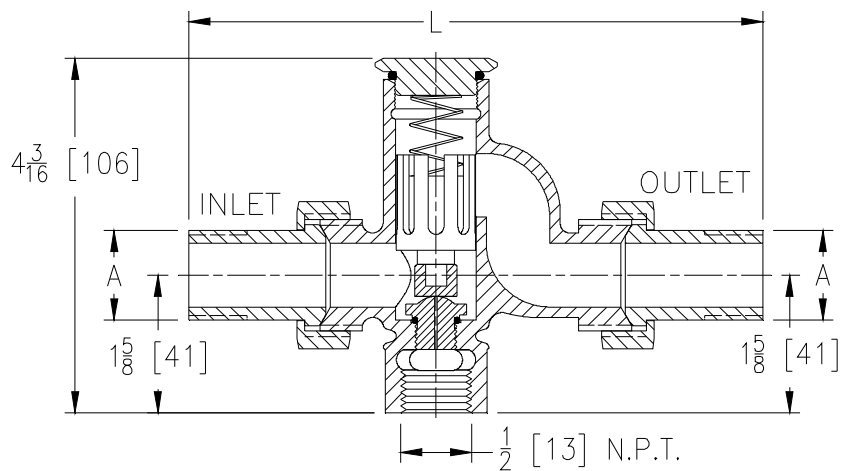

3/4 [19] PIPE SIZE

Dimensions In Inches		Approx. Wt. Lbs. [kg]
A Pipe Size/Connection	L	
1/2 [13] Solder Female	3-7/32 [82]	1 [.5]
1/2 [13] IP Female	3-7/32 [82]	1 [.5]
1/2 [13] Solder Female Union	5-21/32 [144]	1.5 [.75]
1/2 [13] IP Female Union	5-11/32 [136]	1.5 [.75]
3/4 [19] IP Male Union	6-13/16 [173]	2.0 [.9]

ENGINEERING SPECIFICATION: ZURN Z1022-XL

Sani-Gard Automatic Trap Primer, all bronze body with integral vacuum breaker, non-liming internal operating piston, stainless steel spring, removable bronze seat with metering orifice, and sealed bronze cover.

Zurn "XL" Lead-Free compliant products are a line of durable plumbing products designed and manufactured to comply with state laws and local codes that mandate maximum allowable lead content levels. Zurn "XL" products are manufactured in accordance to the Federal SWDA section 1417.

PIPE SIZE / CONNECTIONS (Specify size/type)

- _____ 1/2 [13] Solder Female
- _____ 1/2 [13] IP Female
- _____ 1/2 [13] Solder Female Union
- _____ 1/2 [13] IP Female Union
- _____ 3/4 [19] IP Male Union

PREFIXES

- _____ Z All Plain Bronze Body*

SUFFIXES

- _____ -CP Chrome Plated Finish
- _____ -DU2 2-Outlet Distribution Unit
- _____ -DU3 3-Outlet Distribution Unit
- _____ -DU4 4-Outlet Distribution Unit
- _____ -RK Repair Kit



* Regularly furnished unless otherwise specified.