

quality . service
innovation . integrity

810, 815 Series



"The color green is a registered trademark of Zoeller Pump Co."

Features

This series of submersible pumps is designed for use in residential or commercial wastewater applications and can be used to transfer wastewater or unscreened raw sewage. Each pump features an innovative cutting mechanism allowing it to grind solids into fine particles. The uniform consistency of the discharged material lessens the risk of clogs in the pipe, yielding less down time and fewer service calls. These durable cast iron pumps include a powder coated epoxy finish to prevent corrosion, and are designed to provide great heat dissipation from the motor. As with every Zoeller pump, each one is 100% factory tested to ensure quality and reliability for years of trouble free performance!

Specifications

Motor Characteristics

Motor	1 - 2 HP
Voltage	230 V
Phase	1 Ph
Hertz	60 Hz
RPM	1750 RPM
Type	Permanent split capacitor
Insulation	Class B
Amps	6.0 - 10.5 Amps

Pump Characteristics

Operation	Nonautomatic
Discharge Size	1-1/4" NPT
Cord Length	6 m (20') standard
Cord Type	3-wire neoprene
Max Operating Temp	54°C (130°F)
Cooling	Oil filled
Motor Protection	Auto reset thermal overload

Materials Characteristics

Cap	Cast iron
Motor Housing	Cast iron
Pump Housing	Cast iron
Base	Stainless steel stand
Upper Bearing	Ball bearing
Lower Bearing	Ball bearing
Mechanical Seals	Carbon and ceramic
Impeller Type	Hydraulic rotor
Impeller	Stainless steel
Hardware	Stainless steel
Motor Shaft	Stainless steel
Gasket	Neoprene

60 Hz



POWDER
COATED
TOUGH



Submersible Wastewater
Pump Association
SWPA
MEMBER



PUMP COMPANY

Zoeller Family of Water Solutions™

810, 815 Series

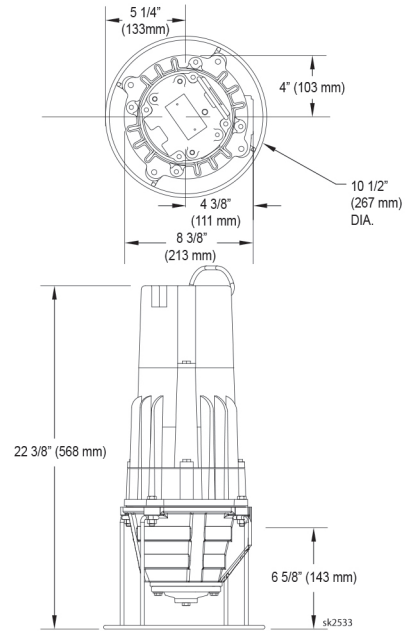
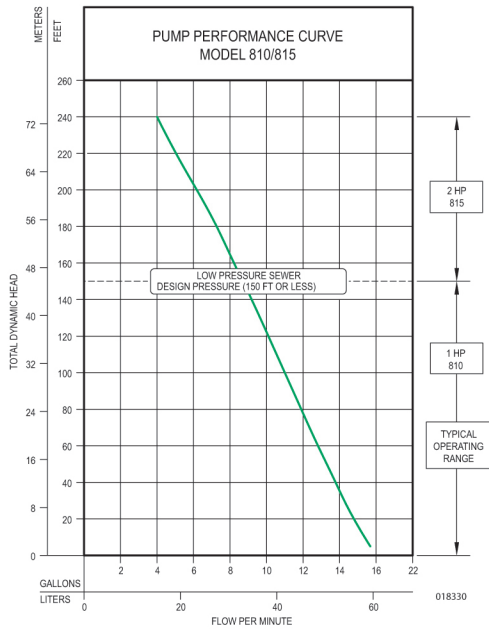

Model

Model Number	Mode	Volts	Phase	Amps	HP	Hz
E810	Non	230	1	7.0	1	60
E815	Non	230	1	10.5	2	60

Additional cord lengths are available in 8 m (25'), 11 m (35') and 15 m (50').

Your Peace of Mind is Our Top Priority®

3649 Cane Run Rd | Louisville, KY 40211 USA

+1 502-778-2731 | 1-800-928-7867 | Fax: +1 502-774-3624

www.zoeller.com