



# Westinghouse

## 316L Stainless Steel Light Commercial Electric Water Heater

**INDUSTRY  
BEST  
LIFETIME  
WARRANTY**  
(When Registered Online)

**No Anode  
Rods Needed**

**Lightweight  
and Durable**

**80, 100 & 115  
Gallon Tanks**



**Made in the USA**



**THERMOSTAT AND  
HIGH LIMIT CONTROLS:**  
**Commercial Temp:** min 120°F  
max 180°F

**TOP OF THE TANK  
CONNECTION:**  
Brass nipples with heat traps

**THE FINEST PROTECTION:**  
Laser welded through a concentrated heat source producing high quality, long lasting, 316L stainless steel tank construction (lightweight) - Superior corrosion resistance, eliminates the need for anode rods, protects against harsh water conditions for a lifetime of durability against leaks. Fantastic Limited Warranty

**MINIMAL HEAT LOSS:**  
Heavy-duty insulation

**STAINLESS STEEL &  
INCOLOY ELEMENTS:**  
Low watt density; Stainless steel screw plugs; Increases corrosion resistance for extended, longer element life

## BUILT TO LAST LONGER

# Dimensions & Specifications

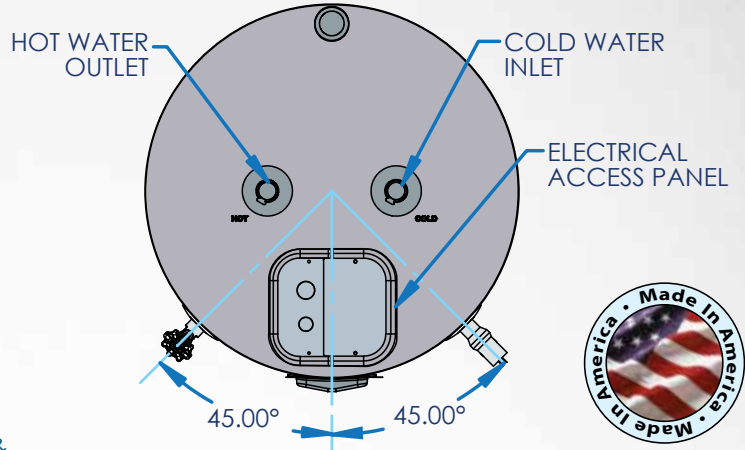
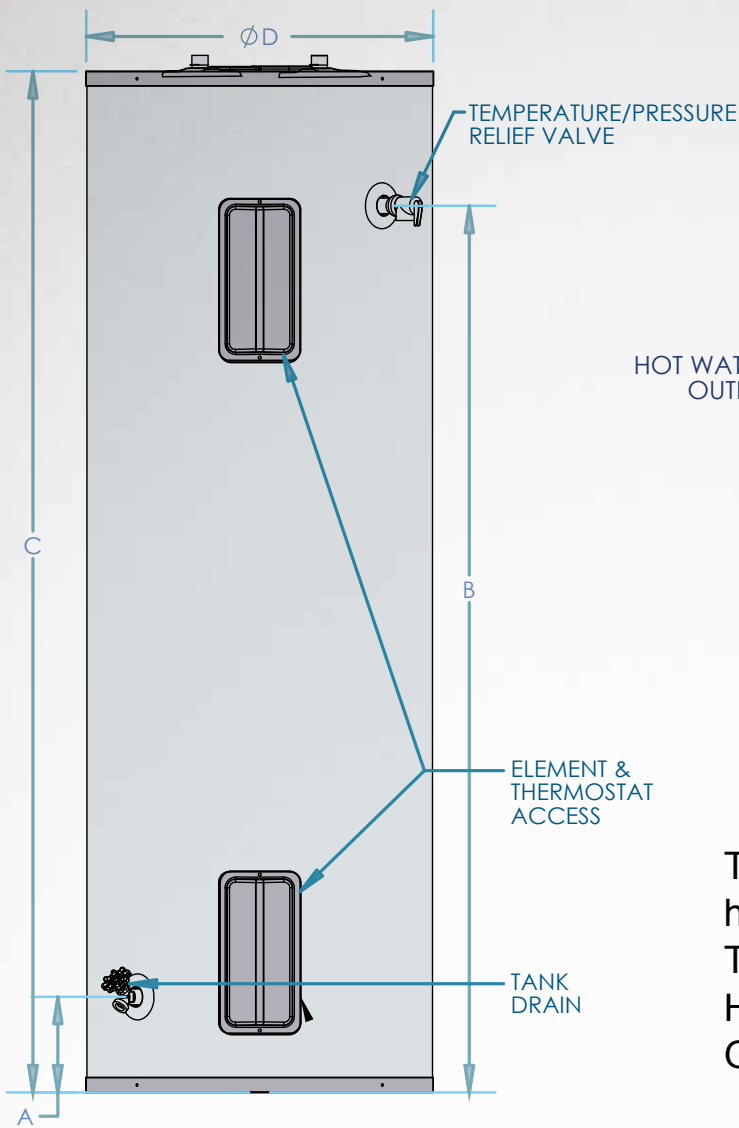

The Inlet & Outlet have Built in Heat Traps, Keeping the Heat in the Tank for Greater Efficiency

NO ANODE RODS NEEDED  
RESISTS SCALE BUILD UP  
LIGHT WEIGHT

SPECIFICATIONS AND DIMENSIONS						WATER TEMPERATURE RATINGS		
Models	Gal.	A	B	C	D	Minimum Delivered Temp.	Maximum Delivered Temp.	High Temp. Limit
WEC080C2X045	80	6.5"	60"	69"	23.25"	<b>120°F</b> 48.8°C	<b>180°F</b> 82.1°C	<b>200°F</b> 93.3°C
WEC080C2X055								
WEC100C2X045	100	7.25"	52"	61"	27"			
WEC100C2X055								
WEC115C2X045	115	7.25"	60.25	70.5"	27"			
WEC115C2X055								

Light Commercial Models	Wattage	Voltage	Safety Listing	First Hour Delivery	Recovery @ 90° F Rise	Thermal Efficiency	Shipping Weight
WEC080C2X045	4500	240	UL1453	84 Gallons	20 Gallons	98%	151 lbs
WEC080C2X055	5500			89 Gallons	25 Gallons		
WEC100C2X045	4500	240		87 Gallons	20 Gallons	98%	206 lbs
WEC100C2X055	5500			92 Gallons	25 Gallons		
WEC115C2X045	4500	240		105 Gallons	20 Gallons	98%	224 lbs
WEC115C2X055	5500			110 Gallons	25 Gallons		

Energy Factor based on D.O.E. (Department of Energy) test procedures. Heaters furnished with standard 240 volt AC, single phase non-simultaneous wiring.