

SPECIFICATION & SUBMITTAL SHEET

MODEL: AA-M

MEDIUM BASKET-STYLE SOLIDS INTERCEPTOR, 50 GPM

AARDVARK™ SERIES

TOP VIEW

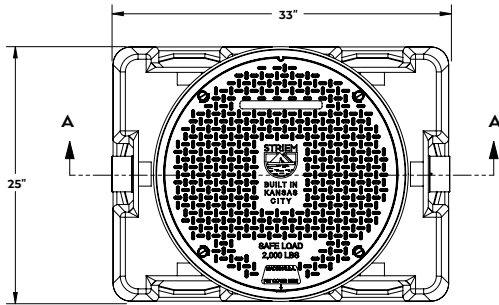

SECTION "A-A"

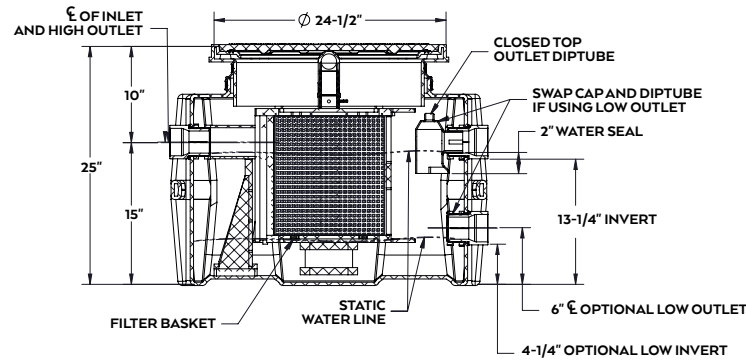

ISOMETRIC VIEW

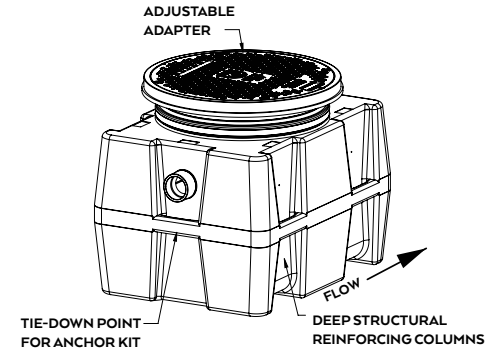

RISER ORDER GUIDE

DESIRED DEPTH	REQUIRED RISER	
	SR24	LR24
0" - 3-1/2"	INCLUDED	
> 3-1/2" - 22"	1	0
> 22" - 37"	0	1

OPTIONS:

- SR-24** - ADJUSTABLE RISER
- LR-24** - ADJUSTABLE RISER
- 3M** - 3" MPT CONNECTIONS
- 4P** - 4" PLAIN END CONNECTIONS*
- 4M** - 4" MPT CONNECTIONS*
- CC24** - MEMBRANE CLAMPING COLLAR KIT

* OPTIONAL SEWER GAS TRAP NOT COMPATIBLE WITH LOW OUTLET IF 4" SELECTIONS ARE SELECTED

STANDARD SPECS

CONNECTIONS: 3" SCH. 40 PLAIN END INLET/OUTLETS

LIQUID CAPACITY: < HIGH: 38 GAL.
LOW: 12 GAL.

SOLIDS CAPACITY: 6 GAL.

WEIGHT: 83 LBS.

INSTALLATION: ABOVE OR BELOW GRADE

SEWER GAS TRAP: 2"

COVER LOAD CAPACITY: 2,000 LBS.

MAX CONTINUOUS OPERATING TEMPERATURE: 190°

WALL THICKNESS: 3/8"

TANK MATERIAL: SEAMLESS HIGH DENSITY POLYETHYLENE

SCREEN PERFORATIONS: 0.1" X 0.08"

INNOVATIONS

- 1 **Removable basket interlocks with inlet:** prevents solids from escaping basket.
- 2 **UNI-FIT™:** basket only fits in one orientation.
- 3 **All-perforated basket:** basket perforations are more than 9 times inlet opening, creating easy flow in the presence of solids, and limiting the chance for a backup.
- 4 **Optional low outlet:** if used, it allows for a temporary water surge (acts as a reservoir), as well as keeps basket dry during maintenance.
- 5 **Movable trap:** sewer gas trap can be field-installed on high or low outlet.
- 6 **Field adjustable basket handle:** handle can be extended for deeper burials.

ENGINEER SPECIFICATION GUIDE

Striem Aardvark™ solids interceptor model AA-M shall be lifetime guaranteed and made in the USA. Tank material shall be polyethylene. Interceptor shall have removable, corrosion-resistant filter basket. Interceptor shall be equipped with high and low outlet options, with a movable sewer gas trap to be located on either outlet. Interceptor shall be furnished for above- or below-grade burial. Cover shall be water and gas tight with a minimum 2,000 lbs. load capacity. Interceptor shall be in compliance with IAPMO IGC 167-2011ae2.

Signature of Approval: _____

Company: _____

Date of Approval: _____

Specifying Engineer: _____

Engineering Firm: _____



3100 Brinkerhoff
Kansas City, KS 66115

PH 913-222-1500

FX 913-291-0457

STRIEMCO.COM

MADE IN THE U.S.A.



LIFETIME GUARANTEED

PROPRIETARY AND CONFIDENTIAL - THE INFORMATION CONTAINED IN THIS DRAWING IS THE SOLE PROPERTY OF STRIEM, LLC. ANY REPRODUCTION IN PART OR AS A WHOLE WITHOUT THE WRITTEN PERMISSION OF STRIEM, LLC. IS PROHIBITED.

DATE: 10/2/18