

SPEAKMAN®

SEF-1801

Eyesaver® Laboratory Widespread Faucet with Integrated Eyewash

SPECIFICATION

The Speakman SEF-1801 is a NSF 61 compliant widespread laboratory faucet with an integrated ANSI compliant aerated eyewash. Dedicated water ways allow the faucet and eyewash to work independently of each other.

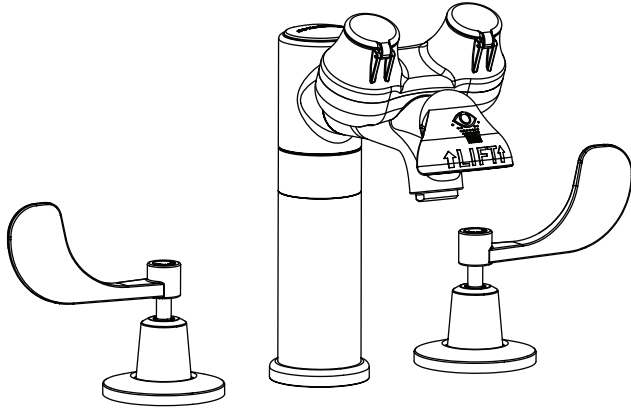

EYEWASH FEATURES:

- Lift handle activator
- Dedicated water channel for eyewash
- Aerated plated spray outlets with flip-top dust caps
- 2 gpm (7.57 L/min) flow rate at 30 PSI
- Tepid water ready

FAUCET FEATURES:

- Lead-free brass construction
- ¼ turn ceramic cartridges
- Cross handles with color-coded indexes
- Swivel or rigid spout up to 100 degrees
- Widespread installation
- 1.5 gpm (5.7 L/min) flow rate

COMPLIANCE:

- Certified to ANSI/ISEA Z358.1, ASME A112.18.1/CSA B125.1, NSF 61 & NSF 372

FINISHES:

ADD SUFFIX TO MODEL #

- Polished Chrome (standard)

OPTIONS:

- 8 in. deep gooseneck rigid or swivel -8
- 0.5 gpm vandal-resistant flow control outlet -BO
- Foot pedal activation (not NSF 372 compliant) -FP
- 1.5 gpm laminar flow for faucet outlet -LF
- Non-aerated eyewash spray outlets and laminar flow control -NA
- Serrated tip with vacuum breaker (not NSF 372 compliant) -ST
- Se-370 thermostatic mixing valve -TW
- Under-counter TMV (electronic only) for faucet temp. -TMV

WARRANTY:

- 25 years for ceramic cartridges
- 3 year limited

SEE REVERSE FOR ROUGH-IN DIMENSIONS
PATENT PENDING

THIS SPACE FOR ARCHITECT/ENGINEER APPROVAL.

SPEAKMAN®

400 ANCHOR MILL ROAD | NEW CASTLE, DE 19720
P: 800-537-2107 | F: 800-977-2747
WWW.SPEAKMANCOMPANY.COM

REVISION DATE: JUNE 2014



Management Systems
Registered to ISO 9001

SPEAKMAN®

Eyesaver® Laboratory Widespread Faucet with Integrated Eyewash SEF-1801

SPECIFICATION

FRONT VIEW

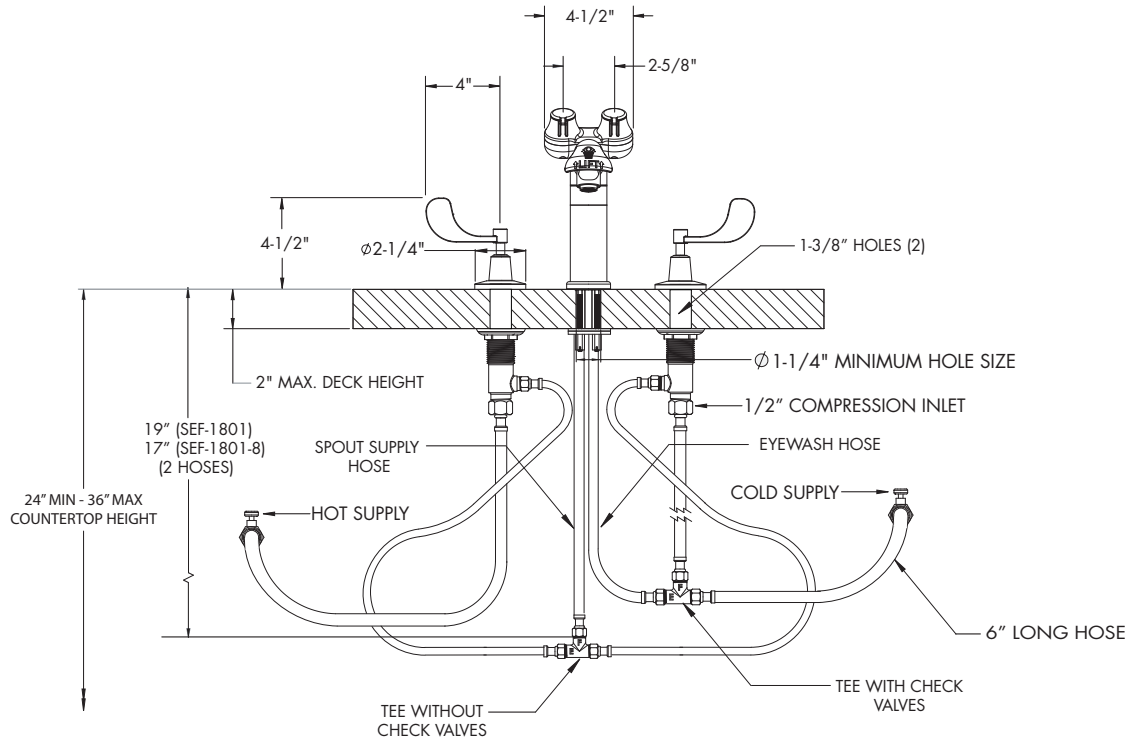

SEF-1801 SIDE VIEW (LESS HOSES)

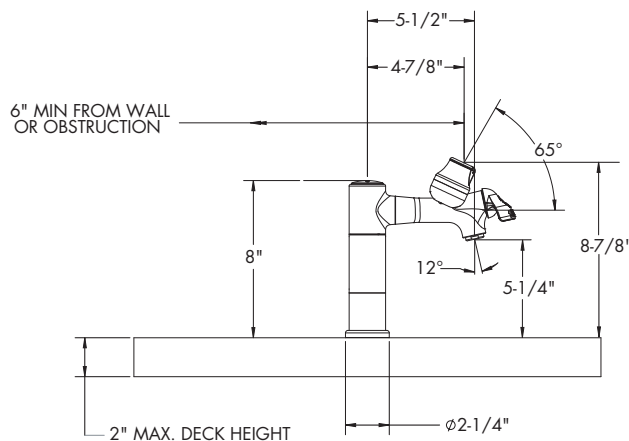

NOTE: 1. Unless otherwise specified, all inlets are 3/8" compression with female threads. 2. All dimensions are in inches (millimeters) unless otherwise specified and are subject to change without notice.

THIS SPACE FOR ARCHITECT/ENGINEER APPROVAL.

SPEAKMAN®

400 ANCHOR MILL ROAD | NEW CASTLE, DE 19720
 P: 800-537-2107 | F: 800-977-2747
 WWW.SPEAKMANCOMPANY.COM



Management Systems
 Registered to ISO 9001

REVISION DATE: JUNE 2014