

SPEAKMAN®

Wall Mounted Round Eye/Face Wash Bowl

SE-490
SE-490-SS

SPECIFICATION

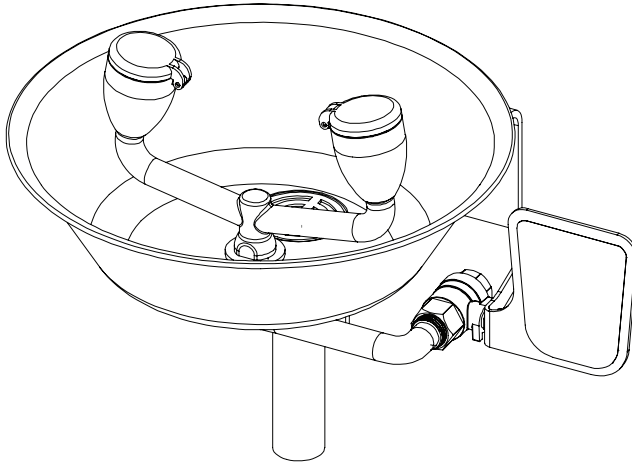

MODELS:

- SE-490: Stainless steel bowl with dual soft flowing eye/face wash spray heads
- SE-490-SS: All stainless steel components with dual soft flowing eye/face wash spray heads

FEATURES:

- (2) yellow plastic spray outlets with flip-top dust caps
- 300 series stainless steel bowl
- ½ in. NPT female brass, chrome-plated valve (SE-490)
- ½ in. NPT female stainless steel, chrome-plated valve (SE-490-SS)
- Stainless steel push handle activator
- ½ in. NPT female inlet
- 4.5 gpm @ 30 psi
- Universal emergency sign included

COMPLIANCE:

- Certified to ANSI/ISEA Z358.1

FINISHES:

- DuraJade™ (SE-490)
- Stainless steel (SE-490-SS)

OPTIONS:

ADD SUFFIX TO MODEL #

- | | |
|----------------------------------------------------------------|---------------------------------|
| <input type="checkbox"/> Stainless steel cover | <input type="checkbox"/> -CV |
| <input type="checkbox"/> Freeze protection valve | <input type="checkbox"/> -FPV |
| <input type="checkbox"/> Hand/foot operation | <input type="checkbox"/> -HFO |
| <input type="checkbox"/> SE-920 hand held drench hose | <input type="checkbox"/> HS |
| <input type="checkbox"/> In-line strainer for ½ in. IPS piping | <input type="checkbox"/> -ILS |
| <input type="checkbox"/> P-Trap | <input type="checkbox"/> -PT |
| <input type="checkbox"/> Scald protection valve | <input type="checkbox"/> -SPV |
| <input type="checkbox"/> ½ in. stainless steel ball valve | <input type="checkbox"/> -SSBV2 |

WARRANTY:

- 3 year limited

SEE REVERSE FOR ROUGH-IN DIMENSIONS

THIS SPACE FOR ARCHITECT/ENGINEER APPROVAL.

SPEAKMAN®

400 ANCHOR MILL ROAD | NEW CASTLE, DE 19720
P: 800-537-2107 | F: 800-977-2747
WWW.SPEAKMANCOMPANY.COM

REVISION DATE: SEPTEMBER 2014



Management Systems
Registered to ISO 9001

SPEAKMAN®

Wall Mounted Round Eye/Face Wash Bowl SE-490, SE-490-SS

SPECIFICATION

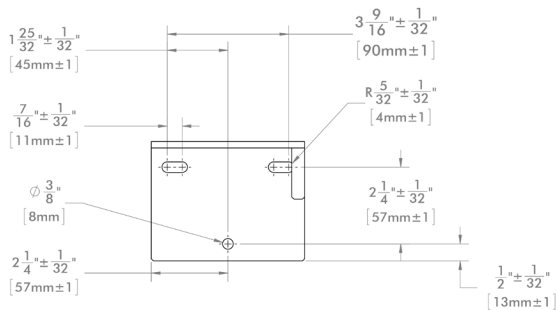
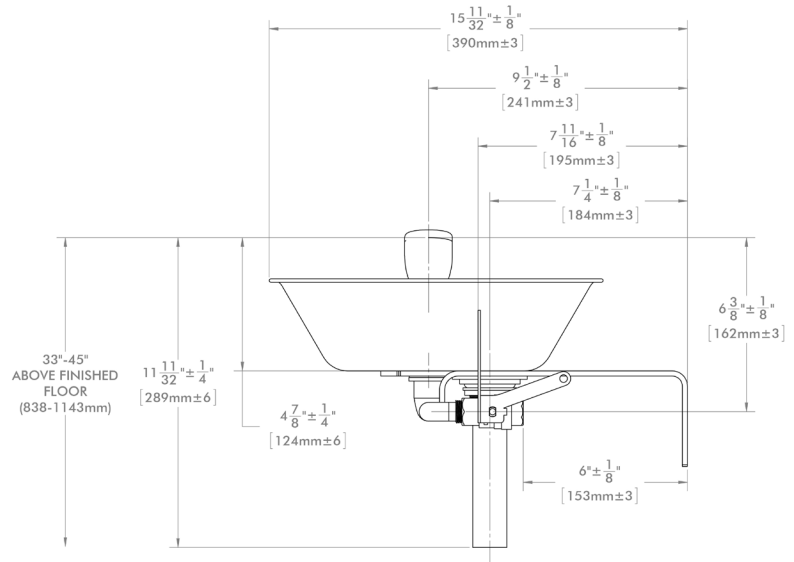
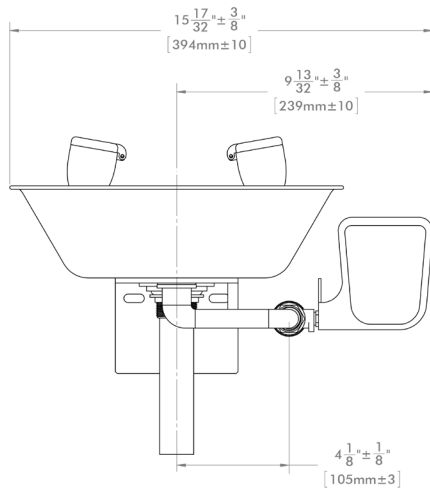

NOTE: 1. All dimensions are in inches (millimeters) unless otherwise specified and are subject to change without notice.

THIS SPACE FOR ARCHITECT/ENGINEER APPROVAL.

SPEAKMAN®

400 ANCHOR MILL ROAD | NEW CASTLE, DE 19720
 P: 800-537-2107 | F: 800-977-2747
 WWW.SPEAKMANCOMPANY.COM

REVISION DATE: SEPTEMBER 2014



Management Systems
 Registered to ISO 9001