

FEATURES:

- Independent eye wash & face wash integrated into one, multi-functioning safety unit
- Aerated sprays for eyewash comfort & innovative face pads for full face cleansing
- Flip top dust caps
- Stainless Steel bowl
- ½ in. NPT female brass, chrome-plated, full flow stay-open ball valve
- Stainless steel push handle activator
- ½ in. NPT female inlet
- Integral in-line strainer
- 4.9 gpm @ 30 psi
- Can be installed in either standard height or ADA configuration.
- Patent Pending
- Universal Emergency Sign Included

COMPLIANCE:

- Certified to ANSI Z358.1
- Wheelchair accessible when installed accordingly



OPTIONS:

ADD SUFFIX TO MODEL #

- Anti-freeze protection valve -FPV
- Hand & foot operation -HFO
- Hand-held spray -HS
- In-line strainer -ILS
- P-trap -PT
- Scald protection valve -SPV

WARRANTY:

- 3 year limited

SEE REVERSE FOR ROUGH-IN DIMENSIONS

THIS SPACE FOR ARCHITECT/ENGINEER APPROVAL.

SPEAKMAN®

400 ANCHOR MILL ROAD | NEW CASTLE, DE 19720
P: 800-537-2107 | F: 800-977-2747
WWW.SPEAKMANCOMPANY.COM

REVISION DATE: APRIL 2014



Management Systems
Registered to ISO 9001

SPEAKMAN®

Optimus™ Wall Mounted Eye and Face Wash Bowl SE-1050

SPECIFICATION

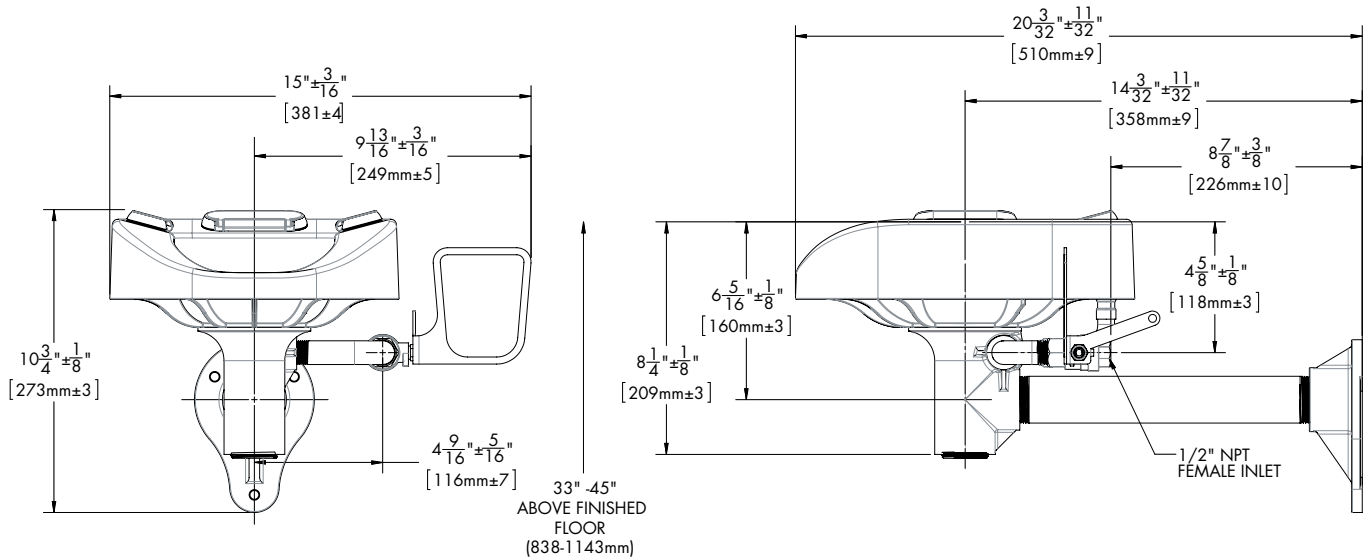
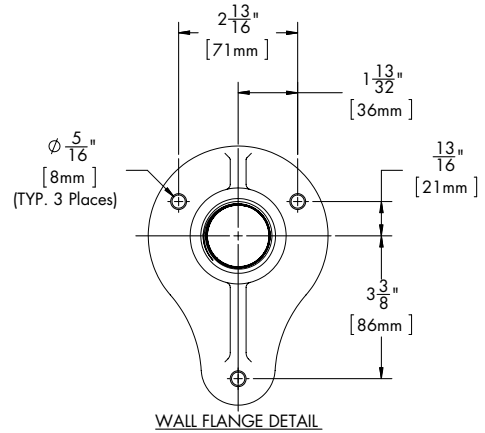
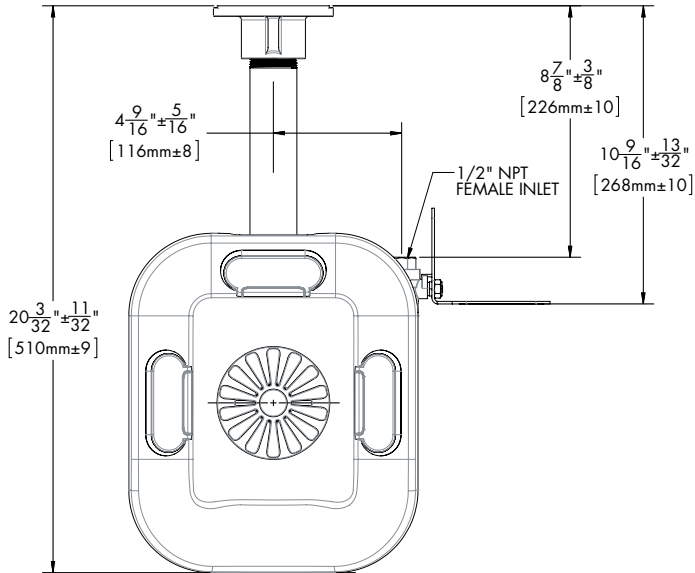

33" - 45"
ABOVE FINISHED
FLOOR
(838-1143mm)

36" (914mm) MAXIMUM
ABOVE FINISHED FLOOR
FOR ADA INSTALLED UNITS

NOTE: 1. All dimensions are in inches (millimeters) unless otherwise specified and are subject to change without notice.

THIS SPACE FOR ARCHITECT/ENGINEER APPROVAL.

SPEAKMAN®

400 ANCHOR MILL ROAD | NEW CASTLE, DE 19720
P: 800-537-2107 | F: 800-977-2747
WWW.SPEAKMANCOMPANY.COM



Management Systems
Registered to ISO 9001

REVISION DATE: APRIL 2014