

► **Code Number**

3379001

► **SPECIFICATIONS**

**Description**

- Battery Powered, Sensor Activated, Sloan® Optima® Plus Model Retrofit Conversion Kit for Exposed Closet Flushometers.

**Specifications**

- Initial Set-up Range Indicator Light (first 10 minutes)
- User friendly three (3) second Flush Delay
- "Low Battery" Flashing LED
- Installation Tools provided
- Infrared Sensor with Multiple-focused, Lobular Sensing Fields for high and low target detection
- Latching Solenoid Operator
- Chrome Plated Metal Handle Cap
- Engineered Plastic Cover with replaceable Lens Window
- Quiet, Exposed, OPTIMA Plus®, Battery Powered, Sensor Activated Closet Flushometer Retrofit Conversion Kit for Sloan Royal® and Regal® Flushometers with the following features:
- ADA Compliant Battery Powered Infrared Sensor for automatic "Hands-free" operation
- Courtesy Flush® Override Button
- High Chloramine Resistant PERMEX® Synthetic Rubber Diaphragm with Linear Filtered Bypass and Vortex Cleansing Action™
- Four (4) Size AA Batteries included

**Flush Cycle**

- 1.6 gpf/6.0Lpf
- 3.5 gpf/13.2 lpf

**Accessories (Sold Separately)**

- See Accessories Section and OPTIMA® Accessories Section of the Sloan catalog for details on these and other OPTIMA® Flushometer variations.

► **ELECTRICAL SPECIFICATIONS**

**Control Circuit**

- Solid State
- 6 VDC Input
- 8 Second Arming Delay
- 3 Second Flush Delay

**Indicator Lights**

- Range Adjustment

**Battery Type**

- (4) AA Alkaline

**Battery Life**

- 6 Years @ 4,000 flushes/month

**Sentinel Flush**

- Automatic flush once every 72 hours after the last flush. Product shipped from factory with feature turned off. Consult factory to activate.

**Sensor Range**

- Nominal 22" - 42" (559 mm - 1067 mm) Self-adaptive Window: ± 10" (254 mm)



► **FEATURES**

**Automatic Operation**

- Sloan Optima Plus® Flushometers activate via multi-lobular sensor detection to provide the ultimate in sanitary protection and automatic operation. A battery powered infrared sensor sets the flushing mechanism after the user is detected and Completes the flush when the user steps away.

**Hygienic**

- User makes no physical contact with the Flushometer surface except to initiate the Override Button when required. Helps control the spread of infectious diseases.

**Economical**

- Automatic operation provides water usage savings over other flushing devices. Reduces maintenance and operation costs.

► **Compliance & Certifications**



This space for Architect/Engineer Approval

► **ROUGH-IN**

### Sensor Type

- Active Infrared

### Operating Pressure

- 15 - 100 psi (104 - 689 kPa)

### ► OPERATION



1. A continuous, invisible light beam is emitted from the OPTIMA Plus Sensor.

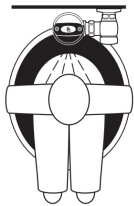

2. As the user enters the beam's effective range (22" to 42") the beam is reflected into the OPTIMA Plus Scanner Window and transformed into a low voltage electrical circuit. Once activated, the Output Circuit continues in a "hold" mode for as long as the user remains within the effective range of the Sensor.



3. When the user steps away from the OPTIMA Plus® Sensor, the circuit waits 3 seconds (to prevent false flushing) then initiates an electrical signal that operates the Solenoid. This initiates the flushing cycle to flush the fixture. The Circuit then automatically resets and is ready for the next user.

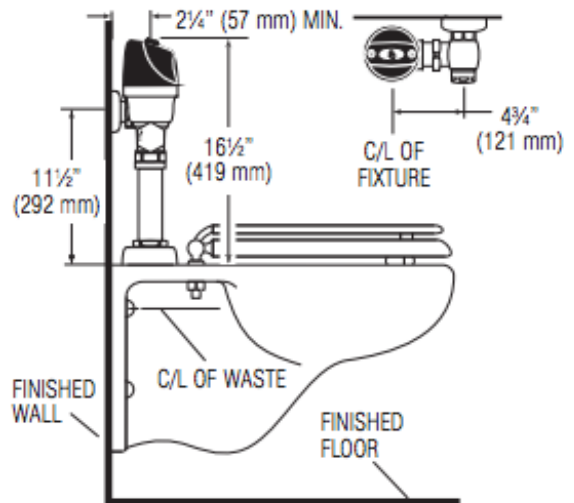
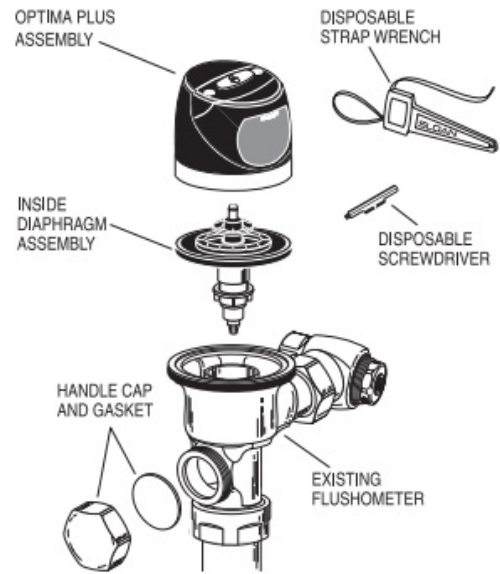

When installing the Optima Plus in a handicap stall: Per the ADA Guidelines (section 604.9.4) it is recommended that the grab bars be split or shifted to the wide side of the stall.