

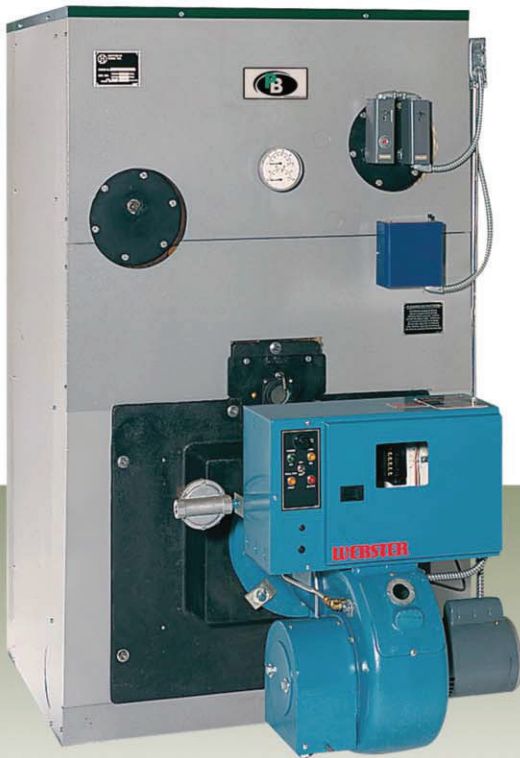

Series LC™ & Series LCE™

Large Commercial Boilers



Standard Equipment

- > Manual Reset High Limit Control
- > Honeywell Operating Control
- > LWCO on Packaged Boilers
- > Safety Relief Valve (30 psi – Water; 15 psi – Steam)
- > Combination Temperature-Pressure Gauge (Water)
- > Operating Pressuretrol (Steam)
- > Gauge Glass with Fittings (Steam)

Series LC™ & Series LCE™ Boiler Features

- Oil, Gas or Combination Gas/Oil-Fired Boilers for Hot Water or Steam Systems
- 22 sizes, 4–24 sections; Available as Knockdown, Factory Assembled Sections or Factory Packaged
- Up to 84.2% Combustion Efficiency—Boiler Efficiencies Compliant with Federal and ASHRAE 90.1 Requirements
- Forced Draft Venting—Requires Only a Three Foot Vent Above the Roof
- Advanced Boiler Design that Includes Integral Cast Iron Flue Collector, Unique Flex-Seal Gaskets and Individual Draw Rods
- Cast Iron Rear Outlet with Integral Damper (4-12 section models)—can be Adjusted and Locked in Position
- Cast Iron Top Outlet with Butterfly Flue Damper (13-24 section models)—can be Mounted Horizontally or Vertically
- Optional LoNOx, SCAQMD Certified (LC-04 - LC-10 Models)
- Optional Tankless Domestic Hot Water Coils Available for all Models

All commercial cast iron boilers include a full one-year warranty. A limited, ten-year warranty is provided for the cast iron sections of commercial hot water and steam boilers. Visit PeerlessBoilers.com for complete details.

Steam Piping

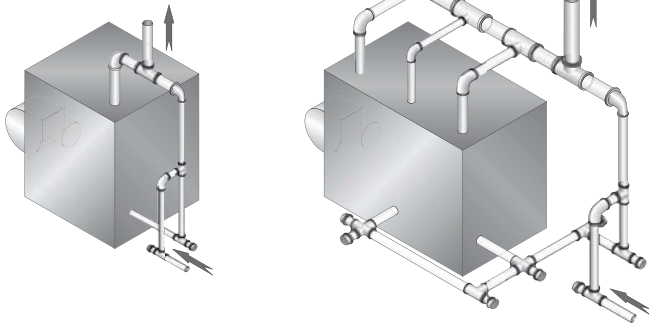

Pipe the return line to a Hartford Loop, with the return nipple located from 2 to 4 inches below the normal water line.

Water Piping

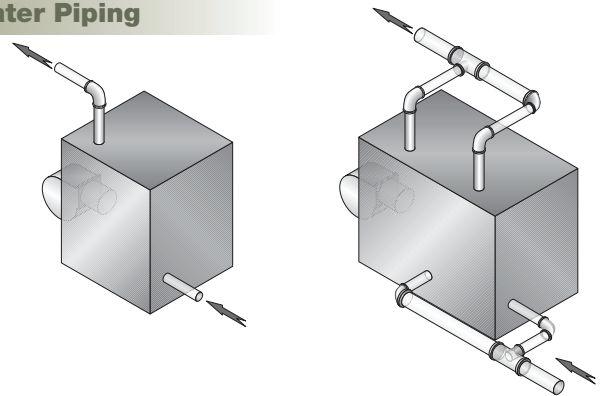

Size the supply and return headers to meet the system flow requirement.

Boiler Piping (Steam)

Boiler Model Number	Risers	Minimum Header Size	Equalizer
LC-04	1-4"	4"	2"
LC-05R	2-3"	5"	2"
LC-05	2-3"	5"	2"
LC-06	2-4"	5"	2"
LC-07	2-4"	5"	2-1/2"
LC-08	2-4"	6"	2-1/2"
LC-09	2-4"	6"	2-1/2"
LC-10	2-4"	6"	2-1/2"
LC-11	2-4", 1-3"	6"	3"
LC-12	2-4", 1-3"	6"	3"
LCE-13	2-4", 1-3"	6"	3"
LCE-14	2-4", 2-3"	8"	3"
LCE-15	2-4", 2-3"	8"	3"
LCE-16	2-4", 2-3"	8"	3"
LCE-17	2-4", 3-3"	8"	4"
LCE-18	2-4", 3-3"	8"	4"
LCE-19	2-4", 3-3"	8"	4"
LCE-20	2-4", 3-3"	8"	4"
LCE-21	2-4", 4-3"	8"	4"
LCE-22	2-4", 4-3"	8"	4"
LCE-23	2-4", 4-3"	8"	4"
LCE-24	2-4", 4-3"	8"	4"

Boiler Piping (Water)

Boiler Model Number	Supply	Return	Minimum Header Size
LC-04, 05R, 05	1-2-1/2"	1-2-1/2"	2-1/2"
LC-06 and LC-07	1-3"	1-3"	3"
LC-08 and LC-09	2-3"	2-3"	3"
LC-10 thru LC-12	2-4"	2-3"	4"

Tankless Domestic Hot Water Heater Locations

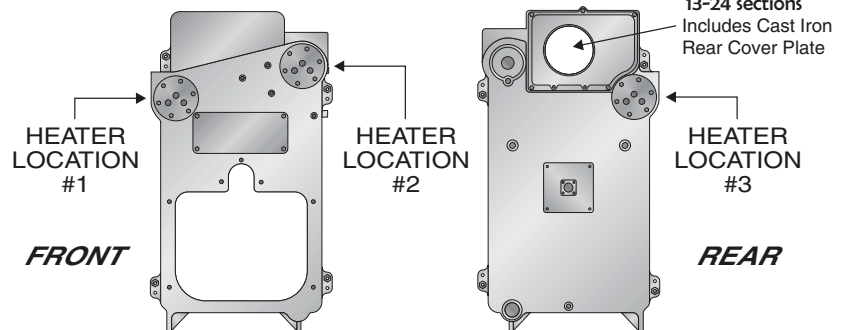

Tankless Domestic Hot Water Heater Ratings*

Boiler Model Number	Heater No. X-1020			Heater No. X-1022			Two Heater No. X-1020			Two Heater No. X-1022		
	GPM	Location**		GPM	Location**		GPM	Location**		GPM	Location**	
		Steam	Water		Steam	Water		Steam	Water		Steam	Water
LC-04	5.5	1	2	—	—	—	8.0	—	1 & 2	—	—	—
LC-05R	5.62	1	2	—	—	—	9.0	—	1 & 2	—	—	—
LC-05	5.75	1	2	—	—	—	10.0	—	1 & 2	—	—	—
LC-06	6.25	1	2	—	—	—	12.0	—	1 & 2	—	—	—
LC-07	6.5	1	2	13.0	1	2	13.0	—	1 & 2	15.5	—	1 & 2
LC-08	7.0	1	2	13.75	1	2	14.0	—	1 & 2	18.0	—	1 & 2
LC-09	7.25	1	2	14.5	1	2	14.5	1 & 3	1 & 2	20.0	—	1 & 2
LC-10	7.5	1	2	15.5	1	2	15.0	1 & 3	1 & 2	22.5	—	1 & 2
LC-11	8.0	1	2	16.5	1	2	16.0	1 & 3	1 & 2	24.5	—	1 & 2
LC-12	—	—	—	17.5	1	2	—	—	—	27.0	—	1 & 2
LCE-13	—	—	—	18.0	1	—	—	—	—	29.0	—	—
LCE-14	—	—	—	18.75	1	—	—	—	—	31.5	—	—
LCE-15	—	—	—	19.5	1	—	—	—	—	33.5	1 & 3	—
LCE-16	—	—	—	20.0	1	—	—	—	—	35.5	1 & 3	—
LCE-17	—	—	—	20.0	1	—	—	—	—	37.5	1 & 3	—
LCE-18	—	—	—	20.0	1	—	—	—	—	39.5	1 & 3	—
LCE-19	—	—	—	20.0	1	—	—	—	—	40.0	1 & 3	—
LCE-20	—	—	—	20.0	1	—	—	—	—	40.0	1 & 3	—
LCE-21	—	—	—	20.0	1	—	—	—	—	40.0	1 & 3	—
LCE-22	—	—	—	20.0	1	—	—	—	—	40.0	1 & 3	—
LCE-23	—	—	—	20.0	1	—	—	—	—	40.0	1 & 3	—
LCE-24	—	—	—	20.0	1	—	—	—	—	40.0	1 & 3	—

* Water heater ratings are based on intermittent demand—40° F to 140° F Rise with 200° F boiler water.

** Water heater locations may be found on the drawing above.

When two (2) tankless water heaters are used in a steam boiler, a special rear section is furnished at no extra charge—when ordered with boiler.

Caution: Water mixing valve should always be installed in the hot water supply to prevent injury.

4-12 sections

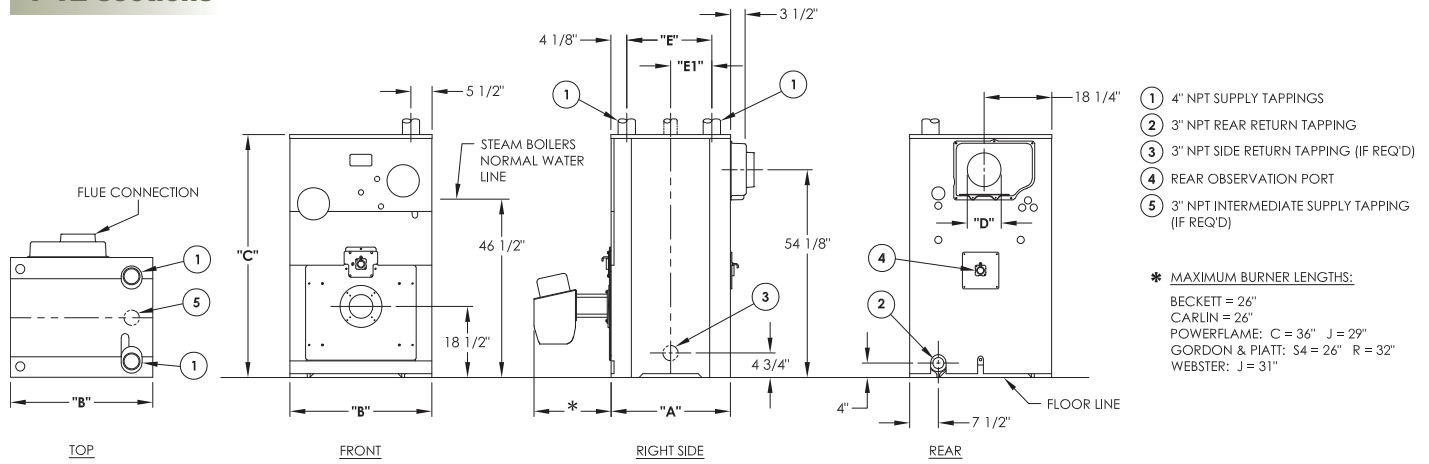

13-24 sections

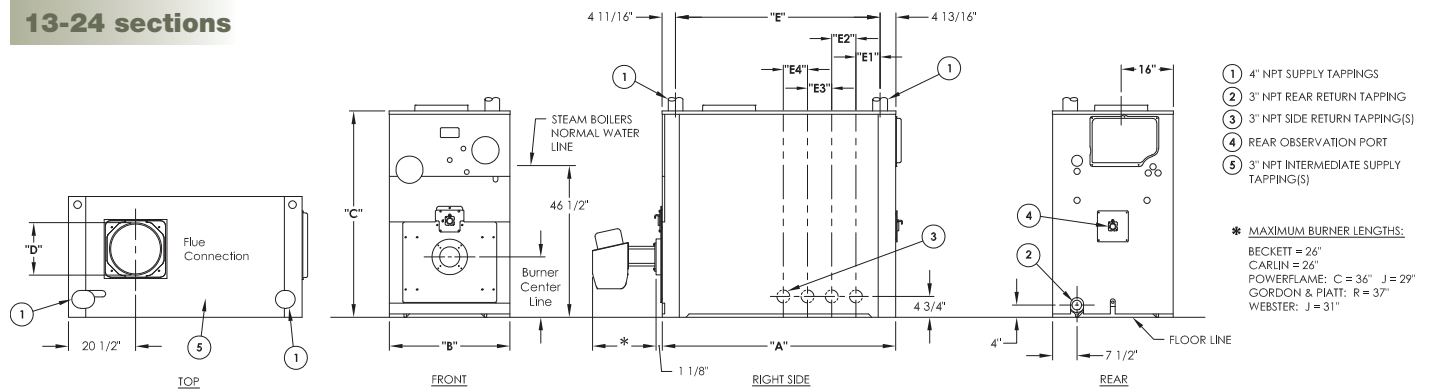

Boiler Dimensions and Tapping Locations

Boiler Model Number	Jacket Depth "A"	Jacket Width "B"	Jacket Height "C"	Flue Size "D"	Distance Between Tappings*					
					"E"	Water		Steam		
						"E1"	"E1"	"E2"	"E3"	"E4"
LC-04	25-15/16"	37"	63"	9"	16-1/2"	—	—	—	—	—
LC-05R	31"	37"	63"	9"	21-9/16"	—	—	—	—	—
LC-05	31"	37"	63"	9"	21-9/16"	—	—	—	—	—
LC-06	36-1/16"	37"	63"	10"	26-5/8"	—	—	—	—	—
LC-07	41-1/8"	37"	63"	10"	31-11/16"	—	—	—	—	—
LC-08	46-5/16"	37"	63"	10"	36-13/16"	15-13/16"	—	—	—	—
LC-09	51-3/8"	37"	63"	12"	41-7/8"	20-15/16"	—	—	—	—
LC-10	56-7/16"	37"	63"	12"	46-15/16"	20-15/16"	—	—	—	—
LC-11	61-1/2"	37"	63"	12"	52"	26"	26"	—	—	—
LC-12	66-9/16"	37"	63"	12"	57-1/8"	26"	26"	—	—	—
LCE-13	71-3/4"	37"	63"	14"	62-3/16"	—	36-3/16"	—	—	—
LCE-14	76-13/16"	37"	63"	14"	67-1/4"	—	20-5/16"	20-5/16"	—	—
LCE-15	81-7/8"	37"	63"	14"	72-5/16"	—	26"	20-5/16"	—	—
LCE-16	86-15/16"	37"	63"	14"	77-7/16"	—	26"	25-7/16"	—	—
LCE-17	92-1/8"	37"	63"	14"	82-1/2"	—	20-5/16"	20-5/16"	15-1/4"	—
LCE-18	97-3/16"	37"	63"	16"	87-9/16"	—	20-5/16"	20-5/16"	20-5/16"	—
LCE-19	102-1/4"	37"	63"	16"	92-5/8"	—	20-5/16"	20-5/16"	25-7/16"	—
LCE-20	107-7/16"	37"	63"	16"	97-3/4"	—	20-5/16"	20-5/16"	15-1/4"	15-1/4"
LCE-21	112-1/2"	37"	63"	16"	102-13/16"	—	20-5/16"	20-5/16"	20-5/16"	15-1/4"
LCE-22	117-9/16"	37"	63"	16"	107-7/8"	—	20-5/16"	20-5/16"	20-5/16"	20-5/16"
LCE-23	122-5/8"	37"	63"	16"	112-15/16"	—	26"	20-5/16"	20-5/16"	20-5/16"
LCE-24	127-11/16"	37"	63"	16"	118-1/16"	—	26"	20-5/16"	20-5/16"	25-7/16"

Apply Prefix "O" for oil—"G" for gas—"GO" for gas-oil.

* Dimensions are approximate.

The manufacturer should be consulted before selecting a boiler for installations having unusual piping and pickup requirements, such as intermittent system operation, extensive piping, etc. For forced hot water heating systems where the boiler and all the piping are within the area to be heated, the boiler may be selected on the basis of its Gross Output.

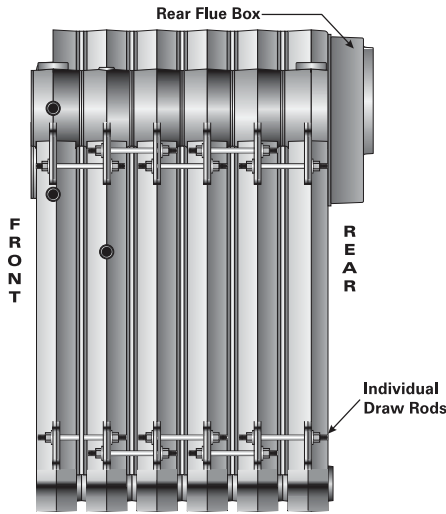

Cast Iron Block Assembly-Rear Flue Outlet

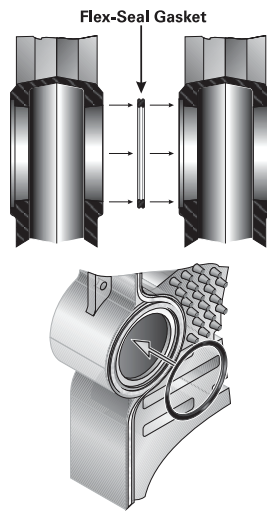

Flex-Seal Gaskets

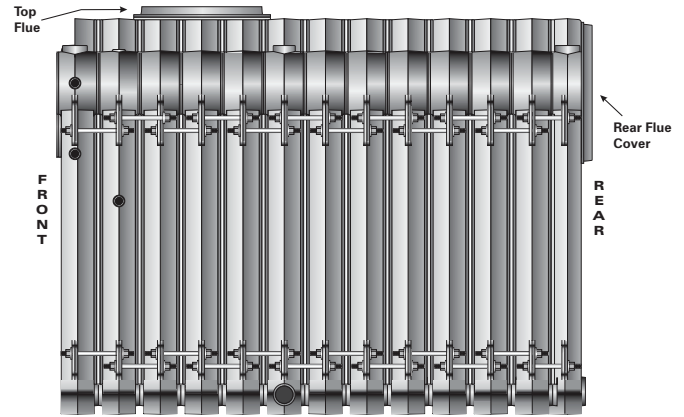

Cast Iron Block Assembly-Top Flue Outlet

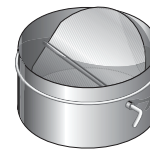

Butterfly Flue Damper (13-24 sections)
Mounted Horizontally or Vertically

Boiler Ratings

Series LC™ & Series LCE™



Boiler Model Number	Oil Input ¹		Gas Input, MBH	Gross Output, MBH	Net Ratings ⁴			Oil		Gas		Boiler H.P.	Water Content, gal	
	GPH	MBH			Steam, sqft	Water ² , MBH	Steam ³ , MBH	Combustion Efficiency ⁵ , %	Thermal Efficiency ⁵ , %	Combustion Efficiency ⁵ , %	Thermal Efficiency ⁵ , %		Water	Steam
LC-04-S	4.75	665	686	547	1,708	—	410	83.7	82.2	81.2	79.8	16.3	—	40.57
LC-04-W	4.75	665	686	547	—	476	—	84.2	82.9	81.6	80.4	16.3	50.65	—
LC-05R	5.60	784	808	649	2,029	564	487	83.7	82.8	81.2	80.3	19.4	59.05	47.29
LC-05	6.10	854	881	707	2,208	615	530	83.7	82.8	81.2	80.3	21.1	59.05	47.29
LC-06	7.50	1,050	1,077	868	2,713	755	651	83.7	83.1	81.1	80.6	25.9	67.45	54.01
LC-07	8.80	1,232	1,273	1,029	3,217	895	772	83.6	83.3	81.1	80.8	30.7	75.85	60.73
LC-08	10.20	1,428	1,469	1,189	3,717	1,034	892	83.6	83.5	81.1	81	35.5	84.25	67.45
LC-09	11.60	1,624	1,664	1,350	4,250	1,174	1,020	83.6	83.6	81.1	81.1	40.3	91.65	74.17
LC-10	12.80	1,792	1,860	1,511	4,804	1,314	1,153	83.6	83.7	81.1	81.2	45.1	101.05	80.89
LC-11	14.20	1,988	2,056	1,672	5,367	1,454	1,288	83.6	83.8	81.1	81.3	49.9	109.45	87.61
LC-12	15.60	2,184	2,252	1,832	5,917	1,593	1,420	83.6	83.9	81.1	81.4	54.7	117.85	94.33
LC-13	17.00	2,380	2,464	1,966	6,358	N/A	1,526	83.5	82.2	81	79.8	58.7	—	101.05
LCE-14	18.40	2,576	2,657	2,125	6,875	N/A	1,650	83.5	82.5	81	80	63.5	—	107.77
LCE-15	19.80	2,772	2,850	2,284	7,388	N/A	1,773	83.5	82.6	81	80.2	68.2	—	114.49
LCE-16	21.00	2,940	3,043	2,444	7,908	N/A	1,898	83.5	82.8	81	80.3	73	—	121.21
LCE-17	22.50	3,150	3,236	2,603	8,421	N/A	2,021	83.5	82.9	81	80.4	77.8	—	127.93
LCE-18	24.00	3,360	3,429	2,763	8,938	N/A	2,145	83.5	83.1	81	80.6	82.5	—	134.65
LCE-19	25.00	3,500	3,622	2,922	9,454	N/A	2,269	83.5	83.2	81	80.7	87.3	—	141.37
LCE-20	26.50	3,710	3,815	3,082	9,971	N/A	2,393	83.5	83.3	81	80.8	92.1	—	148.09
LCE-21	28.00	3,920	4,027	3,256	10,533	N/A	2,528	83.6	83.3	81.1	80.8	97.3	—	154.81
LCE-22	29.50	4,130	4,239	3,430	11,096	N/A	2,663	83.6	83.4	81.1	80.9	102.5	—	161.53
LCE-23	31.00	4,340	4,451	3,604	11,658	N/A	2,798	83.7	83.5	81.2	81	107.7	—	168.25
LCE-24	32.50	4,550	4,663	3,777	12,217	N/A	2,932	83.7	83.5	81.2	81	112.8	—	174.97

1 Burner input based on No. 2 fuel oil with a heating value of 140,000 Btu per gallon.

2 Net water ratings based on allowance of 1.15.

3 Net steam ratings based on an allowance for LC-04 to LC-08=1.333, LC-09=1.323, LC-10=1.310, LC-11=1.298, LC-12=1.290, LCE-13 to LCE-24=1.288.

4 Consult factory before selecting a boiler for installation having unusual piping and pickup requirements, such as intermittent system operation, extensive piping systems, etc.

5 Combustion and thermal efficiencies are determined in accordance with BTS 2000 Testing Standard.



PeerlessBoilers.com



Printed on Recycled Paper

PeerlessBoilers.com

CUT-LC R3 (8/19-1C)

Printed in U.S.A.

©2019 PB Heat, LLC. All rights reserved.