

- Navien **Ready-Link-Rack™** system can be used to mount a single or multiple water heater or boiler units that are connected to a cascade system
- **Compatible** with the following Navien models for **INDOOR** use only:  
**NPE-A Series Tankless Water Heaters**  
**NPE-S Series Tankless Water Heaters**  
**NCB-E Series Combination Boilers**  
**NHB Heating Boilers**
- **Recommended** for systems that are located in tight spacing or in areas without enough available wall spacing.
- **Designed** to hold water heater and boiler units as well as common water piping and exhaust venting
- The Navien **Ready-Link-Rack™** includes the following items:

<b>Post Bar 64.4"</b> * Single kit: 2 EA ** Extension kit: 1 EA	<b>Fixed Bar 17.7"</b> * Single kit: 2 EA ** Extension kit: 2 EA	<b>Base Frame 23.8"</b> * Single kit: 2 EA ** Extension kit: 1 EA	<b>Fixed Bracket</b> * Single kit: 10 EA ** Extension kit: 8 EA
<b>Reinforcement Plate</b> * Single kit: 2 EA ** Extension kit: 1 EA	<b>Tapping Screw 5X12 (stainless steel)</b> * Single kit: 44 EA ** Extension kit: 36 EA	<b>M10 Bolt Set (stainless steel)</b> * Single kit: 13 EA ** Extension kit: 8 EA	<b>Installation Guide</b> 1 EA

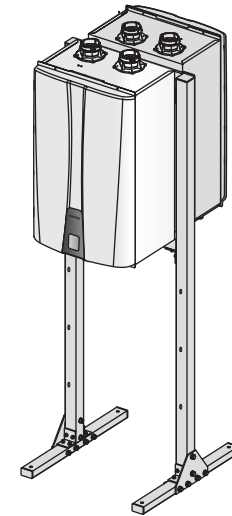

**NEW! Compact Design with  
In-line or Front-to-Back Setup**

- **Dimensions:** see below
- **Weight:** 42.0 lbs (19.0 kg) per BASE Kit, 24.0 lbs (10.9 kg) per ADD-ON Kit
- **Navien Part Number(s):** **GFFM-KDIZUS-001** (BASE for single or 2 units front-to-back)  
**GFFM-KDIZUS-002** (ADD-ON kit to expand system for 3+ units or in-line setup)

### Dimensions

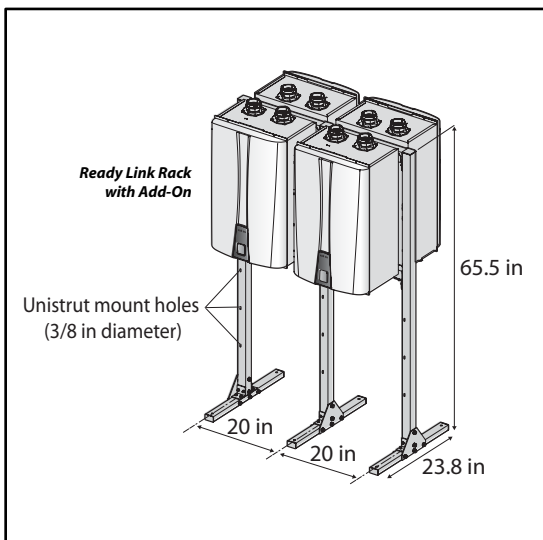

### Installation Examples

