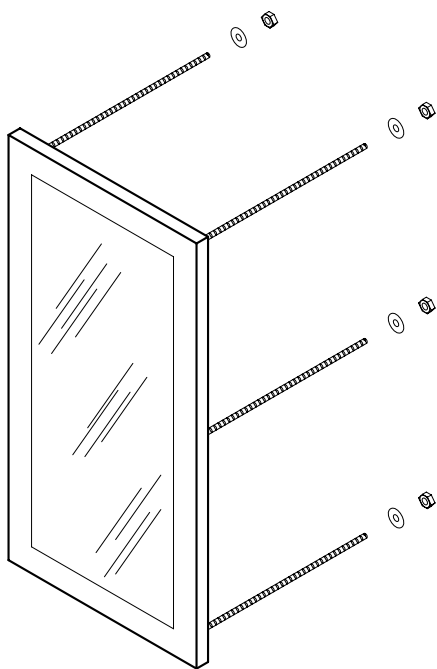

HIGH SECURITY MIRROR - A750

Item: _____

 A750 Mirror

- Chase mounted mirror
 - 12" (305mm) x 16" (406mm).
- Hardware-
 - Plated steel concealed anchor rods and fasteners.

Unit may be pictured with some optional features.

► DESCRIPTION

This Mirror is designed for high security areas with an accessible pipe chase. Frame is fabricated using heavy gauge type 304 stainless steel with a satin finish. Mirror is fabricated using heavy gauge type 304 stainless steel with a polished #8 mirror finish.

► INSTALLATION

An accessible pipe chase is required. Six anchor rods screw into sockets on back of the fixture. Anchor rods pass through the wall and are secured with washers and hex nuts on the chase side of the wall. Installer must provide holes in the wall for anchor rods per the rough-in drawings. The mirror is 12" (305mm) x 16" (406mm).

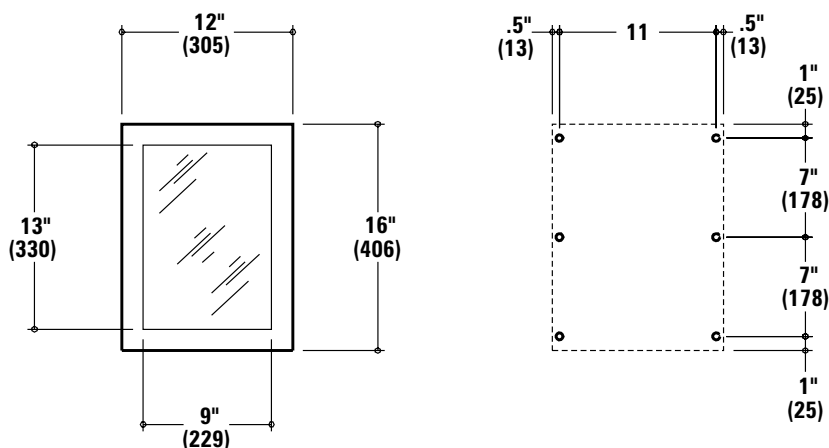

Due to continuous product improvement Metcraft reserves the right to make changes in design and specifications without prior notice. All dimensions should be verified with the factory for current information.

**APPROVED FOR
MANUFACTURING**

 Company: _____ Name: _____
 Signature: _____ Date: _____