

MAAX SUBMITTAL SPECIFICATIONS

Vivez l'expérience

MAAX®

Enjoy the experience

CS 06

MODEL NUMBER 103564

DIMENSIONS: 72" x 42" x 20" Acrylic

Water Capacity: Maximum 67 G Minimum 50 G



STANDARD FEATURES

- Graceful, elegant lines lend a touch of luxury and distinction to this appealing bath. Available in tub only and an array of True Whirlpool Systems with optional back massage, Aeroeffect Air Systems and Combination True Whirlpool and Aeroeffect Air Systems. Options include cable-operated waste and overflow, grab bars, in-line heater, skirt with removable panel, chromotherapy and pillow. Drop-in, alcove or undermount installation.

OPTIONS

- n/a

UNIQUE FEATURES

- n/a

SYSTEMS

DOOR SELECTION

Combine with MAAX's complete shower door offering visit www.maax.com

Project :
Contractor :
MAAX Representative : Tel :
Date :

CERTIFICATIONS

Maax products adhere to one or more of the following certifications:



MAAX SUBMITTAL SPECIFICATIONS

CS 06

MODEL NUMBER 103564

TECHNICAL DRAWINGS

TRUE WHIRLPOOL
SYSTEM

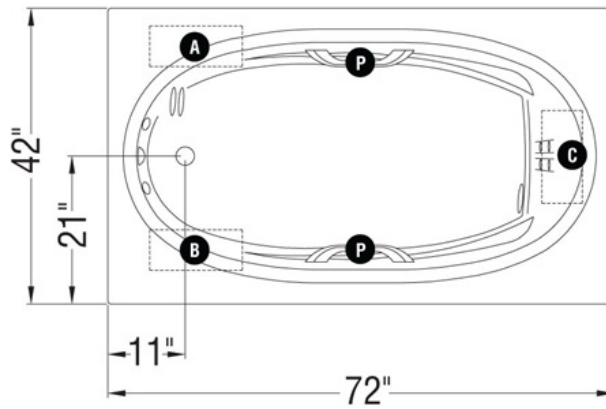

AEROEFFECT
AIR SYSTEM

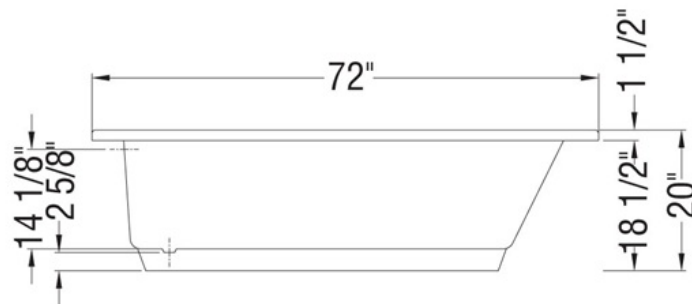
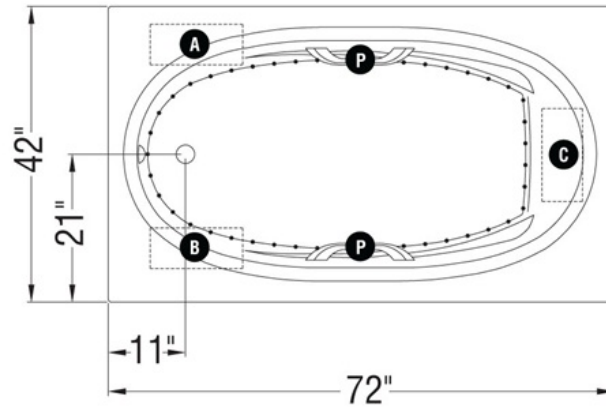

- A** : Indicates pump or blower positioning
- B** : Indicates pump or blower positioning
- C** : Indicates pump or blower positioning
- P** : Indicates optional grab bars positioning
- (○) : Indicates True Whirlpool jets positioning