

**SPECIFICATION:**

JOSAM 60810 SERIES STEEL OIL SEDIMENT SEPARATOR WITH ACID-RESISTING COATING, THREADED CONNECTION, FLAT BOTTOM, VISIBLE DOUBLE WALL TRAP, REMOVABLE SEDIMENT BUCKET, PRIMARY AND SECONDARY SCREENS AND MEDIUM-DUTY CAST IRON GRATE(S).

**OIL SEPARATOR  
OIL SEDIMENT INTERCEPTOR**

SERIES

**60810**

SLOT WIDTH 1/2"

FORMERLY 61850 SERIES

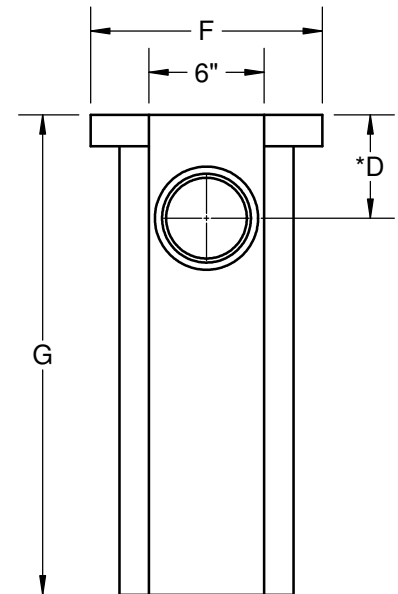
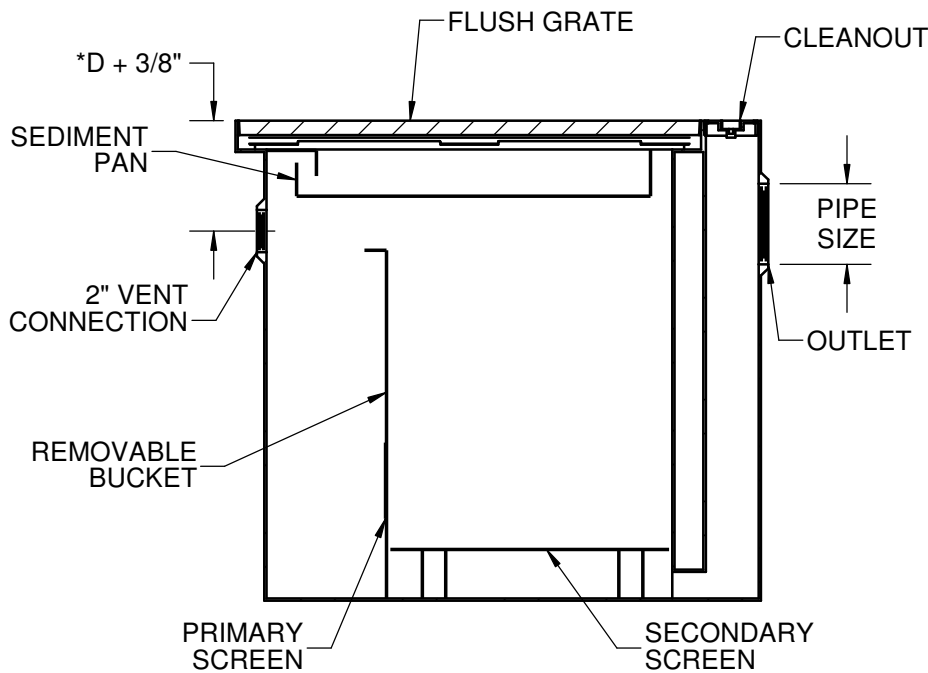
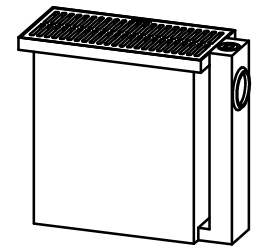
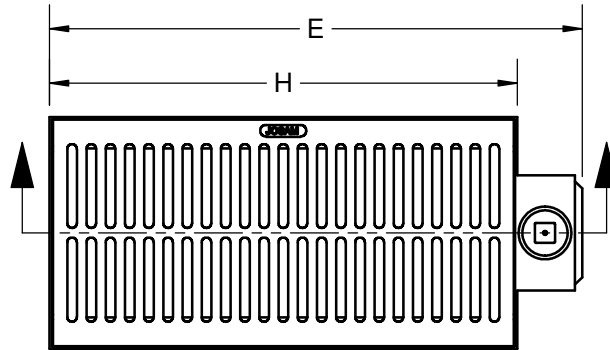

**\*For Custom Extension Height:**

Specify "D" Dimension = \_\_\_\_\_ in

New "G" Dimension = \_\_\_\_\_ in

TYPE NO.	PIPE SIZE	GRATE FREE AREA (SQ. IN.)	NO. OF GRATES	SLUDGE CAP. (LBS.)	D	E	F	G	H
60816	2	54	1	12	5-3/8	17-1/2	12-1/8	15	12-1/8
60817	4	112	1	60	5-3/8	29-7/8	12-1/2	25	24-1/2
60818	4	224	2	100	5-3/8	29-7/8	24-1/2	25	24-1/2
60819	4	336	3	200	5-3/8	41-7/8	24-1/2	35	36-1/2

DATE OF LAST CHANGE: 7/21/14

DIMENSIONS ARE SUBJECT TO MANUFACTURERS TOLERANCES AND CHANGE WITHOUT NOTICE. WE CAN ASSUME NO RESPONSIBILITY FOR USE OF SUPERSEDED OR VOID DATA.

**JOSAM COMPANY**  
MICHIGAN CITY, INDIANA

NOTES