

30000 SERIES	BODY ASSEMBLY												
<p style="text-align: center;">APPLICATION</p> <p>For use with all adjustable strainers. Wide flange anchors drain body in concrete and works in conjunction with the clamp collar to redirect waste through the collar's weepholes if seepage occurs around the strainer. The WEJLOC® clamp provides a non-puncturing positive bond of the waterproofing membrane to the drain body for applications where floors with standing water are to be sealed off from areas below. The collar is also invertible for extra vertical strainer adjustment to meet finished floor level.</p>	<p>THIS DRAIN BODY CAN BE USED WITH ALL STRAINERS AND ACCESSORIES IN THE STRAINER SECTION.</p>												
<p style="text-align: center;">SPECIFICATION</p> <p>JOSAM 30000 Series coated cast iron Floor Drain, two-piece body with double drainage flange and 1/2" primer tap with plug, bottom outlet, WEJLOC® invertible non-puncturing flashing collar with weepholes, threaded to receive a JOSAM adjustable strainer.</p>													
<p style="text-align: center;">Available Options</p> <table style="width:100%; border: none;"> <tr> <td style="width: 30%; vertical-align: top;"> <ul style="list-style-type: none"> ▼ -PD Prison Drain ▼ -ST Shallow Trap ▼ -TSO Threaded Side Outlet -ARE Acid-Resisting Epoxy -49 3/4" Primer Tap 1/2" Primer Tap (Std.) </td> <td style="width: 30%; vertical-align: top;"> <ul style="list-style-type: none"> -91 Rough Bronze Body -92 Galvanized Cast Iron Parts </td> <td style="width: 40%; vertical-align: top;"> <p style="text-align: center;">OUTLETS:</p> <ul style="list-style-type: none"> -T Threaded Outlet -X Inside Caulk Outlet -Y Hub Outlet with Gasket -Z No-Hub Outlet </td> </tr> </table>		<ul style="list-style-type: none"> ▼ -PD Prison Drain ▼ -ST Shallow Trap ▼ -TSO Threaded Side Outlet -ARE Acid-Resisting Epoxy -49 3/4" Primer Tap 1/2" Primer Tap (Std.) 	<ul style="list-style-type: none"> -91 Rough Bronze Body -92 Galvanized Cast Iron Parts 	<p style="text-align: center;">OUTLETS:</p> <ul style="list-style-type: none"> -T Threaded Outlet -X Inside Caulk Outlet -Y Hub Outlet with Gasket -Z No-Hub Outlet 									
<ul style="list-style-type: none"> ▼ -PD Prison Drain ▼ -ST Shallow Trap ▼ -TSO Threaded Side Outlet -ARE Acid-Resisting Epoxy -49 3/4" Primer Tap 1/2" Primer Tap (Std.) 	<ul style="list-style-type: none"> -91 Rough Bronze Body -92 Galvanized Cast Iron Parts 	<p style="text-align: center;">OUTLETS:</p> <ul style="list-style-type: none"> -T Threaded Outlet -X Inside Caulk Outlet -Y Hub Outlet with Gasket -Z No-Hub Outlet 											
<p style="text-align: center;">FOR OUTLET TYPE SPECIFY -T, -X, -Y or -Z</p> <table border="1" style="width:100%; border-collapse: collapse;"> <thead> <tr> <th style="width: 30%;">TYPE NO.</th> <th style="width: 30%;">PIPE SIZE</th> <th style="width: 40%;">LBS.</th> </tr> </thead> <tbody> <tr> <td>30002</td> <td>2</td> <td>11</td> </tr> <tr> <td>30003</td> <td>3</td> <td>13</td> </tr> <tr> <td>30004</td> <td>4</td> <td>13</td> </tr> </tbody> </table>		TYPE NO.	PIPE SIZE	LBS.	30002	2	11	30003	3	13	30004	4	13
TYPE NO.	PIPE SIZE	LBS.											
30002	2	11											
30003	3	13											
30004	4	13											

30000-PD SERIES	SECURITY BODY ASSEMBLY FOR PRISONS									
<p style="text-align: center;">APPLICATION</p> <p>For use with all adjustable strainers with security screws. The integral trap wall is designed to restrict concealment of contraband. The side outlet allows for installation of drain line within pre-cast prison cells.</p>	<p>THIS DRAIN BODY CAN BE USED WITH ALL STRAINERS AND ACCESSORIES IN THE STRAINER SECTION.</p>									
<p style="text-align: center;">SPECIFICATION</p> <p>JOSAM 30000-PD Series galvanized steel security Floor Drain with flashing flange, threaded side outlet, integral trap wall. Threaded to receive any JOSAM adjustable strainer furnished with security screws.</p>										
<p style="text-align: center;">Available Options</p> <ul style="list-style-type: none"> -50 1/2" Primer Tap -92 Galvanized Cast Iron Parts -C Bolted Flashing Clamp Device <p>OUTLET:</p> <ul style="list-style-type: none"> -T Threaded Outlet 										
<p style="text-align: center;">FOR OUTLET TYPE SPECIFY -T</p> <table border="1" style="width:100%; border-collapse: collapse;"> <thead> <tr> <th style="width: 30%;">TYPE NO.</th> <th style="width: 30%;">PIPE SIZE</th> <th style="width: 40%;">LBS.</th> </tr> </thead> <tbody> <tr> <td>30002-PD</td> <td>2</td> <td>15</td> </tr> <tr> <td>30003-PD</td> <td>3</td> <td>15</td> </tr> </tbody> </table>		TYPE NO.	PIPE SIZE	LBS.	30002-PD	2	15	30003-PD	3	15
TYPE NO.	PIPE SIZE	LBS.								
30002-PD	2	15								
30003-PD	3	15								

FLOOR DRAINS

A SERIES ROUND NIKALOY SUPER-FLO® STRAINER

APPLICATION

For use in finished areas with pedestrian traffic such as toilet and shower rooms.

Available Options

- SS Stainless Steel, 5A, 6A, 7A, 8A
- 2 Satin Finish Bronze
- 80 Perforated Stainless Steel Basket
- CP Chrome Plated, 5A, 6A
- J Backwater Valve
- VP Secured Grate, Vandal-Proof Screws

TYPE NO.	A	B	C	D	FREE AREA	LBS.
5A	5	1-15/16	1-1/8	4-5/8	7.8	2
6A	6	2-1/4	15/16	5-1/4	11.0	3
7A	7	2-11/16	1-1/2	6-7/16	13.2	4
8A	8	2-1/2	7/8	7-1/8	16.2	5
9A•	9	2-1/4	1	8-1/8	21.1	7
10A•	10	2-1/4	1-1/8	9	28.0	9

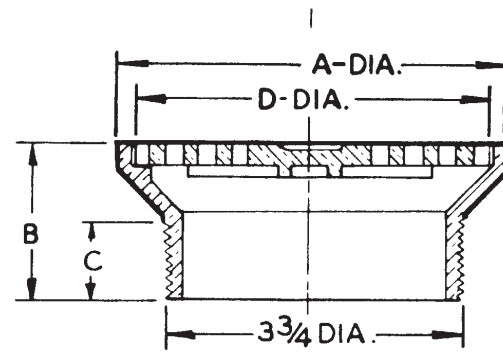

•Not SUPER-FLO® Design

AD SERIES ROUND NIKALOY STRAINER with Clamp Device

APPLICATION

For use in finished areas with pedestrian traffic such as supermarkets or kitchens.

Available Options

- 2 Satin Bronze Top
- VP Secured Grate, Vandal-Proof Screws

TYPE NO.	FREE AREA	LBS.
6AD	10.4	4

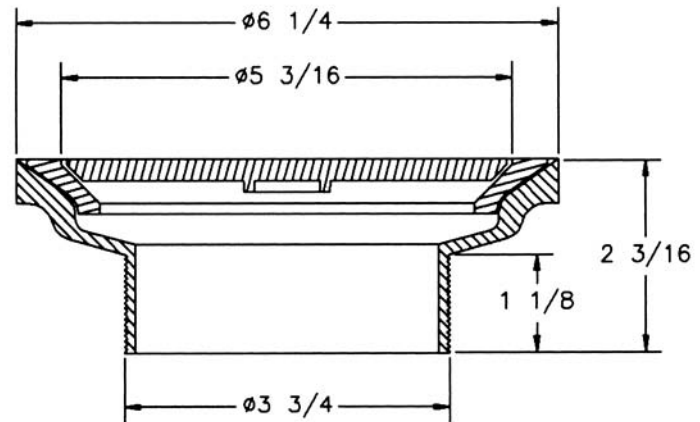

AF SERIES ROUND NIKALOY STRAINER with Tile Flange

APPLICATION

For use in areas where a vinyl tile, liquid or trowel applied floor covering is to be adhered to the strainer flange and pedestrian traffic is expected.

Available Options

- 2 Satin Finish Bronze
- 80 Perforated Stainless Steel Basket
- J Backwater Valve
- VP Secured Grate, Vandal-Proof Screws

TYPE NO.	FREE AREA	LBS.
6AF	10.4	5

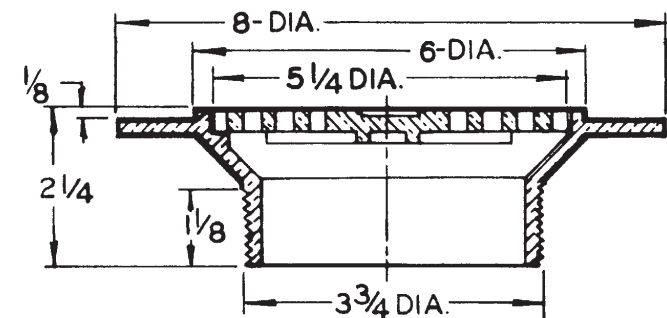

FLOOR DRAINS