

Brita® Hydration Station® with Lifecycle Control

SURFACE-MOUNT

MODEL **2000SMS**

FEATURES & BENEFITS

SENSOR OPERATED

Electric sensor allows for touch-free hygienic operation, eliminating the need for manual activation under a number of circumstances.

QUALITY CONTROL

The Brita® Hydration Station® is pre-built and fully water and pressure tested to ensure no leaks and proper function for reduced installation time and added peace of mind.

DURABLE FINISH

#4 satin stainless steel back panel can be easily cleaned and maintained while also resisting corrosion.

SERVICING & SECURITY

Durable ABS plastic front panel allows simple access to internal components. 30-second time-out prevents unwanted use. Hidden lock and hinges discourage vandals.

ADVANCED FILTRATION

2,500 gallon (9464 L) capacity, electronic lifecycle control filter cartridge will shut off water flow when capacity is reached to ensure great-tasting water with every activation. Filter replacement indicator light will flash yellow when filter life is at 10% and will flash red when replacement is necessary. Preparing to replace filter is important when the filter light flashes yellow.

EXTENDED WARRANTY

Product carries an extended 3-year warranty.

OPTIONS

- ❑ Filter: Brita® Model 6429 is the replacement filter for the BRITA® HYDRATION STATION® Model 2000SMS
- ❑ Drain kit: Model 6470 to hard plumb unit to waste line.

SPECIFICATIONS

Model 2000SMS BRITA® HYDRATION STATION® is a wall-mounted bottle or cup filling station constructed of durable ABS plastic and 16-gauge, Type 304 Stainless Steel with a satin finish. It features an electric sensor allowing for touch-free hygienic operation, laminar flow to prevent splashing, and a .5 gpm (1.3 L) flow rate for quick fill-up. 2,500 gallon (9464 L) carbon block filter reduces chlorine (taste and odor) and lead, and removes 99.99% of cysts. Hidden lock and hinges on ABS plastic front panel allows access to internal components. The mounting consists of heavy-gauge galvanized steel mounting bracket and hardware, and an adjustable, external electrical cord with maximum length of 6'. 110 volt, 60Hz, and .1 amp draw when in use. A removable water catch basin is provided; this may be converted to a hard-plumbed drain with a retrofit kit. External dimensions: 15"W x 6.94"D x 30.25"H.



APPLICATIONS

The surface-mount BRITA® HYDRATION STATION® is perfect for mounting on block or solid walls which cannot be cut into as an alternative to the recessed-mount BRITA® HYDRATION STATION®. The surface mount unit does not require a drain trap and has an integrated drain pan. Therefore, it can be mounted in any location where there is reasonable access to a water line. Specifically, this unit is ideal for office buildings, universities, fitness centers, and more.

Model 2000SMS meets the Americans with Disabilities Act when mounted at the correct height, and cane bump bar is properly installed (see Operators Manual). HAWS® manufactures drinking fountains and electric water coolers to be lead-free by all known definitions including NSF/ANSI Standard 61, Section 9, NSF/ANSI Standards 42 & 53, NSF/ANSI 372, and CSA Standard B483.1. Product is compliant to California Health and Safety Code 116875 (AB1953), California Proposition 65 and the Federal Safe Drinking Water Act. Model 2000SMS is certified to the standard for Water Treatment Appliances (UL 979).



By HAWS CORPORATION® • www.BritaHydrationStation.com • Call Haws at 1.888.909.4297

The BRITA trademark and logo are registered trademarks of Brita LP and are used under license by Haws Corporation. All rights reserved.

REV. 06/14

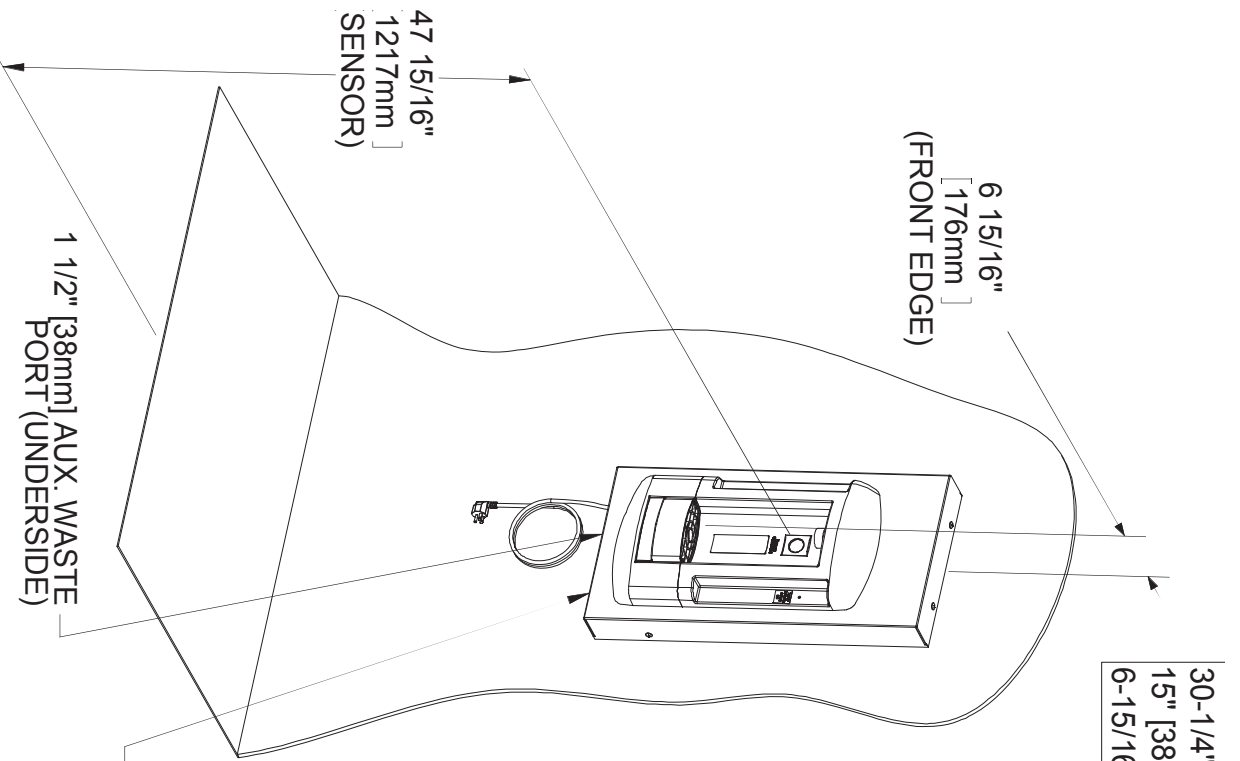

FRONT VIEW

1 1/2" [38mm] AUX. WASTE PORT (UNDERSIDE)

1/2" [13mm] SUPPLY PORT W/ 3/8" [10mm] I.D. GROMMET (UNDERSIDE)

47 15/16" [1217mm] SENSOR

6 15/16" [176mm] (FRONT EDGE)

30-1/4" [768] HEIGHT
15" [381] WIDTH
6-15/16" [176] DEPTH

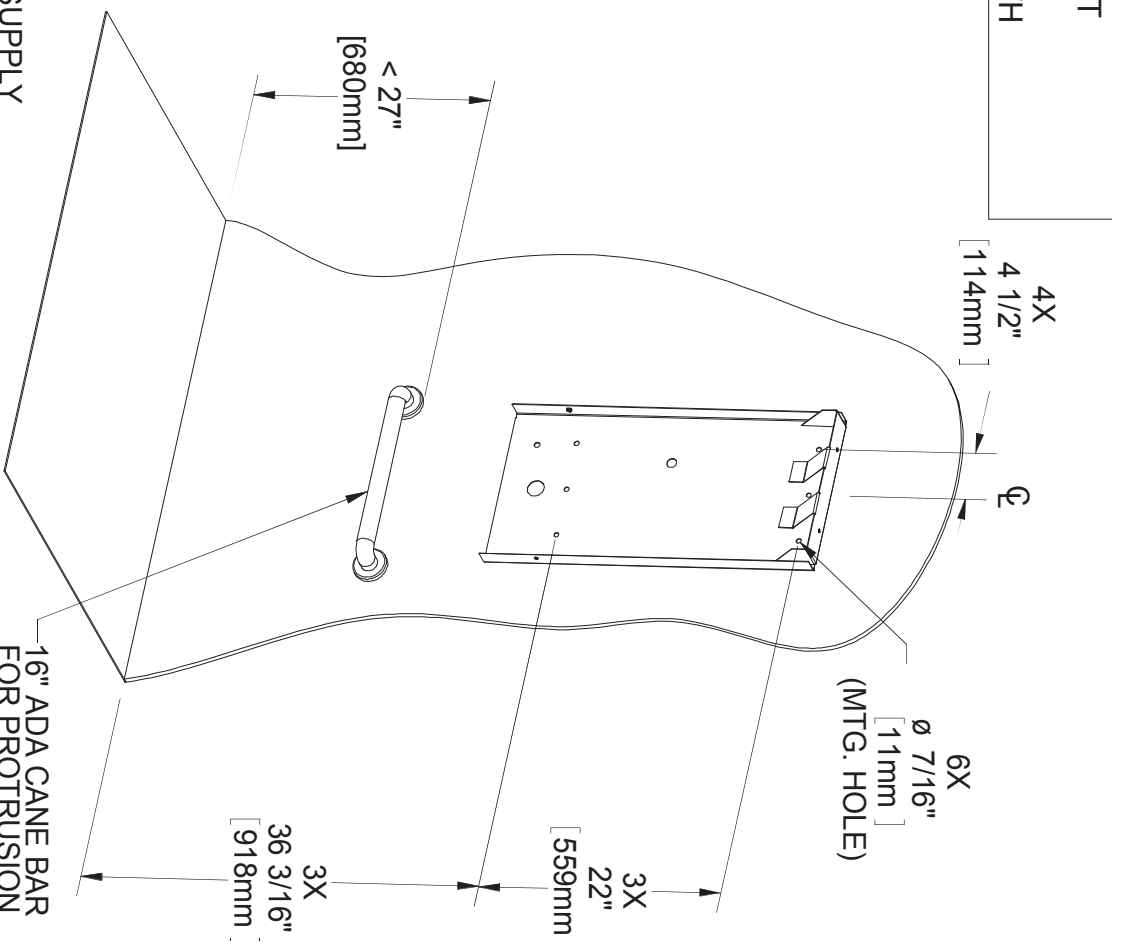

MOUNTING BRACKET VIEW

16" ADA CANE BAR FOR PROTRUSION LIMIT, IF REQUIRED (BY OTHERS)

< 27" [680mm]

4X 4 1/2" [114mm]

6X Ø 7/16" [11mm] (MTG. HOLE)

3X 22" [559mm]

3X 36 3/16" [918mm]



1455 KLEPPE LANE
SPARKS, NEVADA 89431
(775) 358-4712 FAX (759) 358-7424
E-MAIL: HAWS@HAWS.CO.COM
WEBSITE: WWW.HAWS.CO.COM

ENNO: 4890	REVISED PER BY: J. LINN	MODEL(S): 2000SMS	PART NUMBER: 0002077011
DATE: 2/12	CHKD: []	BRITA HYDRATION STATION	DRAWING NO: 16179A
APPROVED: []	DATE: []	SCALE: N/A	SIZE: A
		DRAWING TYPE: INSTALLATION	SHEET: 1 OF 2