

FEATURES & BENEFITS

UNIVERSAL MOUNTING

This unit is perfect as a stand-alone bottle filling station, or easily located over virtually any wall mounted drinking fountain or water cooler with its quick mount wall frame. The unit connects to the fountain's water line, and naturally drains into the waste so there is no need for new water or drain lines.

CONSTRUCTION

Medium grey ABS plastic construction aesthetically blends in with stainless steel drinking fountain basins, and easily resists stains and fingerprints.

USEABLE FOOTPRINT

With its narrow width dimensions of only 8-1/4" (21 cm), this bottle filler can be mounted above almost any drinking fountain with ease. This compact size does not take away from its large bottle filling area accommodating bottle sizes up to 10" (25.4 cm) high.

REVERSIBLE DRAIN TRAY

Patent pending flexible design allows for outward drain to be reversed inward allowing drain water to be connected to waste inside of wall.

PUSH BUTTON

With its patented stainless steel, push-button activated valve assembly which allows for front access stream adjustment as well as cartridge and strainer access, this bottle filler offers 100% lead free waterways. The valve works at an operating pressure range of 30 to 90 psi (2.1 to 6.2 bar).



SPECIFICATIONS

Model 1900 wall mounted bottle filler shall include 100% lead-free waterways, push-button operated stainless steel valve with front-accessible cartridge and flow adjustment, patent pending reversible waste attachment for over-fountain or in-wall waste drain, medium grey ABS plastic construction, and easy to use mounting frame with easy to follow mounting instructions.

OPTIONS

- Remote Chiller: Model HCR8, 8 gph (30.3 L) remote water chiller provides instantaneous cooling to meet a continuous demand for chilled water.

To see all options for this model, visit www.hawsco.com

APPLICATIONS

This type of wall mounted bottle filler may be placed in settings such as: schools and other locations in and around office buildings with existing fountain installations where the temperature remains above freezing. Model meets all current Federal Regulations for the disabled including those in the Americans with Disabilities Act. Haws® manufactures drinking fountains and electric water coolers to be lead-free by all known definitions including NSF/ANSI 61, Section 9, NSF/ANSI 372, California Proposition 65, and the Federal Safe Drinking Water Act. Product is compliant to California Health and Safety Code 116875 (AB 1953-2006).

NOTES:

1. HOLD ROUGH-IN DIMENSIONS $\pm 1/4"$ (6.4mm).
2. WHEN INSTALLING THIS UNIT, LOCAL, STATE, OR FEDERAL CODES SHOULD BE ADHERED TO. FOR INSTALLATION HEIGHTS OTHER THAN SHOWN, DIMENSIONS MARKED (*) MUST BE ADJUSTED ACCORDINGLY. INSTALL A TRAP IN THE WASTE LINE AND A SCREWDRIVER STOP IN THE SUPPLY LINE IF REQUIRED.
- 3 REFER TO 5874SS OPERATION & MAINTENANCE MANUAL FOR PUSH BUTTON AND VALVE INSTALLATION & MAINTENANCE INSTRUCTIONS.
- 4 BOTTLE FILLER IS SHOWN INSTALLED AT ADA MAXIMUM OBSTRUCTED FORWARD REACH HEIGHT. FOR ADA OBSTRUCTED SIDE REACH COMPLIANCE, BOTTLE FILLER MUST BE LOWERED 2". ADA COMPLIANCE DEPENDS ON OVERALL SIZE OF WATER COOLER OR DRINKING FOUNTAIN (SEE SHEETS 3 & 4).

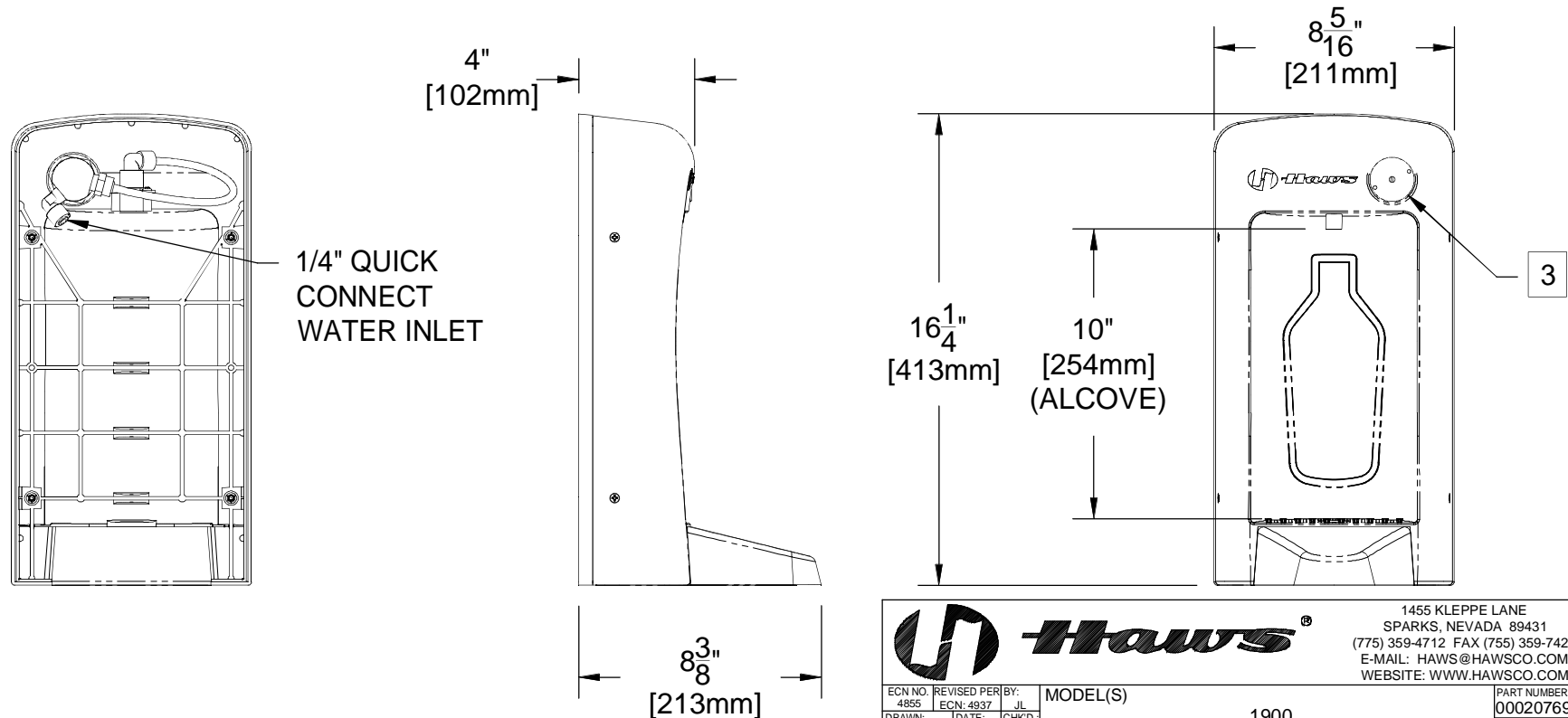

		1455 KLEPPE LANE SPARKS, NEVADA 89431 (775) 359-4712 FAX (755) 359-7424 E-MAIL: HAWS@HAWS.CO.COM WEBSITE: WWW.HAWS.CO.COM	
		ECN NO. 4855 DRAWN: JL APPROVED:	REVISED PER: JL ECN: 4937 DATE: 2/10/14
SCALE: N/A		DRAWING TYPE: INSTALLATION	
SIZE: A		SHEET 1 OF 4	

DRAIN SETUP

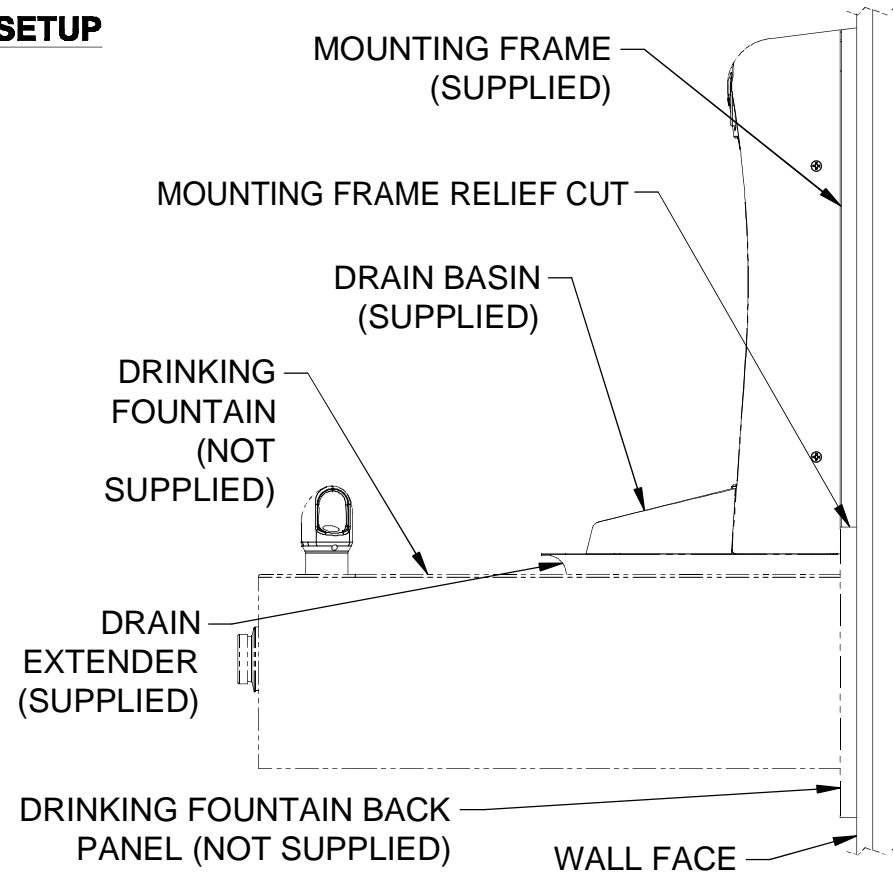
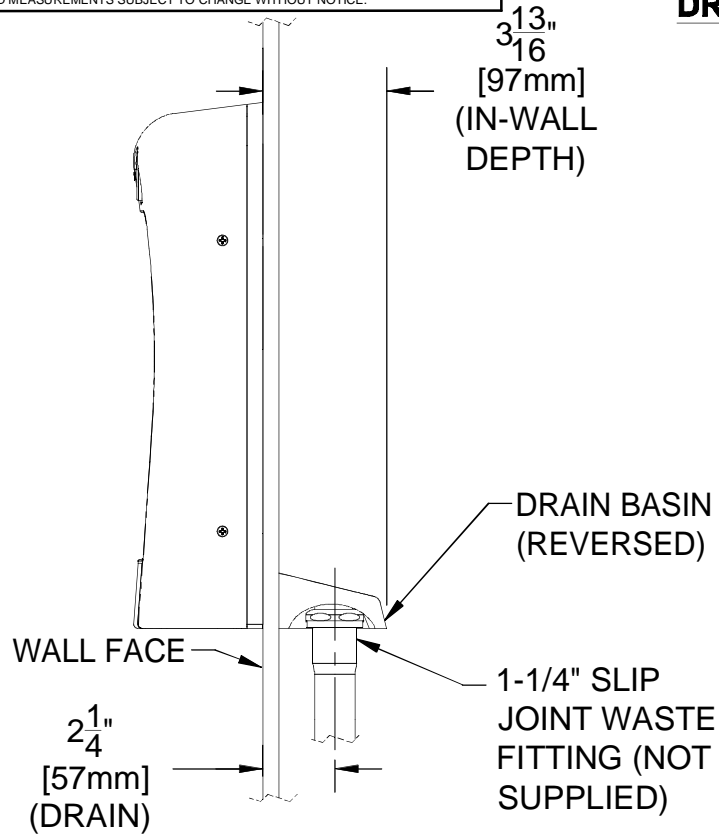

DRAIN SEAL DETAIL

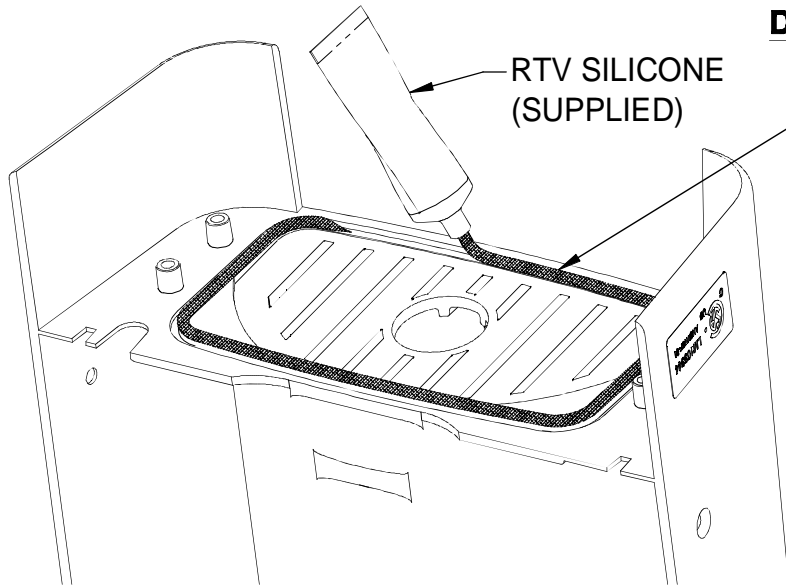

RUN A 1/8"-3/16" DIAMETER BEAD OF RTV RIGHT ALONGSIDE THE GROOVE, BUT NOT IN THE GROOVE. CHECK THE RTV BEAD FOR THIN SECTIONS, GAPS, OR AREAS WHERE THE BEAD DOES NOT TOUCH THE PLASTIC - FILL THESE IN WITH RTV.

			1455 KLEPPE LANE SPARKS, NEVADA 89431 (775) 359-4712 FAX (755) 359-7424 E-MAIL: HAWS@HAWSO.COM WEBSITE: WWW.HAWSO.COM		
ECN NO. 4855	REVISED PER ECN: 4937	BY: JL	MODEL(S)	1900	PART NUMBER 0002076963.D
DRAWN: JL	DATE: 2/10/14	CHKD: JL	BOTTLE FILLER, EWC RETROFIT		DRAWING NO. 16317A
APPROVED:	DATE:		SCALE: N/A	DRAWING TYPE: INSTALLATION	REV 2
			SIZE: A		SHEET 2 OF 4

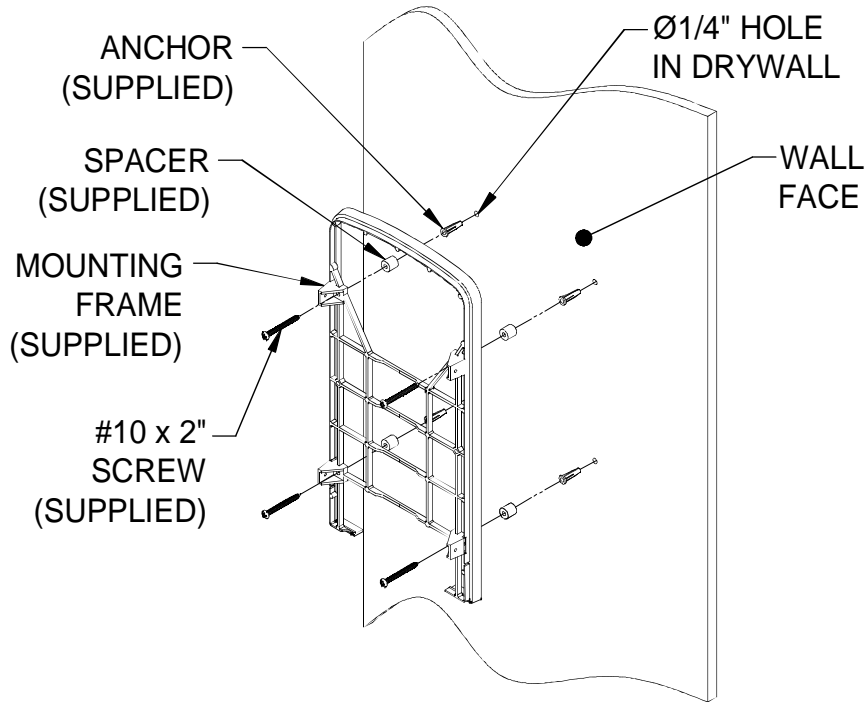

MOUNTING FASTENER DETAIL

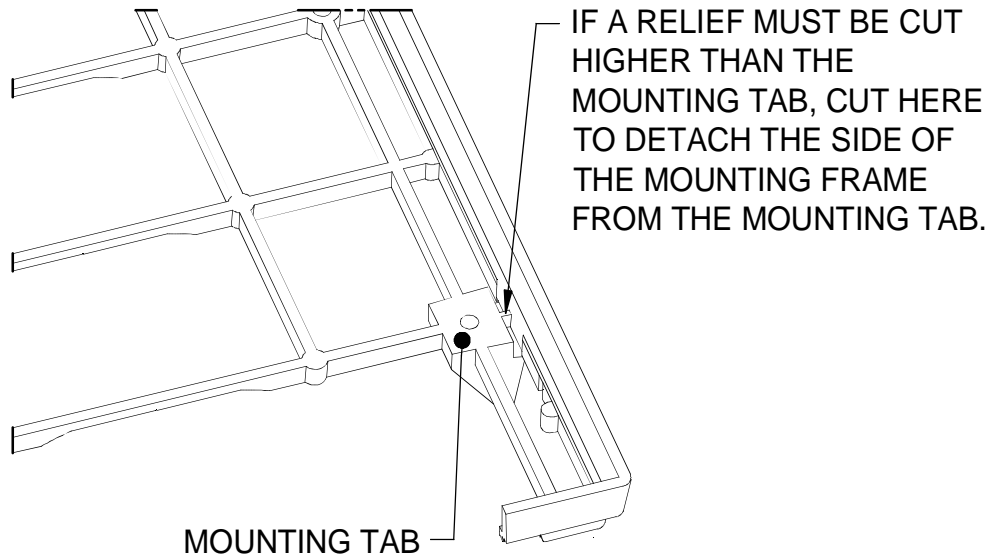

MOUNTING TAB

CUTTING THE MOUNTING FRAME RELIEF

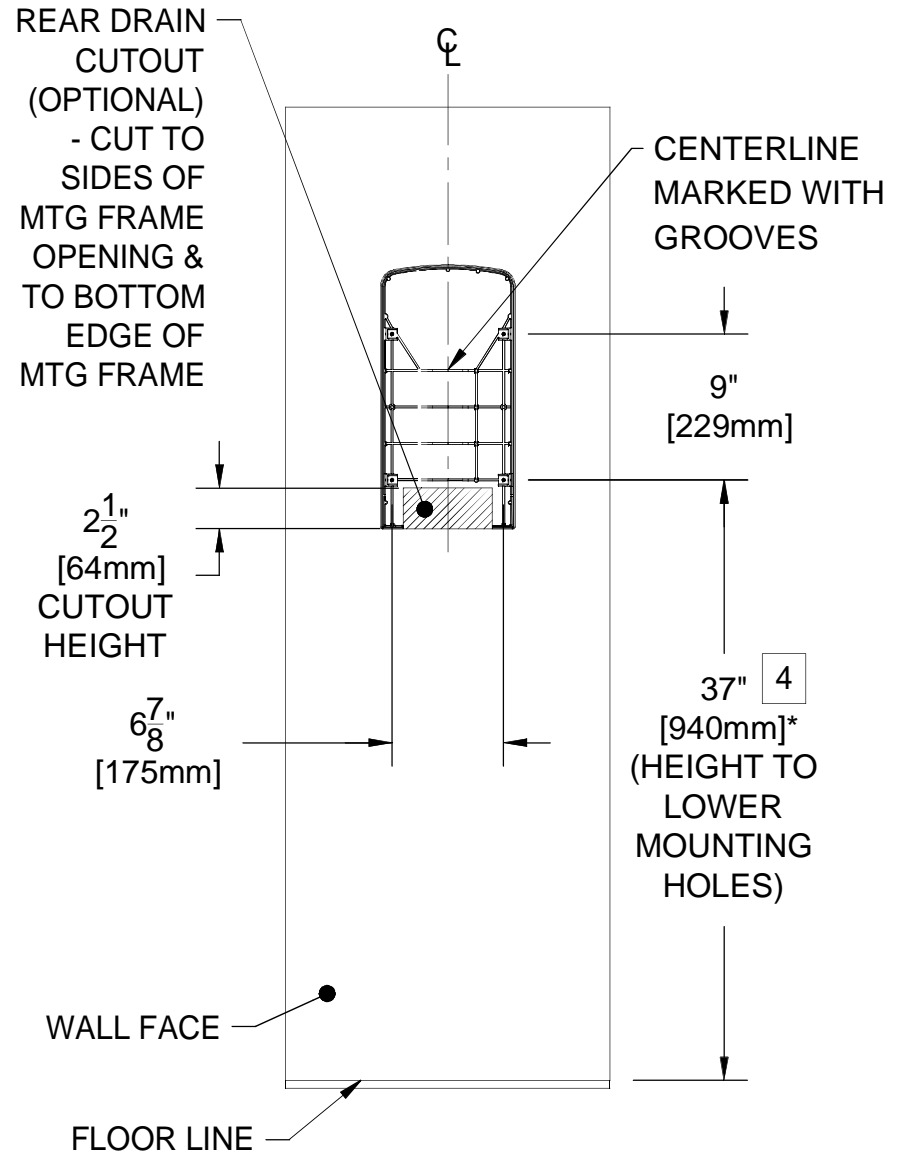

MOUNTING FRAME & OPTIONAL REAR DRAIN CUTOUT DETAILS

		1455 KLEPPE LANE SPARKS, NEVADA 89431 (775) 359-4712 FAX (755) 359-7424 E-MAIL: HAWS@HAWS.CO.COM WEBSITE: WWW.HAWS.CO.COM	
		ECN NO. 4855 DRAWN: JL APPROVED:	REVISED PER BY: JL ECN: 4937 DATE: 2/10/14 DATE:
SCALE: N/A		DRAWING TYPE: INSTALLATION	SIZE: A SHEET 3 OF 4

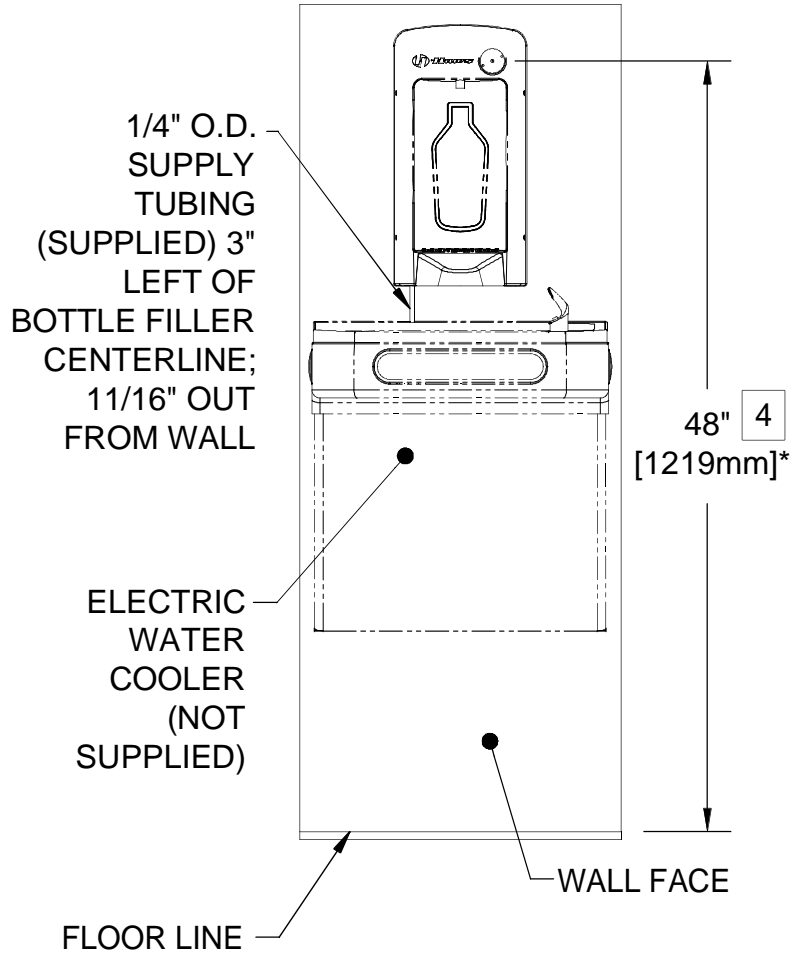

TYPICAL WATER COOLER INSTALLATION

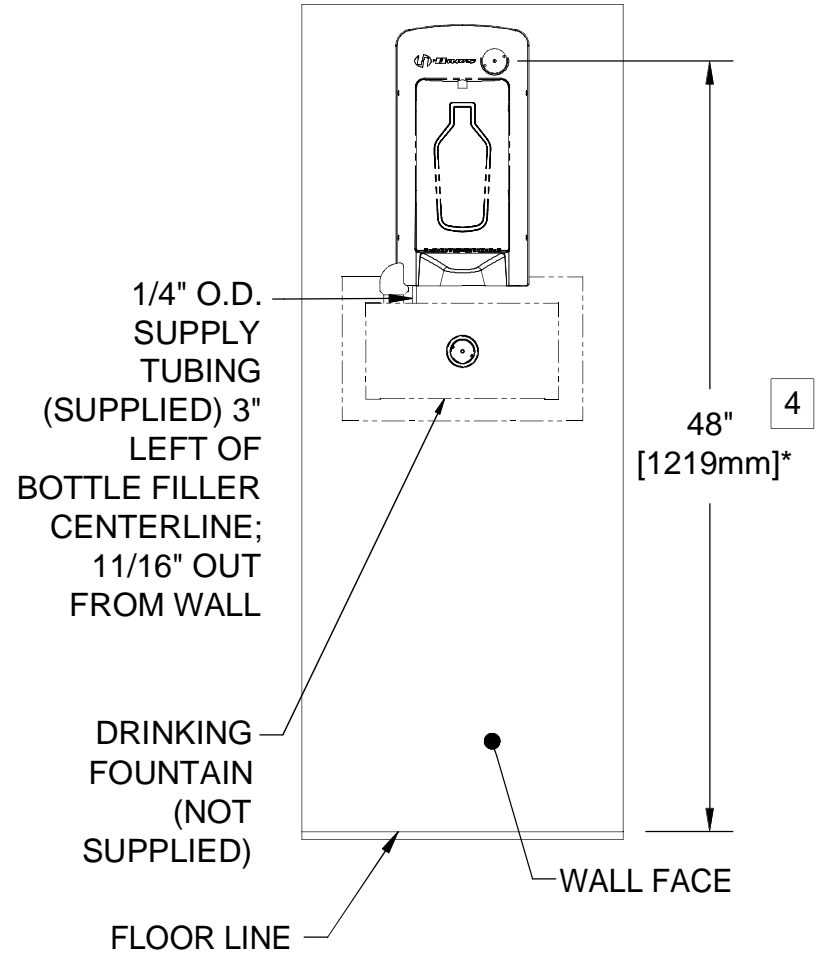

TYPICAL DRINKING FOUNTAIN INSTALLATION

		1455 KLEPPE LANE SPARKS, NEVADA 89431 (775) 359-4712 FAX (755) 359-7424 E-MAIL: HAWS@HAWS.CO.COM WEBSITE: WWW.HAWS.CO.COM	
		ECN NO. 4855 DRAWN: JL APPROVED: JL	REVISER PER BY: JL ECN: 4937 DATE: 2/10/14 CHKD.:
SCALE: N/A		DRAWING TYPE: INSTALLATION	
SIZE: A		SHEET 4 OF 4	