



Air Conditioning & Heating

GPH16M

COOLING CAPACITY: 24,000 - 58,000 BTU/H

HEATING CAPACITY: 22,800 - 55,000 BTU/H

HIGH-EFFICIENCY PACKAGED HEAT PUMP 2 TO 5 TONS UP TO 16 SEER / 8.2 HSPF



Contents

Nomenclature.....	2
Product Specifications.....	3
Expanded Cooling Data	4
Airflow Data	16
Expanded Heating Data.....	16
Auxiliary Heat Data	20
Heat Kit Electrical Specs.....	23
Dipswitch Settings	24
Dimensions	25
Wiring Diagrams	28
Accessories	30

Standard Features

- High-efficiency two-stage scroll compressor with internal relief valve
- Two-stage heating and cooling
- Multi-Speed ECM indoor blower motor
- Copper tube/aluminum fin condenser coils
- All-aluminum evaporator coil on 2- to 4-ton units
- Aluminum-copper evaporator coil on 5-ton units
- Liquid-line filter drier
- Convertible airflow: horizontal or downflow
- Totally enclosed, permanently lubricated condenser fan motor
- Electric heat kit available as a field-installed option
- OTHPPKG (Outdoor Thermostat Kit) when used on 2.0 and 2.5 ton allow the unit to achieve 8.2 HSPF

Cabinet Features

- Heavy-gauge galvanized-steel cabinet with attractive two-tone Architectural Gray powder-paint finish
- Aluminum foil-facing internal insulation reinforced with fiberglass scrim
- Fully insulated air-handling compartment with convenient access panels
- Louvered condenser coil protection
- Meets cabinet air leakage requirements when tested in accordance with ASHRAE standard 193

10 YEAR LIMITED WARRANTY*





COMPANY WITH QUALITY SYSTEM CERTIFIED BY DNV GL = ISO 9001 =

COMPANY WITH ENVIRONMENTAL SYSTEM CERTIFIED BY DNV GL = ISO 14001 =



* Complete warranty details available from your local dealer or at www.goodmanmfg.com. To receive the 10-Year Parts Limited Warranty, online registration must be completed within 60 days of installation. Online registration not required in California or Québec.

	G	P	H	16	36	M	4	1	*	*	
	1	2	3	4,5	6,7	8	9	10	11	12	
Brand	G Goodman® brand									Engineering	
										Minor Revision	
Product Category	P Packaged Unit									Engineering	
										Major Revision	
Type	H Heat Pump C Air Conditioner									Voltage Designator	
										1 208-230/1/60 3 208-230/3/60	
Efficiency	14 14 SEER 16 16 SEER 15 15 SEER									Refrigerant	
										4 R-410A	
Nominal Capacity	24 2 Tons 36 3 Tons 48 4 Tons 30 2½ tons 42 3½ Tons 60 5 Tons									Configuration	
										H Horizontal M Multi-position	

	GPH16 24M41A*	GPH1624M41 A*+OTHPPKG	GPH16 30M41A*	GPH1630M41 A*+OTHPPKG	GPH16 36M41A*	GPH16 42M41A*	GPH16 48M41A*	GPH16 60M41A*
COOLING CAPACITY								
Total BTU/h	24,000	24,000	29,000	29,000	33,600	41,000	47,000	58,000
Sensible BTU/h	18,200	18,200	22,000	22,000	25,200	30,000	35,800	44,000
SEER / EER	16.0/ 12.5	16.0/ 12.5	15.5/ 12.0	15.5/ 12.0	16.0/ 12.0	16.0/ 12.0	16.0/ 12.0	16.0/ 12.0
Decibels	76	76	76	76	76	78	78	78
AHRI #s	8143312	10061984	8143313	10061985	8143314	8143315	8143316	9134480
HEATING CAPACITY								
BTU/h (47°F)	22,800	22,800	28,400	28,400	33,600	38,000	45,500	55,000
C.O.P (47°F)	3.6	3.6	3.5	3.5	3.6	3.6	3.7	3.8
BTU/h (17°F)	12,500	12,500	16,600	16,200	19,400	21,600	27,000	30,000
C.O.P (17°F)	2.3	2.3	2.4	2.4	2.4	2.3	2.4	2.4
HSPF	8.0	8.2	8.0	8.2	8.2	8.2	8.2	8.2
EVAPORATOR MOTOR								
Type	EEM	EEM	EEM	EEM	EEM	EEM	EEM	EEM
Wheel (D x W)	10 x 9	10 x 9	10 x 9	10 x 9	10 x 9	10 x 9	10 x 9	11x 10
Nominal Cooling CFM	850	850	1,050	1,050	1,200	1,300	1,600	2,000
FLA	4.3	4.3	4.3	4.3	4.3	5.8	5.8	6.9
No. of Speeds	5	5	5	5	5	5	5	5
Horsepower - RPM	½ -1,050	½ -1,050	½ -1,050	½ -1,050	½ -1,050	¾ - 1,050	¾ - 1,050	1 - 1,050
EVAPORATOR COIL								
Face Area (ft²)	4.5	4.5	4.5	4.5	4.5	6.2	6.2	8.9
Rows Deep/ Fin per Inch	4/ 14	4/ 14	4/ 14	4/ 14	4/ 14	4/ 14	4/ 14	4/ 16
Expansion Device	TXV	TXV	TXV	TXV	TXV	TXV	TXV	TXV
Drain Size (NPT)	¾"	¾"	¾"	¾"	¾"	¾"	¾"	¾"
R-410A Refrigerant Charge (oz.)	137	137	137	137	137	170	170	240
CONDENSER FAN / COIL								
Horsepower - RPM	¼ - 850	¼ - 850	¼ - 850	¼ - 850	¼ - 850	¼ - 1,075	¼ - 1,075	1/3 - 1,090
FLA/LRA	1.5/ 3.0	1.5/ 3.0	1.5/ 3.0	1.5/ 3.0	1.5/ 3.0	1.4 / 2.9	1.4 / 2.9	2/ 4.4
Fan Diameter / # Fan Blades	22 / 3	22 / 3	22 / 3	22 / 3	22 / 3	22 / 3	22 / 3	22 / 4
Expansion Device	TXV	TXV	TXV	TXV	TXV	TXV	TXV	TXV
Face Area (ft²)	15.5	15.5	15.5	15.5	15.5	19.4	19.4	19
Rows Deep/ Fin per Inch	2 / 16	2 / 16	2 / 16	2 / 16	2 / 16	2 / 16	2 / 16	2 / 20
COMPRESSOR								
Quantity	1	1	1	1	1	1	1	1
Type	Scroll	Scroll	Scroll	Scroll	Scroll	Scroll	Scroll	Scroll
Stage	Two	Two	Two	Two	Two	Two	Two	Two
ELECTRICAL DATA								
Voltage/ Phase/ Hz	208-230/ 1	208-230/ 1	208-230/ 1	208-230/ 1	208-230/ 1	208-230/ 1	208-230/ 1	208-230/ 1
Compressor RLA/ LRA	11.7 / 58.3	11.7 / 58.3	13.1 / 73	13.1 / 73	15.3 / 83	17.9 / 96	21.2 / 104	26.9/ 152.9
Indoor Blower FLA	4.3	4.3	4.3	4.3	4.3	5.8	5.8	6.9
Total Unit Amps	17.5	17.5	18.9	18.9	21.1	25.1	28.4	35.8
Min. Circuit Ampacity ¹	20.4	20.4	22.2	22.2	24.9	29.6	33.7	42.5
Max. Overcurrent Protection ²	30	30	35	35	40	45	50	60
SHIPPING WEIGHT (LBS)								
	376	376	385	385	438	492	490	612
ENERGY STAR CERTIFIED								
	NO	NO	NO	NO				NO

¹ Wire size should be determined in accordance with National Electrical Codes. Extensive wire runs will require larger wire sizes.

² May use fuses or HACR-type circuit breakers of the same size as noted.

Note: Always check the S&R plate for electrical data on the unit being installed.

"OTHPPKG" stands for Outdoor Thermostat Heat-Pump Package

IDB	AIRFLOW	OUTDOOR AMBIENT TEMPERATURE																																			
		65°F						75°F						85°F						95°F						105°F						115°F					
		59	63	67	71	59	63	67	71	59	63	67	71	59	63	67	71	59	63	67	71	59	63	67	71	59	63	67	71								
70	950	MBh	23.2	24.0	26.3	-	22.6	23.5	25.7	-	22.1	22.9	25.1	-	21.6	22.3	24.5	-	20.5	21.2	23.3	-	19.0	19.7	21.5	-											
		S/T	0.76	0.63	0.44	-	0.79	0.66	0.46	-	0.81	0.67	0.47	-	0.83	0.70	0.48	-	0.86	0.72	0.50	-	0.87	0.73	0.50	-											
		ΔT	17	15	11	-	17	15	11	-	17	15	11	-	17	15	11	-	17	15	11	-	16	14	11	-											
		kW	1.47	1.50	1.55	-	1.59	1.62	1.67	-	1.69	1.72	1.78	-	1.77	1.81	1.87	-	1.85	1.89	1.95	-	1.91	1.96	2.02	-											
		Amps	6.6	6.7	6.9	-	7.0	7.2	7.3	-	7.5	7.7	7.9	-	8.0	8.1	8.3	-	8.4	8.6	8.8	-	8.8	9.0	9.3	-											
	850	Hi PR	216	233	246	-	243	261	276	-	276	297	314	-	314	338	357	-	354	380	402	-	391	420	444	-											
		Lo PR	111	118	129	-	117	125	136	-	122	130	142	-	128	136	149	-	134	143	156	-	139	148	161	-											
		MBh	22.8	23.7	25.9	-	22.3	23.1	25.3	-	21.8	22.6	24.7	-	21.2	22.0	24.1	-	20.2	20.9	22.9	-	18.7	19.4	21.2	-											
		S/T	0.73	0.61	0.42	-	0.75	0.63	0.44	-	0.77	0.65	0.45	-	0.80	0.67	0.46	-	0.83	0.69	0.48	-	0.84	0.70	0.48	-											
		ΔT	18	16	12	-	18	16	12	-	18	16	12	-	18	16	12	-	18	16	12	-	17	15	11	-											
750	kW	1.47	1.50	1.54	-	1.58	1.61	1.66	-	1.68	1.71	1.77	-	1.76	1.80	1.86	-	1.84	1.88	1.94	-	1.90	1.94	2.01	-												
	Amps	6.5	6.7	6.9	-	7.0	7.1	7.3	-	7.5	7.6	7.8	-	7.9	8.1	8.3	-	8.3	8.5	8.8	-	8.8	9.0	9.2	-												
	Hi PR	215	231	244	-	241	259	274	-	274	295	311	-	312	336	355	-	351	378	399	-	388	417	441	-												
	Lo PR	110	117	128	-	116	124	135	-	121	129	141	-	127	135	148	-	133	142	155	-	138	147	160	-												
	MBh	21.7	22.5	24.6	-	21.2	22.0	24.1	-	20.7	21.4	23.5	-	20.2	20.9	22.9	-	19.2	19.9	21.8	-	17.8	18.4	20.2	-												
75	950	S/T	0.70	0.58	0.40	-	0.72	0.60	0.42	-	0.74	0.62	0.43	-	0.76	0.64	0.44	-	0.79	0.66	0.46	-	0.80	0.67	0.46	-											
		ΔT	19	16	12	-	19	16	12	-	19	16	12	-	19	16	12	-	19	16	12	-	17	15	11	-											
		kW	1.44	1.47	1.52	-	1.55	1.59	1.64	-	1.65	1.68	1.74	-	1.73	1.77	1.83	-	1.81	1.85	1.91	-	1.87	1.91	1.97	-											
		Amps	6.4	6.6	6.7	-	6.9	7.0	7.2	-	7.4	7.5	7.7	-	7.8	7.9	8.2	-	8.2	8.4	8.6	-	8.6	8.8	9.1	-											
		Hi PR	210	226	239	-	236	254	268	-	269	289	305	-	306	329	348	-	344	370	391	-	380	409	432	-											
	850	Lo PR	108	115	125	-	114	121	133	-	119	126	138	-	125	133	145	-	131	139	152	-	135	144	157	-											
		MBh	23.6	24.3	26.3	28.2	23.0	23.7	25.7	27.5	22.5	23.1	25.0	26.9	21.9	22.6	24.4	26.2	20.8	21.4	23.2	24.9	19.3	19.9	21.5	23.1											
		S/T	0.86	0.77	0.58	0.38	0.89	0.80	0.61	0.39	0.92	0.82	0.62	0.40	0.95	0.85	0.64	0.41	0.98	0.88	0.67	0.43	0.99	0.89	0.67	0.43											
		ΔT	20	18	15	10	20	18	15	10	20	18	15	10	20	19	15	10	10	20	18	15	10	19	17	14	10										
		kW	1.49	1.52	1.56	1.61	1.60	1.63	1.69	1.74	1.70	1.74	1.79	1.85	1.79	1.83	1.89	1.95	1.86	1.91	1.97	2.04	1.93	1.97	2.04	2.11											
750	Amps	6.6	6.8	6.9	7.2	7.1	7.2	7.4	7.6	7.6	7.7	7.9	8.2	8.0	8.2	8.4	8.7	8.5	8.6	8.9	9.2	8.9	9.1	9.3	9.7												
	Hi PR	218	235	248	259	245	264	279	290	279	300	317	330	317	342	361	376	357	384	406	423	395	425	448	468												
	Lo PR	112	119	130	139	118	126	138	146	123	131	143	152	129	138	150	160	136	144	157	168	140	149	163	173												
	MBh	23.2	23.9	25.9	27.8	22.7	23.4	25.3	27.1	22.1	22.8	24.7	26.5	21.6	22.2	24.1	25.8	20.5	21.1	22.9	24.5	19.0	19.6	21.2	22.7												
	S/T	0.83	0.74	0.56	0.36	0.86	0.77	0.58	0.37	0.88	0.79	0.59	0.38	0.91	0.81	0.61	0.40	0.94	0.84	0.64	0.41	0.95	0.85	0.64	0.41												
75	950	ΔT	21	19	16	11	21	19	16	11	21	19	16	11	21	20	16	11	21	19	16	11	20	18	15	10											
		kW	1.48	1.51	1.56	1.61	1.59	1.62	1.68	1.73	1.69	1.73	1.78	1.84	1.78	1.82	1.88	1.94	1.85	1.89	1.96	2.02	1.92	1.96	2.03	2.09											
		Amps	6.6	6.7	6.9	7.1	7.0	7.2	7.4	7.6	7.5	7.7	7.9	8.2	8.0	8.1	8.4	8.6	8.4	8.6	8.8	9.1	8.8	9.0	9.3	9.6											
		Hi PR	217	233	246	257	243	262	277	288	277	298	315	328	315	339	358	374	355	382	403	420	392	422	445	464											
		Lo PR	111	118	129	138	118	125	137	145	122	130	142	151	128	137	149	159	135	143	156	166	139	148	162	172											
	850	MBh	22.1	22.7	24.6	26.4	21.5	22.2	24.0	25.8	21.0	21.7	23.4	25.2	20.5	21.1	22.9	24.5	19.5	20.1	21.7	23.3	18.1	18.6	20.1	21.6											
		S/T	0.79	0.71	0.54	0.34	0.82	0.73	0.56	0.36	0.84	0.75	0.57	0.37	0.87	0.78	0.59	0.38	0.90	0.81	0.61	0.39	0.91	0.81	0.62	0.40											
		ΔT	21	20	16	11	22	20	16	11	22	20	16	11	22	20	16	11	22	20	16	11	20	19	15	10											
		kW	1.45	1.48	1.53	1.58	1.56	1.60	1.65	1.70	1.66	1.70	1.75	1.81	1.75	1.79	1.85	1.91	1.82	1.86	1.92	1.99	1.89	1.93	1.99	2.06											
		Amps	6.5	6.6	6.8	7.0	6.9	7.1	7.3	7.5	7.4	7.6	7.8	8.0	7.8	8.0	8.2	8.5	8.3	8.4	8.7	9.0	8.7	8.9	9.1	9.4											
750	Hi PR	213	229	242	252	239	257	271	283	271	292	308	322	309	332	351	366	348	374	395	412	384	413	436	455												
	Lo PR	109	116	127	135	115	123	134	143	120	127	139	148	126	134	146	156	132	140	153	163	136	145	158	169												

IDB: Entering Indoor Dry Bulb Temperature
 High and low pressures are measured at the liquid and suction service valves.
 Design Subcooling 8 ± 2 °F @ the liquid access fitting connection AHRI 95 test conditions. Design Superheat 15 ± 2 °F @ the compressor suction access fitting connection.
 Shaded area reflects ACCA (TVA) conditions.
 kW = Total system power
 Amps = outdoor unit amps (comp.+fan)

IDB	Airflow	OUTDOOR AMBIENT TEMPERATURE												ENTERING INDOOR WET BULB TEMPERATURE											
		65°F				75°F				85°F				95°F				105°F				115°F			
		59	63	67	71	59	63	67	71	59	63	67	71	59	63	67	71	59	63	67	71	59	63	67	71
80	MBh	24.0	24.5	26.2	28.0	23.4	23.9	25.6	27.3	22.9	23.4	25.0	26.7	22.3	22.8	24.4	26.0	21.2	21.7	23.1	24.7	20.1	20.6	22.1	23.7
	S/T	0.95	0.89	0.72	0.54	0.98	0.92	0.75	0.56	1.00	0.94	0.77	0.57	1.00	0.97	0.79	0.59	1.00	1.00	0.82	0.62	1.00	1.00	0.83	0.62
	ΔT	22	21	18	15	22	21	19	15	22	21	19	15	22	21	19	15	21	21	18	15	19	19	17	14
	kW	1.50	1.53	1.58	1.63	1.61	1.65	1.70	1.76	1.71	1.75	1.81	1.87	1.80	1.84	1.90	1.97	1.88	1.92	1.99	2.05	1.95	1.99	2.06	2.13
	Amps	6.7	6.8	7.0	7.2	7.1	7.3	7.5	7.7	7.6	7.8	8.0	8.3	8.1	8.2	8.5	8.8	8.5	8.7	9.0	9.3	9.0	9.2	9.4	9.7
	Hi-PR	221	237	251	261	248	266	281	293	282	303	320	334	321	345	364	380	361	388	410	428	399	429	453	472
	Lo-PR	113	120	132	140	120	127	139	148	124	132	144	154	131	139	152	162	137	146	159	169	142	151	164	175
	MBh	23.6	24.1	25.8	27.6	23.1	23.6	25.2	26.9	22.5	23.0	24.6	26.3	22.0	22.5	24.0	25.7	20.9	21.3	22.8	24.4	19.3	19.8	21.1	22.6
	S/T	0.91	0.85	0.69	0.52	0.94	0.88	0.72	0.54	0.96	0.90	0.74	0.55	0.99	0.93	0.76	0.57	1.00	0.97	0.79	0.59	1.00	0.98	0.79	0.59
	ΔT	23	22	19	15	23	22	20	16	23	23	20	16	24	23	20	16	24	23	22	19	21	21	18	15
kW	1.49	1.52	1.57	1.62	1.60	1.64	1.69	1.75	1.70	1.74	1.80	1.86	1.79	1.83	1.89	1.96	1.87	1.91	1.97	2.04	1.93	1.98	2.04	2.11	
Amps	6.6	6.8	7.0	7.2	7.1	7.2	7.4	7.7	7.6	7.7	8.0	8.2	8.0	8.2	8.4	8.7	8.5	8.7	8.9	9.2	8.9	9.1	9.4	9.7	
Hi-PR	219	236	249	260	246	265	279	291	280	301	318	331	318	343	362	377	358	386	407	425	396	426	450	469	
Lo-PR	112	120	131	139	119	126	138	147	123	131	143	153	130	138	151	160	136	145	158	168	141	150	163	174	
MBh	22.5	22.9	24.5	26.2	21.9	22.4	23.9	25.6	21.4	21.9	23.4	25.0	20.9	21.3	22.8	24.4	19.8	20.3	21.7	23.2	18.4	18.8	20.1	21.4	
S/T	0.87	0.81	0.66	0.50	0.90	0.84	0.69	0.51	0.92	0.87	0.70	0.53	0.95	0.89	0.73	0.54	0.99	0.93	0.75	0.56	1.00	0.94	0.76	0.57	
ΔT	24	23	20	16	24	23	20	16	24	23	20	16	24	23	20	16	24	23	20	16	22	22	19	15	
kW	1.47	1.50	1.54	1.59	1.58	1.61	1.66	1.72	1.68	1.71	1.77	1.83	1.76	1.80	1.86	1.92	1.84	1.88	1.94	2.01	1.90	1.94	2.01	2.08	
Amps	6.5	6.7	6.9	7.1	7.0	7.1	7.3	7.5	7.5	7.6	7.8	8.1	7.9	8.1	8.3	8.6	8.3	8.5	8.8	9.1	8.8	9.0	9.2	9.5	
Hi-PR	215	231	244	254	241	259	274	286	274	295	311	325	312	336	355	370	351	378	399	416	388	417	441	460	
Lo-PR	110	117	128	136	116	124	135	144	121	129	141	150	127	135	148	157	133	142	155	165	138	147	160	170	

950	MBh	24.4	24.9	26.1	27.8	23.8	24.3	25.5	27.2	23.3	23.7	24.8	26.5	22.7	23.1	24.2	25.9	21.6	22.0	23.0	24.6	20.0	20.4	21.3	22.8
	S/T	0.99	0.96	0.86	0.70	1.00	0.99	0.90	0.73	1.00	1.00	0.92	0.75	1.00	1.00	0.95	0.77	1.00	1.00	0.98	0.80	1.00	1.00	0.99	0.81
	ΔT	23	23	22	19	23	23	22	19	23	23	22	19	22	22	22	19	21	21	21	19	19	20	20	18
	kW	1.51	1.54	1.59	1.64	1.63	1.66	1.71	1.77	1.73	1.77	1.82	1.88	1.82	1.86	1.92	1.98	1.90	1.94	2.00	2.07	1.96	2.01	2.07	2.14
	Amps	6.7	6.9	7.0	7.3	7.2	7.3	7.5	7.8	7.7	7.9	8.1	8.3	8.1	8.3	8.6	8.8	8.6	8.8	9.0	9.3	9.0	9.2	9.5	9.8
	Hi-PR	223	240	253	264	250	269	284	296	284	306	323	337	324	349	368	384	364	392	414	432	403	433	457	477
	Lo-PR	114	122	133	141	121	129	140	149	126	134	146	155	132	140	153	163	138	147	161	171	143	152	166	177
	MBh	24.0	24.5	25.7	27.4	23.5	23.9	25.1	26.8	22.9	23.4	24.5	26.1	22.4	22.8	23.9	25.5	21.2	21.7	22.7	24.2	19.7	20.1	21.0	22.4
	S/T	0.95	0.92	0.83	0.67	0.99	0.95	0.86	0.70	1.00	0.97	0.88	0.71	1.00	1.00	0.91	0.74	1.00	1.00	0.94	0.76	1.00	1.00	0.95	0.77
	ΔT	25	24	23	20	25	25	23	20	25	25	23	20	24	25	23	20	23	23	23	20	21	22	22	19
kW	1.50	1.53	1.58	1.63	1.62	1.65	1.70	1.76	1.72	1.76	1.81	1.87	1.81	1.85	1.91	1.97	1.88	1.93	1.99	2.06	1.95	1.99	2.06	2.13	
Amps	6.7	6.8	7.0	7.2	7.1	7.3	7.5	7.7	7.7	7.8	8.0	8.3	8.1	8.3	8.5	8.8	8.5	8.7	9.0	9.3	9.0	9.2	9.4	9.8	
Hi-PR	221	238	251	262	248	267	282	294	282	304	321	335	322	346	365	381	362	389	411	429	400	430	454	474	
Lo-PR	114	121	132	140	120	128	139	148	125	133	145	154	131	139	152	162	137	146	159	170	142	151	165	176	
MBh	22.8	23.3	24.4	26.0	22.3	22.7	23.8	25.4	21.8	22.2	23.3	24.8	21.2	21.7	22.7	24.2	20.2	20.6	21.6	23.0	18.7	19.1	20.0	21.3	
S/T	0.91	0.88	0.79	0.64	0.94	0.91	0.82	0.67	0.97	0.93	0.84	0.68	1.00	0.96	0.87	0.71	1.00	1.00	0.90	0.73	1.00	1.00	0.91	0.74	
ΔT	25	25	24	21	26	25	24	21	26	25	24	21	26	26	24	21	25	25	24	21	23	23	22	19	
kW	1.48	1.51	1.56	1.61	1.59	1.62	1.68	1.73	1.69	1.73	1.78	1.84	1.78	1.82	1.88	1.94	1.85	1.89	1.96	2.02	1.92	1.96	2.03	2.09	
Amps	6.6	6.7	6.9	7.1	7.0	7.2	7.4	7.6	7.5	7.7	7.9	8.2	8.0	8.1	8.4	8.6	8.4	8.6	8.8	9.1	8.8	9.0	9.3	9.6	
Hi-PR	217	233	246	257	243	262	277	288	277	298	314	328	315	339	358	374	355	382	403	420	392	422	445	464	
Lo-PR	111	118	129	138	118	125	137	145	122	130	142	151	128	137	149	159	135	143	156	166	139	148	162	172	

IDB: Entering Indoor Dry Bulb Temperature
 High and low pressures are measured at the liquid and suction service valves.
 Design Subcooling 8 ± 2 °F @ the liquid access fitting connection AHR1 95 test conditions. Design Superheat 15 ± 2 °F @ the compressor suction access fitting connection.
 Shaded area reflects AHR1 conditions.
 kW = Total system power
 Amps = outdoor unit amps (comp.+fan)

IDB	AIRFLOW	OUTDOOR AMBIENT TEMPERATURE																								
		65°F				75°F				85°F				95°F				105°F				115°F				
		59	63	67	71	59	63	67	71	59	63	67	71	59	63	67	71	59	63	67	71	59	63	67	71	
70	1175	MBh	28.0	29.0	31.8	-	27.4	28.4	31.1	-	26.7	27.7	30.3	-	26.0	27.0	29.6	-	24.7	25.7	28.1	-	22.9	23.8	26.0	-
		S/T	0.75	0.63	0.44	-	0.78	0.65	0.45	-	0.80	0.67	0.46	-	0.83	0.69	0.48	-	0.86	0.72	0.50	-	0.86	0.72	0.50	-
		ΔT	16	14	11	-	17	14	11	-	17	14	11	-	17	15	11	-	17	14	11	-	15	13	10	-
		kW	1.89	1.94	2.00	-	2.04	2.09	2.16	-	2.17	2.22	2.30	-	2.29	2.34	2.42	-	2.39	2.44	2.52	-	2.47	2.53	2.61	-
		Amps	8.3	8.5	8.7	-	8.9	9.1	9.3	-	9.6	9.8	10.0	-	10.1	10.3	10.6	-	10.7	10.9	11.3	-	11.3	11.5	11.9	-
		Hi/PR	228	245	259	-	255	275	290	-	290	313	330	-	331	356	376	-	372	400	423	-	411	442	467	-
	Lo/PR	109	115	126	-	115	122	133	-	119	127	138	-	125	133	145	-	131	140	152	-	136	144	158	-	
	MBh	27.6	28.6	31.3	-	26.9	27.9	30.6	-	26.3	27.3	29.9	-	25.7	26.6	29.1	-	24.4	25.3	27.7	-	22.6	23.4	25.6	-	
	S/T	0.72	0.60	0.42	-	0.75	0.62	0.43	-	0.77	0.64	0.44	-	0.79	0.66	0.46	-	0.82	0.68	0.47	-	0.83	0.69	0.48	-	
	ΔT	17	15	11	-	18	15	12	-	18	15	12	-	18	15	12	-	18	15	12	-	16	14	11	-	
	kW	1.88	1.92	1.99	-	2.03	2.08	2.14	-	2.16	2.21	2.28	-	2.28	2.33	2.40	-	2.37	2.43	2.51	-	2.46	2.51	2.60	-	
	Amps	8.3	8.4	8.7	-	8.8	9.0	9.3	-	9.5	9.7	10.0	-	10.1	10.3	10.6	-	10.6	10.9	11.2	-	11.2	11.4	11.8	-	
Hi/PR	226	243	257	-	254	273	288	-	288	310	328	-	328	353	373	-	370	398	420	-	408	439	464	-		
Lo/PR	108	115	125	-	114	121	132	-	118	126	137	-	124	132	144	-	130	139	151	-	135	143	157	-		
MBh	26.2	27.2	29.8	-	25.6	26.5	29.1	-	25.0	25.9	28.4	-	24.4	25.3	27.7	-	23.2	24.0	26.3	-	21.5	22.2	24.4	-		
S/T	0.69	0.58	0.40	-	0.72	0.60	0.41	-	0.73	0.61	0.42	-	0.76	0.63	0.44	-	0.79	0.66	0.45	-	0.79	0.66	0.46	-		
ΔT	18	16	12	-	18	16	12	-	18	16	12	-	18	16	12	-	18	16	12	-	17	15	11	-		
kW	1.85	1.89	1.95	-	2.00	2.04	2.11	-	2.13	2.17	2.24	-	2.24	2.29	2.36	-	2.33	2.39	2.47	-	2.42	2.47	2.55	-		
Amps	8.1	8.3	8.5	-	8.7	8.9	9.1	-	9.4	9.5	9.8	-	9.9	10.1	10.4	-	10.5	10.7	11.0	-	11.0	11.3	11.6	-		
Hi/PR	221	238	252	-	248	267	282	-	283	304	321	-	322	346	366	-	362	390	412	-	400	431	455	-		
Lo/PR	106	112	123	-	112	119	130	-	116	123	135	-	122	130	142	-	128	136	148	-	132	141	153	-		

75	1175	MBh	28.5	29.3	31.7	34.1	27.8	28.6	31.0	33.3	27.2	28.0	30.3	32.5	26.5	27.3	29.5	31.7	25.2	25.9	28.0	30.1	23.3	24.0	26.0	27.9	
		S/T	0.86	0.76	0.58	0.37	0.89	0.79	0.60	0.39	0.91	0.81	0.62	0.40	0.94	0.84	0.63	0.41	0.97	0.87	0.66	0.42	0.98	0.88	0.66	0.43	
		ΔT	19	18	14	10	19	18	15	10	19	18	15	10	19	18	15	10	19	18	14	10	18	16	14	9	
		kW	1.91	1.95	2.01	2.08	2.06	2.11	2.17	2.25	2.25	2.19	2.24	2.32	2.39	2.31	2.36	2.44	2.52	2.41	2.46	2.55	2.63	2.49	2.55	2.64	2.73
		Amps	8.4	8.6	8.8	9.1	9.0	9.1	9.4	9.7	9.6	9.8	10.1	10.5	10.2	10.4	10.7	11.1	11.4	10.8	11.0	11.4	11.7	11.4	11.6	12.0	12.4
		Hi/PR	230	247	261	272	258	278	293	306	324	293	316	333	348	334	360	380	396	376	405	427	446	415	447	472	492
	Lo/PR	110	117	127	136	116	123	135	143	120	128	140	149	126	135	147	156	156	133	141	154	164	137	146	159	170	
	MBh	28.1	28.9	31.3	33.6	27.4	28.2	30.5	32.8	26.8	27.5	29.8	32.0	26.1	26.9	29.1	31.2	24.8	25.5	27.6	29.7	23.0	23.6	25.6	27.5		
	S/T	0.82	0.73	0.55	0.36	0.85	0.76	0.57	0.37	0.87	0.78	0.59	0.38	0.90	0.80	0.61	0.39	0.93	0.83	0.63	0.41	0.94	0.84	0.64	0.41		
	ΔT	20	19	15	10	20	19	15	11	20	19	15	11	20	19	15	11	20	19	15	11	19	17	14	10		
	kW	1.90	1.94	2.00	2.07	2.05	2.09	2.16	2.23	2.18	2.23	2.30	2.38	2.30	2.30	2.35	2.43	2.51	2.39	2.45	2.53	2.62	2.48	2.54	2.62	2.71	
	Amps	8.3	8.5	8.7	9.0	8.9	9.1	9.4	9.7	9.6	9.8	10.1	10.4	10.2	10.4	10.7	11.0	11.0	10.7	11.0	11.3	11.7	11.3	11.5	11.9	12.3	
Hi/PR	228	246	259	271	256	276	291	304	291	314	331	345	332	357	377	393	373	402	424	442	442	412	444	469	489		
Lo/PR	109	116	126	135	115	122	134	142	120	127	139	148	126	134	146	155	155	132	140	153	163	136	145	158	168		
MBh	26.7	27.4	29.7	31.9	26.0	26.8	29.0	31.1	25.4	26.2	28.3	30.4	24.8	25.5	27.6	29.7	23.6	24.3	26.3	28.2	21.8	22.5	24.3	26.1			
S/T	0.78	0.70	0.53	0.34	0.81	0.73	0.55	0.35	0.83	0.75	0.56	0.36	0.86	0.77	0.58	0.37	0.89	0.80	0.60	0.39	0.90	0.81	0.61	0.39			
ΔT	21	19	16	11	21	19	16	11	21	19	16	11	21	20	16	11	21	19	16	11	20	18	15	10			
kW	1.87	1.91	1.97	2.03	2.01	2.06	2.13	2.20	2.14	2.19	2.26	2.34	2.26	2.31	2.38	2.46	2.35	2.41	2.49	2.57	2.44	2.49	2.58	2.66			
Amps	8.2	8.4	8.6	8.9	8.8	9.0	9.2	9.5	9.4	9.6	9.9	10.2	10.0	10.2	10.5	10.9	10.6	10.8	11.1	11.5	11.1	11.3	11.7	12.1			
Hi/PR	224	241	254	265	251	270	285	298	286	307	324	338	325	350	370	385	366	394	416	434	404	435	459	479			
Lo/PR	107	114	124	132	113	120	131	139	117	125	136	145	123	131	143	152	129	137	150	160	133	142	155	165			

IDB: Entering Indoor Dry Bulb Temperature
 High and low pressures are measured at the liquid and suction service valves.
 Design Subcooling, 10 ± 2 °F @ the liquid access fitting connection AHR1 95 test conditions. Design Superheat 15 ± 2 °F @ the compressor suction access fitting connection.
 Shaded area reflects ACCA (TVA) conditions.
 kW = Total system power
 Amps = outdoor unit amps (comp.+fan)

IDB	AIRFLOW	OUTDOOR AMBIENT TEMPERATURE												ENTERING INDOOR WET BULB TEMPERATURE												
		65°F				75°F				85°F				95°F				105°F				115°F				
		59	63	67	71	59	63	67	71	59	63	67	71	59	63	67	71	59	63	67	71	59	63	67	71	
80	1175	MBh	29.0	29.6	31.6	33.8	28.3	28.9	30.9	33.0	27.6	28.2	30.2	32.3	27.0	27.6	29.4	31.5	25.6	26.2	28.0	29.9	23.7	24.2	25.9	27.7
		S/T	0.94	0.88	0.72	0.54	0.97	0.91	0.74	0.55	1.00	0.93	0.76	0.57	1.00	0.96	0.79	0.59	1.00	1.00	0.82	0.61	1.00	1.00	0.82	0.61
	ΔT	21	20	18	14	22	21	18	14	22	21	18	14	21	21	18	14	20	20	18	14	19	19	17	13	
	kW	1.93	1.97	2.03	2.10	2.08	2.12	2.19	2.27	2.21	2.26	2.33	2.41	2.33	2.38	2.46	2.54	2.43	2.48	2.57	2.66	2.52	2.57	2.66	2.75	
	Amps	8.4	8.6	8.9	9.1	9.0	9.2	9.5	9.8	9.7	9.9	10.2	10.5	10.3	10.5	10.8	11.2	10.9	11.1	11.4	11.8	11.5	11.7	12.1	12.5	
	Hi PR	232	250	264	275	261	280	296	309	296	319	337	351	338	363	384	400	380	409	431	450	420	451	477	497	
	Lo PR	111	118	129	137	117	125	136	145	122	129	141	150	128	136	148	158	134	142	156	166	139	147	161	171	
	MBh	28.6	29.2	31.2	33.3	27.9	28.5	30.5	32.6	27.2	27.8	29.7	31.8	26.6	27.1	29.0	31.0	25.2	25.8	27.6	29.5	23.4	23.9	25.5	27.3	
	S/T	0.90	0.84	0.69	0.51	0.93	0.87	0.71	0.53	0.95	0.90	0.73	0.54	0.99	0.92	0.75	0.56	1.00	0.96	0.78	0.58	1.00	0.97	0.79	0.59	
	ΔT	22	22	19	15	23	22	19	15	23	22	19	15	23	22	19	15	22	22	19	15	20	20	18	14	
kW	1.92	1.96	2.02	2.09	2.07	2.11	2.18	2.25	2.20	2.25	2.32	2.40	2.31	2.37	2.45	2.53	2.41	2.47	2.55	2.64	2.50	2.56	2.64	2.73		
Amps	8.4	8.6	8.8	9.1	9.0	9.2	9.4	9.7	9.7	9.9	10.1	10.5	10.2	10.5	10.8	11.1	10.8	11.1	11.4	11.8	11.4	11.6	12.0	12.4		
Hi PR	231	248	262	273	259	278	294	307	294	317	334	349	335	361	381	397	377	406	428	447	417	448	473	494		
Lo PR	110	117	128	136	116	124	135	144	121	129	140	149	127	135	147	157	133	141	154	164	138	146	160	170		
MBh	27.1	27.7	29.6	31.7	26.5	27.1	28.9	30.9	25.9	26.4	28.2	30.2	25.2	25.8	27.6	29.5	24.0	24.5	26.2	28.0	22.2	22.7	24.2	25.9		
S/T	0.86	0.81	0.66	0.49	0.89	0.84	0.68	0.51	0.91	0.86	0.70	0.52	0.94	0.88	0.72	0.54	0.98	0.92	0.75	0.56	0.99	0.93	0.75	0.56		
ΔT	23	22	19	15	23	23	20	16	24	23	20	16	24	23	20	16	23	22	19	16	22	21	18	15		
kW	1.88	1.92	1.99	2.05	2.03	2.08	2.14	2.21	2.16	2.21	2.28	2.36	2.28	2.33	2.40	2.49	2.37	2.43	2.51	2.59	2.46	2.51	2.60	2.69		
Amps	8.3	8.4	8.7	9.0	8.8	9.0	9.3	9.6	9.5	9.7	10.0	10.3	10.1	10.3	10.6	10.9	10.6	10.9	11.2	11.6	11.2	11.4	11.8	12.2		
Hi PR	226	243	257	268	254	273	288	301	288	310	328	342	328	353	373	389	370	398	420	438	408	439	464	484		
Lo PR	108	115	125	133	114	121	132	141	118	126	137	146	124	132	144	154	130	139	151	161	135	143	157	167		

85	1175	MBh	29.5	30.1	31.5	33.6	28.8	29.4	30.8	32.8	28.1	28.7	30.0	32.0	27.4	28.0	29.3	31.2	26.1	26.6	27.8	29.7	24.1	24.6	25.8	27.5
		S/T	0.98	0.95	0.86	0.69	1.00	0.98	0.89	0.72	1.00	1.00	0.91	0.74	1.00	1.00	0.94	0.76	1.00	1.00	0.97	0.79	1.00	1.00	0.98	0.80
	ΔT	23	22	21	18	23	23	21	18	22	22	21	18	21	22	22	19	20	21	21	18	19	19	20	17	
	kW	1.94	1.98	2.05	2.11	2.09	2.14	2.21	2.28	2.23	2.28	2.35	2.43	2.35	2.40	2.48	2.57	2.45	2.50	2.59	2.68	2.54	2.59	2.68	2.78	
	Amps	8.5	8.7	8.9	9.2	9.1	9.3	9.6	9.9	9.8	10.0	10.3	10.6	10.4	10.6	10.9	11.3	11.0	11.2	11.5	11.9	11.5	11.8	12.2	12.6	
	Hi PR	235	252	267	278	263	283	299	312	299	322	340	355	341	367	387	404	383	413	436	455	424	456	481	502	
	Lo PR	112	119	130	138	118	126	137	146	123	131	143	152	129	137	150	160	135	144	157	167	140	149	162	173	
	MBh	29.1	29.6	31.0	33.1	28.4	28.9	30.3	32.3	27.7	28.2	29.6	31.6	27.0	27.6	28.9	30.8	25.7	26.2	27.4	29.2	23.8	24.2	25.4	27.1	
	S/T	0.94	0.91	0.82	0.67	0.98	0.94	0.85	0.69	1.00	0.97	0.87	0.71	1.00	1.00	0.90	0.73	1.00	1.00	0.93	0.76	1.00	1.00	0.94	0.76	
	ΔT	24	24	22	19	24	24	23	20	24	24	23	20	24	24	23	20	22	23	22	19	21	21	21	18	
kW	1.93	1.97	2.04	2.10	2.08	2.13	2.20	2.27	2.22	2.27	2.34	2.42	2.33	2.39	2.47	2.55	2.43	2.49	2.57	2.66	2.52	2.58	2.67	2.76		
Amps	8.5	8.6	8.9	9.2	9.1	9.2	9.5	9.8	9.7	9.9	10.2	10.6	10.3	10.5	10.9	11.2	10.9	11.1	11.5	11.9	11.5	11.7	12.1	12.5		
Hi PR	233	251	265	276	261	281	297	310	297	320	338	352	339	364	385	401	381	410	433	451	421	453	478	499		
Lo PR	111	118	129	137	117	125	136	145	122	130	142	151	128	136	149	159	134	143	156	166	139	148	161	172		
MBh	27.6	28.1	29.5	31.4	27.0	27.5	28.8	30.7	26.3	26.8	28.1	30.0	25.7	26.2	27.4	29.2	24.4	24.9	26.0	27.8	22.6	23.0	24.1	25.7		
S/T	0.90	0.87	0.79	0.64	0.93	0.90	0.81	0.66	0.96	0.92	0.83	0.68	0.99	0.95	0.86	0.70	1.00	0.99	0.89	0.73	1.00	1.00	0.90	0.73		
ΔT	25	24	23	20	25	25	23	20	25	25	23	20	25	25	23	20	24	24	23	20	22	23	22	19		
kW	1.90	1.94	2.00	2.07	2.05	2.09	2.16	2.23	2.18	2.23	2.30	2.38	2.30	2.35	2.42	2.51	2.39	2.45	2.53	2.62	2.48	2.53	2.62	2.71		
Amps	8.3	8.5	8.7	9.0	8.9	9.1	9.4	9.7	9.6	9.8	10.1	10.4	10.2	10.4	10.7	11.0	10.7	11.0	11.3	11.7	11.3	11.5	11.9	12.3		
Hi PR	228	246	259	271	256	276	291	304	291	313	331	345	332	357	377	393	373	402	424	442	412	444	469	489		
Lo PR	109	116	126	135	115	122	134	142	120	127	139	148	126	134	146	155	132	140	153	163	136	145	158	168		

IDB: Entering Indoor Dry Bulb Temperature
 High and low pressures are measured at the liquid and suction service valves.
 Design Subcooling, 10 ± 2 °F @ the liquid access fitting connection AHRI 95 test conditions. Design Superheat 15 ± 2 °F @ the compressor suction access fitting connection.
 Shaded area reflects AHRI conditions.
 kW = Total system power
 Amps = outdoor unit amps (comp.+fan)

IDB	AIRFLOW	OUTDOOR AMBIENT TEMPERATURE												ENTERING INDOOR WET BULB TEMPERATURE												
		65°F				75°F				85°F				95°F				105°F				115°F				
		59	63	67	71	59	63	67	71	59	63	67	71	59	63	67	71	59	63	67	71	59	63	67	71	
70	1350	MBh	34.3	35.5	38.9	-	33.5	34.7	38.0	-	32.7	33.9	37.1	-	31.9	33.1	36.2	-	30.3	31.4	34.4	-	28.1	29.1	31.9	-
		S/T	0.75	0.63	0.43	-	0.78	0.65	0.45	-	0.80	0.66	0.46	-	0.82	0.69	0.48	-	0.85	0.71	0.49	-	0.86	0.72	0.50	-
		ΔT	17	15	11	-	18	15	12	-	18	15	12	-	18	15	12	-	18	15	12	-	16	14	11	-
		kW	2.26	2.31	2.38	-	2.44	2.49	2.57	-	2.60	2.65	2.74	-	2.73	2.80	2.89	-	2.85	2.92	3.02	-	2.95	3.02	3.12	-
		Amps	10.1	10.3	10.6	-	10.8	11.0	11.3	-	11.6	11.8	12.2	-	12.3	12.5	12.9	-	13.0	13.2	13.6	-	13.6	13.9	14.4	-
		Hi PR	240	258	273	-	269	290	306	-	306	329	348	-	349	375	396	-	392	422	446	-	433	466	493	-
	Lo PR	112	119	130	-	118	125	137	-	123	130	142	-	129	137	150	-	135	144	157	-	140	148	162	-	
	MBh	33.3	34.5	37.8	-	32.5	33.7	36.9	-	31.7	32.9	36.1	-	31.0	32.1	35.2	-	29.4	30.5	33.4	-	27.3	28.3	31.0	-	
	S/T	0.71	0.60	0.41	-	0.74	0.62	0.43	-	0.76	0.63	0.44	-	0.78	0.65	0.45	-	0.81	0.68	0.47	-	0.82	0.68	0.47	-	
	ΔT	18	16	12	-	18	16	12	-	18	16	12	-	19	16	12	-	18	16	12	-	17	15	11	-	
	kW	2.24	2.29	2.37	-	2.42	2.47	2.55	-	2.57	2.63	2.72	-	2.71	2.77	2.87	-	2.83	2.89	2.99	-	2.93	3.00	3.10	-	
	Amps	10.0	10.2	10.5	-	10.7	10.9	11.2	-	11.5	11.7	12.1	-	12.2	12.4	12.8	-	12.9	13.1	13.5	-	13.5	13.8	14.2	-	
Hi PR	238	256	270	-	267	287	303	-	303	326	344	-	345	372	392	-	388	418	441	-	429	462	488	-		
Lo PR	111	118	128	-	117	124	136	-	121	129	141	-	127	136	148	-	134	142	155	-	138	147	160	-		
MBh	31.6	32.8	35.9	-	30.9	32.0	35.1	-	30.2	31.3	34.3	-	29.4	30.5	33.4	-	28.0	29.0	31.7	-	25.9	26.8	29.4	-		
S/T	0.68	0.57	0.40	-	0.71	0.59	0.41	-	0.73	0.61	0.42	-	0.75	0.63	0.43	-	0.78	0.65	0.45	-	0.79	0.66	0.45	-		
ΔT	19	16	12	-	19	16	12	-	19	16	12	-	19	17	13	-	19	16	12	-	18	15	12	-		
kW	2.21	2.25	2.33	-	2.38	2.43	2.51	-	2.53	2.59	2.67	-	2.67	2.73	2.82	-	2.78	2.84	2.94	-	2.88	2.94	3.04	-		
Amps	9.9	10.1	10.3	-	10.5	10.7	11.0	-	11.3	11.5	11.9	-	12.0	12.2	12.6	-	12.6	12.9	13.3	-	13.3	13.6	14.0	-		
Hi PR	233	251	265	-	261	281	297	-	297	320	338	-	338	364	384	-	381	410	433	-	421	453	478	-		
Lo PR	108	115	126	-	114	122	133	-	119	127	138	-	125	133	145	-	131	139	152	-	135	144	157	-		

75	1350	MBh	34.9	35.9	38.9	41.7	34.1	35.1	38.0	40.7	33.3	34.2	37.1	39.8	32.4	33.4	36.2	38.8	30.8	31.7	34.4	36.9	28.6	29.4	31.8	34.2
		S/T	0.85	0.76	0.58	0.37	0.88	0.79	0.60	0.38	0.90	0.81	0.61	0.39	0.93	0.84	0.63	0.41	0.97	0.87	0.66	0.42	0.98	0.87	0.66	0.43
		ΔT	20	19	15	11	20	19	15	11	20	19	15	11	21	19	16	11	20	19	15	11	19	17	14	10
		kW	2.28	2.33	2.40	2.48	2.46	2.51	2.60	2.68	2.62	2.68	2.77	2.86	2.76	2.82	2.91	3.01	2.88	2.94	3.04	3.15	2.98	3.05	3.15	3.26
		Amps	10.2	10.4	10.7	11.0	10.9	11.1	11.4	11.8	11.7	11.9	12.3	12.7	12.4	12.6	13.0	13.4	13.1	13.4	13.8	14.2	13.8	14.1	14.5	15.0
		Hi PR	242	261	275	287	272	293	309	322	309	333	351	367	352	379	400	418	396	426	450	470	438	471	498	519
	Lo PR	113	120	131	139	119	127	138	147	124	132	144	153	130	138	151	161	136	145	158	169	141	150	164	174	
	MBh	33.9	34.9	37.7	40.5	33.1	34.1	36.9	39.6	32.3	33.2	36.0	38.6	31.5	32.4	35.1	37.7	29.9	30.8	33.3	35.8	27.7	28.5	30.9	33.2	
	S/T	0.81	0.73	0.55	0.35	0.84	0.75	0.57	0.37	0.86	0.77	0.58	0.38	0.89	0.80	0.60	0.39	0.92	0.83	0.63	0.40	0.93	0.83	0.63	0.41	
	ΔT	21	19	16	11	21	20	16	11	21	20	16	11	21	20	16	11	21	20	16	11	20	18	15	10	
	kW	2.26	2.31	2.38	2.46	2.44	2.49	2.57	2.66	2.60	2.65	2.74	2.83	2.73	2.80	2.89	2.99	2.85	2.92	3.02	3.12	2.95	3.02	3.12	3.23	
	Amps	10.1	10.3	10.6	10.9	10.8	11.0	11.3	11.7	11.6	11.8	12.2	12.6	12.3	12.5	12.9	13.3	13.0	13.2	13.6	14.1	13.6	13.9	14.4	14.9	
Hi PR	240	258	273	284	269	290	306	319	306	330	348	363	349	375	396	413	392	422	446	465	434	467	493	514		
Lo PR	112	119	130	138	118	125	137	146	123	130	142	152	129	137	150	159	135	144	157	167	140	148	162	173		
MBh	32.2	33.1	35.9	38.5	31.4	32.4	35.0	37.6	30.7	31.6	34.2	36.7	29.9	30.8	33.3	35.8	28.4	29.3	31.7	34.0	26.3	27.1	29.3	31.5		
S/T	0.78	0.70	0.53	0.34	0.81	0.72	0.55	0.35	0.83	0.74	0.56	0.36	0.85	0.76	0.58	0.37	0.89	0.79	0.60	0.39	0.89	0.80	0.60	0.39		
ΔT	22	20	16	11	22	20	17	11	22	20	17	11	22	20	17	12	22	20	16	11	20	19	15	11		
kW	2.22	2.27	2.35	2.42	2.40	2.45	2.53	2.62	2.55	2.61	2.70	2.79	2.69	2.75	2.84	2.94	2.80	2.87	2.96	3.07	2.90	2.97	3.07	3.18		
Amps	9.9	10.1	10.4	10.7	10.6	10.8	11.1	11.5	11.4	11.6	12.0	12.4	12.1	12.3	12.7	13.1	12.8	13.0	13.4	13.9	13.4	13.7	14.1	14.6		
Hi PR	235	253	267	279	264	284	300	313	300	323	341	356	342	368	388	405	385	414	437	456	425	457	483	504		
Lo PR	109	116	127	135	116	123	134	143	120	128	140	149	126	134	147	156	132	141	154	164	137	146	159	169		

IDB: Entering Indoor Dry Bulb Temperature
 High and low pressures are measured at the liquid and suction service valves.
 Design Subcooling 10 ±2 °F @ the liquid access fitting connection A4R1 95 test conditions. Design Superheat 13 ±2 °F @ the compressor suction access fitting connection.
 Shaded area reflects ACCA (TVA) conditions.
 kW = Total system power
 Amps = outdoor unit amps (comp.+fan)

IDB	AIRFLOW	OUTDOOR AMBIENT TEMPERATURE												ENTERING INDOOR WET BULB TEMPERATURE											
		65°F				75°F				85°F				95°F				105°F				115°F			
		59	63	67	71	59	63	67	71	59	63	67	71	59	63	67	71	59	63	67	71	59	63	67	71
80	MBh	35.5	36.3	38.8	41.4	34.7	35.4	37.9	40.5	33.8	34.6	37.0	39.5	33.0	33.7	36.1	38.5	31.4	32.1	34.2	36.6	29.1	29.7	31.7	33.9
	S/T	0.93	0.88	0.71	0.53	0.97	0.91	0.74	0.55	1.00	0.93	0.76	0.57	1.00	0.96	0.78	0.58	1.00	1.00	0.81	0.61	1.00	1.00	0.82	0.61
	ΔT	23	22	19	15	23	22	19	15	23	22	19	15	22	22	19	15	21	22	19	15	20	20	18	14
	kW	2.30	2.35	2.42	2.50	2.48	2.53	2.62	2.71	2.64	2.70	2.79	2.88	2.78	2.84	2.94	3.04	2.90	2.97	3.07	3.17	3.01	3.07	3.18	3.29
	Amps	10.2	10.5	10.7	11.1	10.9	11.2	11.5	11.9	11.8	12.0	12.4	12.8	12.5	12.7	13.1	13.6	13.2	13.5	13.9	14.3	13.9	14.2	14.6	15.1
	Hi PR	245	263	278	290	275	296	312	326	312	336	355	370	356	383	404	422	400	431	455	474	442	476	503	524
	Lo PR	114	121	132	141	120	128	140	149	125	133	145	155	131	140	153	162	138	146	160	170	142	151	165	176
	MBh	34.5	35.2	37.6	40.2	33.7	34.4	36.8	39.3	32.9	33.6	35.9	38.4	32.1	32.8	35.0	37.4	30.5	31.1	33.3	35.5	28.2	28.8	30.8	32.9
	S/T	0.89	0.83	0.68	0.51	0.92	0.87	0.70	0.53	0.95	0.89	0.72	0.54	0.98	0.92	0.75	0.56	1.00	0.95	0.77	0.58	1.00	0.96	0.78	0.58
	ΔT	24	23	20	16	24	23	20	16	24	23	20	16	24	23	20	16	23	23	20	16	22	21	18	15
	kW	2.28	2.33	2.40	2.48	2.46	2.51	2.60	2.68	2.62	2.68	2.77	2.86	2.76	2.82	2.92	3.01	2.88	2.94	3.04	3.15	2.98	3.05	3.15	3.26
	Amps	10.2	10.4	10.7	11.0	10.9	11.1	11.4	11.8	11.7	11.9	12.3	12.7	12.4	12.6	13.0	13.4	13.1	13.4	13.8	14.2	13.8	14.1	14.5	15.0
Hi PR	242	261	275	287	272	293	309	322	309	333	352	367	352	379	400	418	396	427	450	470	438	471	498	519	
Lo PR	113	120	131	139	119	127	138	147	124	132	144	153	130	138	151	161	136	145	158	169	141	150	164	174	
MBh	32.7	33.5	35.7	38.2	32.0	32.7	34.9	37.3	31.2	31.9	34.1	36.4	30.5	31.1	33.3	35.5	28.9	29.6	31.6	33.8	26.8	27.4	29.3	31.3	
S/T	0.85	0.80	0.65	0.49	0.88	0.83	0.67	0.50	0.91	0.85	0.69	0.52	0.94	0.88	0.71	0.53	0.97	0.91	0.74	0.55	0.98	0.92	0.75	0.56	
ΔT	24	23	20	16	25	23	20	16	25	24	20	16	25	24	21	16	24	23	20	16	23	22	19	15	
kW	2.24	2.29	2.37	2.44	2.42	2.47	2.55	2.64	2.57	2.63	2.72	2.81	2.71	2.77	2.87	2.96	2.83	2.89	2.99	3.09	2.93	3.00	3.10	3.20	
Amps	10.0	10.2	10.5	10.8	10.7	10.9	11.2	11.6	11.5	11.7	12.1	12.5	12.2	12.4	12.8	13.2	12.9	13.1	13.5	14.0	13.5	13.8	14.2	14.7	
Hi PR	238	256	270	282	267	287	303	316	303	326	344	359	345	372	392	409	388	418	441	460	429	462	488	509	
Lo PR	111	118	128	137	117	124	136	144	121	129	141	150	127	136	148	158	134	142	155	165	138	147	160	171	
85	MBh	36.1	36.8	38.6	41.1	35.3	36.0	37.7	40.2	34.4	35.1	36.8	39.2	33.6	34.2	35.9	38.3	31.9	32.5	34.1	36.4	29.6	30.1	31.6	33.7
	S/T	0.98	0.94	0.85	0.69	1.00	0.98	0.88	0.72	1.00	1.00	0.91	0.73	1.00	1.00	0.93	0.76	1.00	1.00	0.97	0.79	1.00	1.00	0.98	0.79
	ΔT	24	24	22	19	24	24	23	20	23	24	23	20	23	23	23	20	22	22	23	19	20	21	21	18
	kW	2.32	2.37	2.44	2.53	2.50	2.56	2.64	2.73	2.66	2.72	2.81	2.91	2.81	2.87	2.97	3.07	2.93	2.99	3.09	3.20	3.03	3.10	3.21	3.32
	Amps	10.3	10.5	10.8	11.2	11.0	11.3	11.6	12.0	11.9	12.1	12.5	12.9	12.6	12.8	13.2	13.7	13.3	13.6	14.0	14.5	14.0	14.3	14.7	15.2
	Hi PR	247	266	281	293	277	299	315	329	316	340	359	374	359	387	408	426	404	435	459	479	447	481	508	529
	Lo PR	115	122	134	142	122	129	141	150	126	134	147	156	133	141	154	164	139	148	161	172	144	153	167	178
	MBh	35.1	35.7	37.4	39.9	34.3	34.9	36.6	39.0	33.4	34.1	35.7	38.1	32.6	33.3	34.8	37.2	31.0	31.6	33.1	35.3	28.7	29.3	30.6	32.7
	S/T	0.93	0.90	0.81	0.66	0.97	0.93	0.84	0.68	0.99	0.96	0.86	0.70	1.00	0.99	0.89	0.72	1.00	1.00	0.93	0.75	1.00	1.00	0.93	0.76
	ΔT	25	25	23	20	25	25	24	20	25	25	24	20	25	25	24	21	24	24	23	20	22	22	22	19
	kW	2.30	2.35	2.42	2.50	2.48	2.53	2.62	2.71	2.64	2.70	2.79	2.88	2.78	2.84	2.94	3.04	2.90	2.97	3.07	3.17	3.01	3.07	3.18	3.29
	Amps	10.2	10.5	10.7	11.1	10.9	11.2	11.5	11.9	11.8	12.0	12.4	12.8	12.5	12.7	13.1	13.6	13.2	13.5	13.9	14.3	13.9	14.2	14.6	15.1
Hi PR	245	263	278	290	275	296	312	326	312	336	355	370	356	383	404	422	400	431	455	474	442	476	503	524	
Lo PR	114	121	132	141	120	128	140	149	125	133	145	155	131	140	153	162	138	146	160	170	142	151	165	176	
MBh	33.3	34.0	35.6	37.9	32.5	33.2	34.7	37.1	31.8	32.4	33.9	36.2	31.0	31.6	33.1	35.3	29.4	30.0	31.4	33.5	27.3	27.8	29.1	31.1	
S/T	0.89	0.86	0.78	0.63	0.93	0.89	0.81	0.65	0.95	0.92	0.83	0.67	0.98	0.95	0.85	0.69	1.00	0.98	0.89	0.72	1.00	0.99	0.89	0.73	
ΔT	26	25	24	21	26	26	24	21	26	26	24	21	26	26	25	21	26	26	24	21	24	24	23	20	
kW	2.26	2.31	2.38	2.46	2.44	2.49	2.57	2.66	2.60	2.65	2.74	2.83	2.73	2.80	2.89	2.99	2.85	2.92	3.02	3.12	2.95	3.02	3.12	3.23	
Amps	10.1	10.3	10.6	10.9	10.8	11.0	11.3	11.7	11.6	11.8	12.2	12.6	12.3	12.5	12.9	13.3	13.0	13.2	13.6	14.1	13.6	13.9	14.4	14.9	
Hi PR	240	258	273	284	269	290	306	319	306	329	348	363	349	375	396	413	392	422	446	465	433	466	493	514	
Lo PR	112	119	130	138	118	125	137	146	123	130	142	152	129	137	150	159	135	144	157	167	140	148	162	173	

IDB: Entering Indoor Dry Bulb Temperature
 High and low pressures are measured at the liquid and suction service valves.
 Design Subcooling 10 ±2 °F @ the liquid access fitting connection AHR1 95 test conditions. Design Superheat 13 ±2 °F @ the compressor suction access fitting connection.
 Shaded area reflects AHR1 conditions.
 Amps = outdoor unit amps (comp.+fan)
 kW = Total system power

IDB	AIRFLOW	OUTDOOR AMBIENT TEMPERATURE																								
		65°F				75°F				85°F				95°F				105°F				115°F				
		59	63	67	71	59	63	67	71	59	63	67	71	59	63	67	71	59	63	67	71	59	63	67	71	
70	1450	MBh	39.6	41.0	45.0	-	38.7	40.1	43.9	-	37.8	39.1	42.9	-	36.8	38.2	41.8	-	35.0	36.3	39.7	-	32.4	33.6	36.8	-
		S/T	0.73	0.61	0.42	-	0.76	0.63	0.44	-	0.78	0.65	0.45	-	0.80	0.67	0.46	-	0.83	0.69	0.48	-	0.84	0.70	0.48	-
		ΔT	18	16	12	-	19	16	12	-	19	16	12	-	19	16	12	-	18	16	12	-	17	15	11	-
		KW	2.65	2.71	2.79	-	2.86	2.92	3.02	-	3.04	3.11	3.21	-	3.21	3.28	3.39	-	3.34	3.42	3.54	-	3.46	3.54	3.66	-
		Amps	11.5	11.7	12.1	-	12.3	12.6	12.9	-	13.3	13.5	13.9	-	14.1	14.4	14.8	-	14.9	15.2	15.7	-	15.7	16.0	16.5	-
	1300	Hi PR	233	251	265	-	262	282	298	-	298	321	338	-	339	365	386	-	382	411	434	-	422	454	479	-
		Lo PR	109	116	127	-	115	123	134	-	120	127	139	-	126	134	146	-	132	140	153	-	136	145	158	-
		MBh	39.0	40.4	44.3	-	38.1	39.5	43.3	-	37.2	38.5	42.2	-	36.3	37.6	41.2	-	34.5	35.7	39.1	-	31.9	33.1	36.3	-
		S/T	0.70	0.58	0.40	-	0.72	0.60	0.42	-	0.74	0.62	0.43	-	0.77	0.64	0.44	-	0.80	0.66	0.46	-	0.80	0.67	0.46	-
		ΔT	19	17	13	-	20	17	13	-	20	17	13	-	20	17	13	-	19	17	13	-	18	16	12	-
1150	KW	2.63	2.69	2.78	-	2.84	2.90	3.00	-	3.02	3.09	3.19	-	3.19	3.26	3.37	-	3.32	3.40	3.51	-	3.44	3.52	3.64	-	
	Amps	11.4	11.7	12.0	-	12.2	12.5	12.9	-	13.2	13.5	13.9	-	14.0	14.3	14.7	-	14.8	15.1	15.6	-	15.6	15.9	16.4	-	
	Hi PR	232	249	263	-	260	280	296	-	296	318	336	-	337	363	383	-	379	408	431	-	419	451	476	-	
	Lo PR	108	115	126	-	114	122	133	-	119	126	138	-	125	133	145	-	131	139	152	-	135	144	157	-	
	MBh	37.1	38.4	42.1	-	36.2	37.5	41.1	-	35.3	36.6	40.1	-	34.5	35.7	39.1	-	32.7	33.9	37.2	-	30.3	31.4	34.4	-	

IDB	AIRFLOW	OUTDOOR AMBIENT TEMPERATURE																								
		65°F				75°F				85°F				95°F				105°F				115°F				
		59	63	67	71	59	63	67	71	59	63	67	71	59	63	67	71	59	63	67	71	59	63	67	71	
75	1450	MBh	40.3	41.5	44.9	48.2	39.3	40.5	43.8	47.0	38.4	39.5	42.8	45.9	37.5	38.6	41.7	44.8	35.6	36.6	39.7	42.6	33.0	33.9	36.7	39.4
		S/T	0.83	0.74	0.56	0.36	0.86	0.77	0.58	0.37	0.88	0.79	0.60	0.38	0.91	0.81	0.62	0.40	0.94	0.84	0.64	0.41	0.95	0.85	0.64	0.41
		ΔT	21	20	16	11	21	20	16	11	21	20	16	11	22	20	16	11	21	20	16	11	20	18	15	10
		KW	2.67	2.73	2.82	2.91	2.88	2.95	3.04	3.14	3.07	3.14	3.24	3.35	3.23	3.31	3.42	3.53	3.37	3.45	3.57	3.69	3.49	3.57	3.69	3.82
		Amps	11.6	11.8	12.2	12.6	12.4	12.7	13.0	13.5	13.4	13.7	14.1	14.5	14.2	14.5	14.9	15.4	15.0	15.3	15.8	16.4	15.8	16.2	16.7	17.2
	1300	Hi PR	236	254	268	279	265	285	301	314	301	324	342	357	343	369	389	406	386	415	438	457	426	458	484	505
		Lo PR	110	117	128	136	116	124	135	144	121	129	140	150	127	135	147	157	133	142	155	165	138	146	160	170
		MBh	39.7	40.8	44.2	47.4	38.7	39.9	43.2	46.3	37.8	38.9	42.2	45.2	36.9	38.0	41.1	44.1	35.1	36.1	39.1	41.9	32.5	33.4	36.2	38.8
		S/T	0.79	0.71	0.54	0.35	0.82	0.74	0.56	0.36	0.84	0.76	0.57	0.37	0.87	0.78	0.59	0.38	0.90	0.81	0.61	0.39	0.91	0.82	0.62	0.40
		ΔT	22	21	17	12	23	21	17	12	23	21	17	12	23	21	17	12	22	21	17	12	21	19	16	11
1150	KW	2.66	2.71	2.80	2.89	2.87	2.93	3.03	3.13	3.05	3.12	3.22	3.33	3.21	3.29	3.40	3.51	3.35	3.43	3.54	3.67	3.47	3.55	3.67	3.80	
	Amps	11.5	11.8	12.1	12.5	12.3	12.6	13.0	13.4	13.3	13.6	14.0	14.5	14.1	14.4	14.8	15.4	14.9	15.2	15.7	16.3	15.7	16.1	16.6	17.1	
	Hi PR	234	252	266	278	263	283	299	311	299	322	340	354	340	366	387	403	383	412	435	454	423	455	481	501	
	Lo PR	109	116	127	135	116	123	134	143	120	128	139	149	126	134	146	156	132	141	154	163	137	145	159	169	
	MBh	37.7	38.8	42.0	45.1	36.8	37.9	41.0	44.0	35.9	37.0	40.0	43.0	35.1	36.1	39.1	41.9	33.3	34.3	37.1	39.8	30.8	31.8	34.4	36.9	

IDB: Entering Indoor Dry Bulb Temperature
 High and low pressures are measured at the liquid and suction service valves.
 Design Subcooling, 10 ± 2 °F @ the liquid access fitting connection AHR195 test conditions. Design Superheat 15 ± 2°F @ the compressor suction access fitting connection.
 Shaded area reflects ACCA (TVA) conditions.
 kW = Total system power
 Amps = outdoor unit amps (comp.+fan)

IDB	AIRFLOW	OUTDOOR AMBIENT TEMPERATURE												ENTERING INDOOR WET BULB TEMPERATURE												
		65°F				75°F				85°F				95°F				105°F				115°F				
		59	63	67	71	59	63	67	71	59	63	67	71	59	63	67	71	59	63	67	71	59	63	67	71	
80	MBh	41.0	41.9	44.7	47.8	40.0	40.9	43.7	46.7	39.1	39.9	42.7	45.6	38.1	39.0	41.6	44.5	36.2	37.0	39.5	42.3	33.5	34.3	36.6	39.1	
	S/T	0.91	0.85	0.69	0.52	0.94	0.88	0.72	0.54	0.97	0.91	0.74	0.55	1.00	0.94	0.76	0.57	1.00	0.97	0.79	0.59	1.00	0.98	0.80	0.60	
	ΔT	24	23	20	16	24	23	20	16	24	23	20	16	24	23	20	16	23	23	20	16	21	21	19	15	
	kW	2.69	2.75	2.84	2.94	2.91	2.97	3.07	3.17	3.09	3.16	3.27	3.38	3.26	3.33	3.45	3.56	3.40	3.48	3.60	3.72	3.52	3.60	3.73	3.86	
	Amps	11.7	11.9	12.3	12.7	12.5	12.8	13.2	13.6	13.5	13.8	14.2	14.7	14.3	14.6	15.1	15.6	15.1	15.5	15.9	16.5	15.9	16.3	16.8	17.4	
	Hi PR	238	256	271	282	267	288	304	317	304	327	345	360	346	373	393	410	389	419	443	462	430	463	489	510	
	Lo PR	111	118	129	138	118	125	136	145	122	130	142	151	128	136	149	159	134	143	156	166	139	148	162	172	
	MBh	40.4	41.3	44.1	47.1	39.4	40.3	43.1	46.0	38.5	39.3	42.0	44.9	37.6	38.4	41.0	43.8	35.7	36.5	39.0	41.6	33.0	33.8	36.1	38.6	
	S/T	0.87	0.82	0.67	0.50	0.90	0.85	0.69	0.52	0.93	0.87	0.71	0.53	0.96	0.90	0.73	0.55	0.99	0.93	0.76	0.57	1.00	0.94	0.76	0.57	
	ΔT	25	24	21	17	25	24	21	17	25	24	21	17	25	24	21	17	25	24	21	17	23	22	19	16	
kW	2.68	2.74	2.83	2.92	2.89	2.95	3.05	3.15	3.08	3.15	3.25	3.36	3.24	3.31	3.43	3.54	3.38	3.46	3.58	3.70	3.50	3.58	3.70	3.83		
Amps	11.6	11.9	12.2	12.6	12.4	12.7	13.1	13.5	13.4	13.7	14.1	14.6	14.2	14.5	15.0	15.5	15.0	15.4	15.8	16.4	15.9	16.2	16.7	17.3		
Hi PR	237	255	269	280	265	286	302	315	302	325	343	358	344	370	391	407	387	416	439	458	427	460	486	506		
Lo PR	110	117	128	137	117	124	136	144	121	129	141	150	127	136	148	158	133	142	155	165	138	147	160	171		
1150	MBh	38.4	39.2	41.9	44.8	37.5	38.3	40.9	43.7	36.6	37.4	39.9	42.7	35.7	36.5	39.0	41.6	33.9	34.6	37.0	39.6	31.4	32.1	34.3	36.6	
	S/T	0.83	0.78	0.64	0.48	0.86	0.81	0.66	0.49	0.89	0.83	0.68	0.51	0.92	0.86	0.70	0.52	0.95	0.89	0.73	0.54	0.96	0.90	0.73	0.55	
	ΔT	26	25	21	17	26	25	22	17	26	25	22	17	26	25	22	17	26	25	21	17	24	23	20	16	
	kW	2.63	2.69	2.78	2.87	2.84	2.90	3.00	3.10	3.02	3.09	3.19	3.30	3.19	3.26	3.37	3.48	3.32	3.40	3.51	3.63	3.44	3.52	3.64	3.77	
	Amps	11.4	11.7	12.0	12.4	12.2	12.5	12.9	13.3	13.2	13.5	13.9	14.3	14.0	14.3	14.7	15.2	14.8	15.1	15.6	16.1	15.6	15.9	16.4	17.0	
	Hi PR	232	249	263	275	260	280	296	308	296	318	336	351	337	363	383	399	379	408	431	449	419	451	476	496	
	Lo PR	108	115	126	134	114	122	133	141	119	126	138	147	125	133	145	154	131	139	152	162	135	144	157	167	
	1450	MBh	41.7	42.5	44.5	47.5	40.7	41.5	43.5	46.4	39.8	40.5	42.4	45.3	38.8	39.5	41.4	44.2	36.8	37.6	39.3	42.0	34.1	34.8	36.4	38.9
		S/T	0.95	0.92	0.83	0.67	0.99	0.95	0.86	0.70	1.00	0.98	0.88	0.72	1.00	0.94	0.81	0.65	1.00	0.96	0.83	0.67	1.00	0.96	0.81	0.65
		ΔT	25	25	23	20	26	25	24	21	25	25	24	21	25	25	24	21	23	24	24	20	22	22	22	19
kW		2.72	2.77	2.86	2.96	2.93	3.00	3.09	3.20	3.12	3.19	3.30	3.41	3.29	3.36	3.48	3.60	3.43	3.51	3.63	3.75	3.55	3.64	3.76	3.89	
Amps		11.8	12.0	12.4	12.8	12.6	12.9	13.3	13.7	13.6	13.9	14.3	14.8	14.4	14.7	15.2	15.7	15.3	15.6	16.1	16.6	16.1	16.4	17.0	17.5	
Hi PR		241	259	273	285	270	290	307	320	307	330	349	364	350	376	397	414	393	423	447	466	435	468	494	515	
Lo PR		112	120	130	139	119	126	138	147	123	131	143	153	130	138	150	160	136	144	158	168	140	149	163	174	
85		MBh	41.1	41.9	43.9	46.8	40.1	40.9	42.8	45.7	39.2	39.9	41.8	44.6	38.2	39.0	40.8	43.5	36.3	37.0	38.8	41.3	33.6	34.3	35.9	38.3
		S/T	0.91	0.88	0.80	0.65	0.95	0.91	0.82	0.67	0.97	0.94	0.85	0.69	1.00	0.97	0.87	0.71	1.00	0.96	0.87	0.70	1.00	0.96	0.87	0.71
		ΔT	27	26	25	21	27	26	25	22	27	26	25	22	27	27	25	22	26	26	25	21	24	24	23	20
	kW	2.70	2.76	2.85	2.94	2.91	2.98	3.08	3.18	3.10	3.17	3.28	3.39	3.27	3.34	3.46	3.57	3.41	3.49	3.61	3.73	3.53	3.61	3.74	3.87	
	Amps	11.7	12.0	12.3	12.7	12.5	12.8	13.2	13.6	13.5	13.8	14.2	14.7	14.3	14.7	15.1	15.6	15.2	15.5	16.0	16.5	16.0	16.3	16.9	17.4	
	Hi PR	239	257	271	283	268	288	305	318	305	328	346	361	347	374	395	412	391	420	444	463	432	464	490	512	
	Lo PR	112	119	130	138	118	125	137	146	122	130	142	152	129	137	149	159	135	143	157	167	139	148	162	173	
	1150	MBh	39.0	39.8	41.7	44.4	38.1	38.9	40.7	43.4	37.2	37.9	39.7	42.4	36.3	37.0	38.8	41.3	34.5	35.2	36.8	39.3	31.9	32.6	34.1	36.4
		S/T	0.87	0.84	0.76	0.62	0.91	0.87	0.79	0.64	0.93	0.90	0.81	0.66	0.96	0.93	0.84	0.68	1.00	0.96	0.87	0.70	1.00	0.97	0.87	0.71
		ΔT	27	27	25	22	28	27	26	22	28	27	26	22	28	27	26	22	27	27	26	22	26	25	24	21
kW		2.66	2.71	2.80	2.89	2.87	2.93	3.02	3.13	3.05	3.12	3.22	3.33	3.21	3.29	3.40	3.51	3.35	3.43	3.54	3.67	3.47	3.55	3.67	3.80	
Amps		11.5	11.8	12.1	12.5	12.3	12.6	13.0	13.4	13.3	13.6	14.0	14.4	14.1	14.4	14.8	15.4	14.9	15.2	15.7	16.3	15.7	16.1	16.6	17.1	
Hi PR		234	252	266	277	263	283	299	311	299	321	339	354	340	366	387	403	383	412	435	454	423	455	481	501	
Lo PR		109	116	127	135	115	123	134	143	120	128	139	148	126	134	146	156	132	141	153	163	137	145	159	169	

IDB: Entering Indoor Dry Bulb Temperature
 High and low pressures are measured at the liquid and suction service valves.
 Design Subcooling, 10 ± 2 °F @ the liquid access fitting connection AHR195 test conditions. Design Superheat, 15 ± 2 °F @ the compressor suction access fitting connection.
 Shaded area reflects AHR1 conditions.
 kW = Total system power
 Amps = outdoor unit amps (comp.+fan)

IDB	AIRFLOW	OUTDOOR AMBIENT TEMPERATURE												105°F												115°F											
		65°F						75°F						85°F						95°F						105°F						115°F					
		59	63	67	71	59	63	67	71	59	63	67	71	59	63	67	71	59	63	67	71	59	63	67	71	59	63	67	71	59	63	67	71				
70	1800	MBh	46.1	47.7	52.3	-	45.0	46.6	51.1	-	43.9	45.5	49.9	-	42.8	44.4	48.7	-	40.7	42.2	46.2	-	37.7	39.1	42.8	-	40.7	42.2	46.2	-	37.7	39.1	42.8	-			
		S/T	0.77	0.64	0.44	-	0.79	0.66	0.46	-	0.81	0.68	0.47	-	0.84	0.70	0.49	-	0.87	0.73	0.51	-	0.88	0.74	0.51	-	0.87	0.73	0.51	-	0.88	0.74	0.51	-			
		ΔT	18	16	12	-	18	16	12	-	18	16	12	-	18	16	12	-	18	16	12	-	17	15	11	-	18	16	12	-	17	15	11	-			
		kW	3.16	3.23	3.33	-	3.40	3.48	3.59	-	3.62	3.70	3.82	-	3.81	3.89	4.02	-	3.97	4.06	4.19	-	4.11	4.20	4.34	-	3.97	4.06	4.19	-	4.11	4.20	4.34	-			
		Amps	13.7	14.0	14.4	-	14.7	15.0	15.5	-	15.9	16.2	16.7	-	16.9	17.2	17.8	-	17.9	18.3	18.8	-	18.8	19.3	19.9	-	17.9	18.3	18.8	-	18.8	19.3	19.9	-			
		Hi/PR	246	265	280	-	276	297	314	-	314	338	357	-	358	385	407	-	403	433	458	-	445	479	505	-	403	433	458	-	445	479	505	-			
	Lo/PR	112	119	130	-	118	126	138	-	123	131	143	-	129	138	150	-	136	144	157	-	140	149	163	-	136	144	157	-	140	149	163	-				
	1600	MBh	44.7	46.3	50.8	-	43.7	45.3	49.6	-	42.6	44.2	48.4	-	41.6	43.1	47.2	-	39.5	41.0	44.9	-	36.6	37.9	41.6	-	39.5	41.0	44.9	-	36.6	37.9	41.6	-			
		S/T	0.73	0.61	0.42	-	0.76	0.63	0.44	-	0.78	0.65	0.45	-	0.80	0.67	0.46	-	0.83	0.70	0.48	-	0.84	0.70	0.49	-	0.83	0.70	0.48	-	0.84	0.70	0.49	-			
		ΔT	19	16	12	-	19	16	12	-	19	16	13	-	19	17	13	-	19	16	12	-	18	15	12	-	19	16	12	-	18	15	12	-			
		kW	3.13	3.20	3.30	-	3.38	3.45	3.56	-	3.59	3.67	3.79	-	3.78	3.86	3.99	-	3.94	4.02	4.16	-	4.07	4.17	4.30	-	3.94	4.02	4.16	-	4.07	4.17	4.30	-			
		Amps	13.6	13.9	14.3	-	14.6	14.9	15.4	-	15.7	16.1	16.6	-	16.7	17.1	17.6	-	17.7	18.1	18.7	-	18.7	19.1	19.7	-	17.7	18.1	18.7	-	18.7	19.1	19.7	-			
Hi/PR		244	262	277	-	274	294	311	-	311	335	354	-	354	381	403	-	399	429	453	-	440	474	500	-	399	429	453	-	440	474	500	-				
Lo/PR	111	118	129	-	117	125	136	-	122	130	142	-	128	136	149	-	134	143	156	-	139	148	161	-	134	143	156	-	139	148	161	-					
1420	MBh	42.5	44.0	48.2	-	41.5	43.0	47.1	-	40.5	42.0	46.0	-	39.5	41.0	44.9	-	37.5	38.9	42.6	-	34.8	36.0	39.5	-	37.5	38.9	42.6	-	34.8	36.0	39.5	-				
	S/T	0.70	0.59	0.41	-	0.73	0.61	0.42	-	0.74	0.62	0.43	-	0.77	0.64	0.44	-	0.80	0.67	0.46	-	0.80	0.67	0.47	-	0.80	0.67	0.46	-	0.80	0.67	0.47	-				
	ΔT	19	17	13	-	20	17	13	-	20	17	13	-	20	17	13	-	20	17	13	-	18	16	12	-	20	17	13	-	18	16	12	-				
	kW	3.08	3.15	3.25	-	3.32	3.39	3.50	-	3.53	3.61	3.72	-	3.71	3.80	3.92	-	3.87	3.96	4.09	-	4.01	4.09	4.23	-	3.87	3.96	4.09	-	4.01	4.09	4.23	-				
	Amps	13.4	13.7	14.1	-	14.4	14.7	15.1	-	15.5	15.8	16.3	-	16.4	16.8	17.3	-	17.4	17.8	18.3	-	18.4	18.8	19.4	-	17.4	17.8	18.3	-	18.4	18.8	19.4	-				
	Hi/PR	239	257	271	-	268	288	305	-	305	328	346	-	347	374	395	-	391	420	444	-	432	464	490	-	391	420	444	-	432	464	490	-				
Lo/PR	109	116	126	-	115	122	133	-	119	127	139	-	125	133	146	-	131	140	153	-	136	145	158	-	131	140	153	-	136	145	158	-					

IDB	AIRFLOW	OUTDOOR AMBIENT TEMPERATURE												105°F												115°F											
		65°F						75°F						85°F						95°F						105°F						115°F					
		59	63	67	71	59	63	67	71	59	63	67	71	59	63	67	71	59	63	67	71	59	63	67	71	59	63	67	71	59	63	67	71				
75	1800	MBh	46.8	48.2	52.2	56.0	45.7	47.1	51.0	54.7	44.7	46.0	49.8	53.4	43.6	44.9	48.6	52.1	41.4	42.6	46.1	49.5	38.3	39.5	42.7	45.9	41.4	42.6	46.1	49.5	38.3	39.5	42.7	45.9			
		S/T	0.87	0.78	0.59	0.38	0.90	0.81	0.61	0.39	0.93	0.83	0.63	0.40	0.96	0.86	0.65	0.42	0.99	0.89	0.67	0.43	1.00	0.90	0.68	0.44	0.99	0.89	0.67	0.43	1.00	0.90	0.68	0.44			
		ΔT	21	19	16	11	21	19	16	11	21	19	16	11	21	20	16	11	21	19	16	11	20	18	15	10	21	19	16	11	20	18	15	10			
		kW	3.19	3.25	3.36	3.46	3.43	3.51	3.62	3.74	3.65	3.73	3.85	3.98	3.84	3.93	4.05	4.19	4.00	4.09	4.23	4.37	4.14	4.24	4.38	4.53	4.00	4.09	4.23	4.37	4.14	4.24	4.38	4.53			
		Amps	13.8	14.1	14.5	15.0	14.8	15.2	15.6	16.1	16.0	16.4	16.9	17.4	17.0	17.4	17.9	18.5	18.0	18.4	19.0	19.7	19.0	19.4	20.0	20.8	18.0	18.4	19.0	19.7	19.0	19.4	20.0	20.8			
		Hi/PR	249	268	283	295	279	300	317	331	317	342	361	376	362	389	411	428	407	438	462	482	449	484	511	533	407	438	462	482	449	484	511	533			
	Lo/PR	113	120	132	140	120	127	139	148	124	132	144	154	131	139	152	162	137	146	159	169	142	151	164	175	137	146	159	169	142	151	164	175				
	1600	MBh	45.5	46.8	50.7	54.4	44.4	45.7	49.5	53.1	43.4	44.6	48.3	51.9	42.3	43.6	47.1	50.6	40.2	41.4	44.8	48.1	37.2	38.3	41.5	44.5	40.2	41.4	44.8	48.1	37.2	38.3	41.5	44.5			
		S/T	0.83	0.74	0.56	0.36	0.86	0.77	0.58	0.38	0.88	0.79	0.60	0.38	0.91	0.82	0.62	0.40	0.95	0.85	0.64	0.41	0.95	0.85	0.65	0.42	0.95	0.85	0.64	0.41	0.95	0.85	0.65	0.42			
		ΔT	22	20	16	11	22	20	17	11	22	20	17	11	22	20	17	12	22	20	16	11	20	19	15	11	22	20	16	11	20	19	15	11			
		kW	3.16	3.23	3.33	3.44	3.40	3.48	3.59	3.71	3.62	3.70	3.82	3.95	3.81	3.89	4.02	4.16	3.97	4.06	4.19	4.33	4.11	4.20	4.34	4.49	3.97	4.06	4.19	4.33	4.11	4.20	4.34	4.49			
		Amps	13.7	14.0	14.4	14.9	14.7	15.0	15.5	16.0	15.9	16.2	16.7	17.3	16.9	17.2	17.8	18.4	17.9	18.3	18.8	19.5	18.8	19.3	19.9	20.6	17.9	18.3	18.8	19.5	18.8	19.3	19.9	20.6			
Hi/PR		246	265	280	292	276	297	314	328	314	338	357	372	358	385	407	424	403	433	458	477	445	479	506	527	403	433	458	477	445	479	506	527				
Lo/PR	112	119	130	139	118	126	138	147	123	131	143	152	129	138	150	160	136	144	157	168	140	149	163	173	136	144	157	168	140	149	163	173					
1420	MBh	43.2	44.5	48.1	51.7	42.2	43.4	47.0	50.5	41.2	42.4	45.9	49.3	40.2	41.4	44.8	48.1	38.2	39.3	42.5	45.7	35.4	36.4	39.4	42.3	38.2	39.3	42.5	45.7	35.4	36.4	39.4	42.3				
	S/T	0.80	0.71	0.54	0.35	0.83	0.74	0.56	0.36	0.85	0.76	0.57	0.37	0.87	0.78	0.59	0.38	0.91	0.81	0.61	0.39	0.91	0.82	0.62	0.40	0.91	0.81	0.61	0.39	0.91	0.82	0.62	0.40				
	ΔT	22	21	17	12	23	21	17	12	23	21	17	12	23	21	17	12	23	21	17	12	21	19	16	11	23	21	17	12	21	19	16	11				
	kW	3.11	3.18	3.28	3.38	3.35	3.42	3.53	3.65	3.56	3.64	3.75	3.88	3.74	3.83	3.95	4.09	3.90	3.99	4.12	4.26	4.04	4.13	4.27	4.41	3.90	3.99	4.12	4.26	4.04	4.13	4.27	4.41				
	Amps	13.5	13.8	14.2	14.7	14.5	14.8	15.2	15.7	15.6	15.9	16.4	17.0	16.6	17.0	17.5	18.1	17.6	18.0	18.5	19.2	18.5	18.9	19.5	20.2	17.6	18.0	18.5	19.2	18.5	18.9	19.5	20.2				
	Hi/PR	241	260	274	286	271	291	308	321	308	331	350	365	351	377	399	416	395	425	448	468	436	469</														

IDB	AIRFLOW	OUTDOOR AMBIENT TEMPERATURE												115°F																																																																																																																																																																																																																																																																																																																																																																																																																																																																																																																																																																																																																																																																																																																																																																																																																																																																																																																																																																																																																																																																																																																																	
		65°F						75°F						85°F						95°F						105°F						115°F																																																																																																																																																																																																																																																																																																																																																																																																																																																																																																																																																																																																																																																																																																																																																																																																																																																																																																																																																																																																																																																																																																															
		59	63	67	71	75	79	59	63	67	71	75	79	59	63	67	71	75	79	59	63	67	71	75	79	59	63	67	71	75	79	59	63	67	71	75	79																																																																																																																																																																																																																																																																																																																																																																																																																																																																																																																																																																																																																																																																																																																																																																																																																																																																																																																																																																																																																																																																																																										
80	1800	MBh	47.7	48.7	52.0	55.6	59.2	62.8	66.4	70.0	73.6	77.2	80.8	84.4	88.0	91.6	95.2	98.8	102.4	106.0	109.6	113.2	116.8	120.4	124.0	127.6	131.2	134.8	138.4	142.0	145.6	149.2	152.8	156.4	160.0	163.6	167.2	170.8	174.4	178.0	181.6	185.2	188.8	192.4	196.0	199.6	203.2	206.8	210.4	214.0	217.6	221.2	224.8	228.4	232.0	235.6	239.2	242.8	246.4	250.0	253.6	257.2	260.8	264.4	268.0	271.6	275.2	278.8	282.4	286.0	289.6	293.2	296.8	300.4	304.0	307.6	311.2	314.8	318.4	322.0	325.6	329.2	332.8	336.4	340.0	343.6	347.2	350.8	354.4	358.0	361.6	365.2	368.8	372.4	376.0	379.6	383.2	386.8	390.4	394.0	397.6	401.2	404.8	408.4	412.0	415.6	419.2	422.8	426.4	430.0	433.6	437.2	440.8	444.4	448.0	451.6	455.2	458.8	462.4	466.0	469.6	473.2	476.8	480.4	484.0	487.6	491.2	494.8	498.4	502.0	505.6	509.2	512.8	516.4	520.0	523.6	527.2	530.8	534.4	538.0	541.6	545.2	548.8	552.4	556.0	559.6	563.2	566.8	570.4	574.0	577.6	581.2	584.8	588.4	592.0	595.6	599.2	602.8	606.4	610.0	613.6	617.2	620.8	624.4	628.0	631.6	635.2	638.8	642.4	646.0	649.6	653.2	656.8	660.4	664.0	667.6	671.2	674.8	678.4	682.0	685.6	689.2	692.8	696.4	700.0	703.6	707.2	710.8	714.4	718.0	721.6	725.2	728.8	732.4	736.0	739.6	743.2	746.8	750.4	754.0	757.6	761.2	764.8	768.4	772.0	775.6	779.2	782.8	786.4	790.0	793.6	797.2	800.8	804.4	808.0	811.6	815.2	818.8	822.4	826.0	829.6	833.2	836.8	840.4	844.0	847.6	851.2	854.8	858.4	862.0	865.6	869.2	872.8	876.4	880.0	883.6	887.2	890.8	894.4	898.0	901.6	905.2	908.8	912.4	916.0	919.6	923.2	926.8	930.4	934.0	937.6	941.2	944.8	948.4	952.0	955.6	959.2	962.8	966.4	970.0	973.6	977.2	980.8	984.4	988.0	991.6	995.2	998.8	1002.4	1006.0	1009.6	1013.2	1016.8	1020.4	1024.0	1027.6	1031.2	1034.8	1038.4	1042.0	1045.6	1049.2	1052.8	1056.4	1060.0	1063.6	1067.2	1070.8	1074.4	1078.0	1081.6	1085.2	1088.8	1092.4	1096.0	1099.6	1103.2	1106.8	1110.4	1114.0	1117.6	1121.2	1124.8	1128.4	1132.0	1135.6	1139.2	1142.8	1146.4	1150.0	1153.6	1157.2	1160.8	1164.4	1168.0	1171.6	1175.2	1178.8	1182.4	1186.0	1189.6	1193.2	1196.8	1200.4	1204.0	1207.6	1211.2	1214.8	1218.4	1222.0	1225.6	1229.2	1232.8	1236.4	1240.0	1243.6	1247.2	1250.8	1254.4	1258.0	1261.6	1265.2	1268.8	1272.4	1276.0	1279.6	1283.2	1286.8	1290.4	1294.0	1297.6	1301.2	1304.8	1308.4	1312.0	1315.6	1319.2	1322.8	1326.4	1330.0	1333.6	1337.2	1340.8	1344.4	1348.0	1351.6	1355.2	1358.8	1362.4	1366.0	1369.6	1373.2	1376.8	1380.4	1384.0	1387.6	1391.2	1394.8	1398.4	1402.0	1405.6	1409.2	1412.8	1416.4	1420.0	1423.6	1427.2	1430.8	1434.4	1438.0	1441.6	1445.2	1448.8	1452.4	1456.0	1459.6	1463.2	1466.8	1470.4	1474.0	1477.6	1481.2	1484.8	1488.4	1492.0	1495.6	1499.2	1502.8	1506.4	1510.0	1513.6	1517.2	1520.8	1524.4	1528.0	1531.6	1535.2	1538.8	1542.4	1546.0	1549.6	1553.2	1556.8	1560.4	1564.0	1567.6	1571.2	1574.8	1578.4	1582.0	1585.6	1589.2	1592.8	1596.4	1600.0	1603.6	1607.2	1610.8	1614.4	1618.0	1621.6	1625.2	1628.8	1632.4	1636.0	1639.6	1643.2	1646.8	1650.4	1654.0	1657.6	1661.2	1664.8	1668.4	1672.0	1675.6	1679.2	1682.8	1686.4	1690.0	1693.6	1697.2	1700.8	1704.4	1708.0	1711.6	1715.2	1718.8	1722.4	1726.0	1729.6	1733.2	1736.8	1740.4	1744.0	1747.6	1751.2	1754.8	1758.4	1762.0	1765.6	1769.2	1772.8	1776.4	1780.0	1783.6	1787.2	1790.8	1794.4	1798.0	1801.6	1805.2	1808.8	1812.4	1816.0	1819.6	1823.2	1826.8	1830.4	1834.0	1837.6	1841.2	1844.8	1848.4	1852.0	1855.6	1859.2	1862.8	1866.4	1870.0	1873.6	1877.2	1880.8	1884.4	1888.0	1891.6	1895.2	1898.8	1902.4	1906.0	1909.6	1913.2	1916.8	1920.4	1924.0	1927.6	1931.2	1934.8	1938.4	1942.0	1945.6	1949.2	1952.8	1956.4	1960.0	1963.6	1967.2	1970.8	1974.4	1978.0	1981.6	1985.2	1988.8	1992.4	1996.0	1999.6	2003.2	2006.8	2010.4	2014.0	2017.6	2021.2	2024.8	2028.4	2032.0	2035.6	2039.2	2042.8	2046.4	2050.0	2053.6	2057.2	2060.8	2064.4	2068.0	2071.6	2075.2	2078.8	2082.4	2086.0	2089.6	2093.2	2096.8	2100.4	2104.0	2107.6	2111.2	2114.8	2118.4	2122.0	2125.6	2129.2	2132.8	2136.4	2140.0	2143.6	2147.2	2150.8	2154.4	2158.0	2161.6	2165.2	2168.8	2172.4	2176.0	2179.6	2183.2	2186.8	2190.4	2194.0	2197.6	2201.2	2204.8	2208.4	2212.0	2215.6	2219.2	2222.8	2226.4	2230.0	2233.6	2237.2	2240.8	2244.4	2248.0	2251.6	2255.2	2258.8	2262.4	2266.0	2269.6	2273.2	2276.8	2280.4	2284.0	2287.6	2291.2	2294.8	2298.4	2302.0	2305.6	2309.2	2312.8	2316.4	2320.0	2323.6	2327.2	2330.8	2334.4	2338.0	2341.6	2345.2	2348.8	2352.4	2356.0	2359.6	2363.2	2366.8	2370.4	2374.0	2377.6	2381.2	2384.8	2388.4	2392.0	2395.6	2399.2	2402.8	2406.4	2410.0	2413.6	2417.2	2420.8	2424.4	2428.0	2431.6	2435.2	2438.8	2442.4	2446.0	2449.6	2453.2	2456.8	2460.4	2464.0	2467.6	2471.2	2474.8	2478.4	2482.0	2485.6	2489.2	2492.8	2496.4	2500.0	2503.6	2507.2	2510.8	2514.4	2518.0	2521.6	2525.2	2528.8	2532.4	2536.0	2539.6	2543.2	2546.8	2550.4	2554.0	2557.6	2561.2	2564.8	2568.4	2572.0	2575.6	2579.2	2582.8	2586.4	2590.0	2593.6	2597.2	2600.8	2604.4	2608.0	2611.6	2615.2	2618.8	2622.4	2626.0	2629.6	2633.2	2636.8	2640.4	2644.0	2647.6	2651.2	2654.8	2658.4	2662.0	2665.6	2669.2	2672.8	2676.4	2680.0	2683.6	2687.2	2690.8	2694.4	2698.0	2701.6	2705.2	2708.8	2712.4	2716.0	2719.6	2723.2	2726.8	2730.4	2734.0	2737.6	2741.2	2744.8	2748.4	2752.0	2755.6	2759.2	2762.8	2766.4	2770.0	2773.6	2777.2	2780.8	2784.4	2788.0	2791.6	2795.2	2798.8	2802.4	2806.0	2809.6	2813.2	2816.8	2820.4	2824.0	2827.6	2831.2	2834.8	2838.4	2842.0	2845.6	2849.2	2852.8	2856.4	2860.0	2863.6	2867.2	2870.8	2874.4	2878.0	2881.6	2885.2	2888.8	2892.4	2896.0	2899.6	2903.2	2906.8	2910.4	2914.0	2917.6	2921.2	2924.8	2928.4	2932.0	2935.6	2939.2	2942.8	2946.4	2950.0	2953.6	2957.2	2960.8	2964.4	2968.0	2971.6	2975.2	2978.8	2982.4	2986.0	2989.6	2993.2	2996.8	3000.4	3004.0	3007.6	3011.2	3014.8	3018.4	3022.0	3025.6	3029.2	3032.8	3036.4	3040.0	3043.6	3047.2	3050.8	3054.4	3058.0	3061.6	3065.2	3068.8	3072.4	3076.0	3079.6	3083.2	3086.8	3090.4	3094.0	3097.6	3101.2	3104.8	3108.4	3112.0	3115.6	3119.2	3122.8	3126.4	3130.0	3133.6	3137.2	3140.8	3144.4	3148.0	3151.6	3155.2	3158.8	3162.4	3166.0	3169.6	3173.2	3176.8	3180.4	3184.0	3187.6	3191.2	3194.8	3198.4	3202.0	3205.6	3209.2	3212.8	3216.4	3220.0	3223.6	3227.2	3230.8	3234.4	3238.0	3241.6	3245.2	3248.8	3252.4	3256.0	3259.6	3263.2	3266.8	3270.4	3274.0	3277.6	3281.2	3284.8	3288.4	3292.0	3295.6	3299.2	3302.8	3306.4	3310.0	3313.6	3317.2	3320.8	3324.4	3328.0	3331.6	3335.2	3338.8	3342.4	3346.0	3349.6	3353.2	3356.8	3360.4	3364.0	3367.6	3371.2	3374.8	3378.4	3382.0	3385.6	3389.2	3392.8	3396.4	3400.0	3403.6	3407.2	3410.8	3414.4	3418.0	3421.6	3425.2	3428.8	3432.4	3436.0	3439.6	3443.2	3446.8	3450.4	3454.0	3457.6	3461.2	3464.8	3468.4	3472.0	3475.6	3479.2	3482.8	3486.4	3490.0	3493.6	3497.2	3500.8	3504.4	3508.0	3511.6	3515.2	3518.8	3522.4	3526.0	3529.6	3533.2	3536.8	3540.4	3544.0	3547.6	3551.2	3554.8	3558.4	3562.0	3565.6	3569.2	3572.8	3576.4	3580.0	3583.6	3587.2	3590.8	3594.4	3598.0	3601.6	3605.2	3608.8	3612.4	3616.0	3619.6	3623.2	3626.8	3630.4	3634.0	3637.6	3641.2	3644.8	3648.4	3652.0	3655.6	3659.2	3662.8	3666.4	3670.0	3673.6	3677.2	3680.8	3684.4	3688.0	3691.6	3695.2	3698.8	3702.4	3706.0	3709.6	3713.2	3716.8	3720.4	3724.0	3727.6	3731.2	3734.8	3738.4	3742.0	3745.6	3749.2	3752.8	3756.4	3760.0	3763.6	3767.2	3770.8	3774.4	3778.0	3781.6	3785.2	3788.8	3792.4	3796.0	3799.6	3803.2	3806.8	3810.4	3814.0	3817.6	3821.2	3824.8	3828.4	3832.0	3835.6	3839.2	3842.8	3846.4	3850.0	3853.6	3857.2	3860.8	3864.4	3868.0	3871.6	3875.2	3878.8	3882.4	3886.0	3889.6	3893.2	3896.8	3900.4	3904.0	3907.6	3911.2	3914.8	3918.4	3922.0	3925.6	3929.2	3932.8	3936.4	3940.0	3943.6	3947.2	3950.8	3954.4	3958.0	3961.6	3965.2	3968.8	3972.4	3976.0	3979.6	3983.2	3986.8	3990.4	3994.0	3997.6	4001.2	4004.8

IDB	AIRFLOW	OUTDOOR AMBIENT TEMPERATURE												ENTERING INDOOR WET BULB TEMPERATURE											
		65°F				75°F				85°F				95°F				105°F				115°F			
		59	63	67	71	59	63	67	71	59	63	67	71	59	63	67	71	59	63	67	71	59	63	67	71
70	MBh	57.5	59.6	65.3	-	56.2	58.2	63.8	-	54.8	56.8	62.3	-	53.5	55.5	60.8	-	50.8	52.7	57.7	-	47.1	48.8	53.5	-
	S/T	0.77	0.64	0.45	-	0.80	0.67	0.46	-	0.82	0.68	0.47	-	0.85	0.71	0.49	-	0.88	0.73	0.51	-	0.88	0.74	0.51	-
	ΔT	19	16	12	-	19	16	12	-	19	16	12	-	19	16	12	-	19	16	12	-	17	15	11	-
	KW	3.82	3.89	4.01	-	4.10	4.19	4.32	-	4.35	4.44	4.58	-	4.57	4.67	4.82	-	4.76	4.86	5.02	-	4.92	5.03	5.19	-
	Amps	16.3	16.7	17.2	-	17.5	17.9	18.4	-	18.8	19.2	19.8	-	20.0	20.4	21.0	-	21.1	21.6	22.2	-	22.3	22.8	23.5	-
	Hi PR	225	242	256	-	252	272	287	-	287	309	326	-	327	352	372	-	368	396	418	-	407	438	462	-
Lo PR	111	118	129	-	118	125	137	-	122	130	142	-	128	137	149	-	135	143	156	-	139	148	162	-	
1961	MBh	55.8	57.9	63.4	-	54.5	56.5	61.9	-	53.2	55.2	60.5	-	51.9	53.8	59.0	-	49.3	51.1	56.0	-	45.7	47.4	51.9	-
	S/T	0.73	0.61	0.43	-	0.76	0.64	0.44	-	0.78	0.65	0.45	-	0.81	0.67	0.47	-	0.84	0.70	0.48	-	0.84	0.70	0.49	-
	ΔT	19	17	13	-	19	17	13	-	19	17	13	-	20	17	13	-	19	17	13	-	18	16	12	-
	KW	3.79	3.86	3.98	-	4.07	4.15	4.28	-	4.32	4.41	4.55	-	4.54	4.63	4.78	-	4.72	4.82	4.98	-	4.88	4.99	5.15	-
	Amps	16.2	16.5	17.0	-	17.3	17.7	18.2	-	18.7	19.1	19.6	-	19.8	20.2	20.8	-	21.0	21.4	22.1	-	22.1	22.6	23.3	-
	Hi PR	223	240	253	-	250	269	284	-	284	306	323	-	324	348	368	-	364	392	414	-	403	433	457	-
Lo PR	110	117	128	-	116	124	135	-	121	129	141	-	127	135	148	-	133	142	155	-	138	147	160	-	
1756	MBh	53.0	55.0	60.2	-	51.8	53.7	58.8	-	50.6	52.4	57.4	-	49.3	51.1	56.0	-	46.9	48.6	53.2	-	43.4	45.0	49.3	-
	S/T	0.70	0.59	0.41	-	0.73	0.61	0.42	-	0.75	0.62	0.43	-	0.77	0.64	0.45	-	0.80	0.67	0.46	-	0.81	0.67	0.47	-
	ΔT	20	17	13	-	20	17	13	-	20	17	13	-	20	17	13	-	20	17	13	-	19	16	12	-
	KW	3.73	3.81	3.92	-	4.00	4.09	4.21	-	4.25	4.34	4.47	-	4.46	4.56	4.70	-	4.64	4.74	4.90	-	4.80	4.91	5.07	-
	Amps	16.0	16.3	16.7	-	17.1	17.4	17.9	-	18.4	18.8	19.3	-	19.5	19.9	20.5	-	20.6	21.1	21.7	-	21.7	22.2	22.9	-
	Hi PR	218	235	248	-	245	264	278	-	279	300	317	-	317	342	361	-	357	384	406	-	394	425	448	-
Lo PR	108	115	125	-	114	121	132	-	119	126	138	-	125	132	145	-	131	139	152	-	135	144	157	-	

2201	MBh	58.5	60.2	65.2	70.0	57.1	58.8	63.7	68.3	55.8	57.4	62.1	66.7	54.4	56.0	60.6	65.1	51.7	53.2	57.6	61.8	47.9	49.3	53.4	57.3
	S/T	0.88	0.78	0.59	0.38	0.91	0.81	0.61	0.40	0.93	0.83	0.63	0.41	0.96	0.86	0.65	0.42	1.00	0.89	0.67	0.43	1.00	0.90	0.68	0.44
	ΔT	21	20	16	11	22	20	16	11	22	20	16	11	22	20	16	11	22	20	16	11	20	19	15	10
	KW	3.85	3.93	4.05	4.17	4.13	4.22	4.35	4.49	4.39	4.48	4.62	4.77	4.61	4.71	4.86	5.02	4.80	4.90	5.06	5.23	4.96	5.07	5.24	5.41
	Amps	16.5	16.8	17.3	17.9	17.6	18.0	18.5	19.1	19.0	19.4	20.0	20.6	20.1	20.6	21.2	21.9	21.3	21.8	22.4	23.2	22.5	23.0	23.7	24.5
	Hi PR	227	245	258	269	255	274	290	302	290	312	330	344	330	356	375	392	372	400	422	441	411	442	467	487
Lo PR	111	120	131	139	119	126	138	147	123	131	143	153	130	138	151	160	136	145	158	168	141	150	163	174	
1961	MBh	56.8	58.5	63.3	67.9	55.5	57.1	61.8	66.3	54.1	55.7	60.3	64.8	52.8	54.4	58.9	63.2	50.2	51.7	55.9	60.0	46.5	47.9	51.8	55.6
	S/T	0.84	0.75	0.57	0.36	0.87	0.77	0.59	0.38	0.89	0.79	0.60	0.39	0.92	0.82	0.62	0.40	0.95	0.85	0.64	0.41	0.96	0.86	0.65	0.42
	ΔT	22	20	17	12	23	21	17	12	23	21	17	12	23	21	17	12	22	21	17	12	21	19	16	11
	KW	3.82	3.90	4.01	4.14	4.10	4.19	4.32	4.45	4.35	4.44	4.58	4.73	4.57	4.67	4.82	4.98	4.76	4.86	5.02	5.19	4.92	5.03	5.19	5.37
	Amps	16.3	16.7	17.2	17.7	17.5	17.9	18.4	19.0	18.8	19.2	19.8	20.5	20.0	20.4	21.0	21.7	21.1	21.6	22.3	23.0	22.3	22.8	23.5	24.3
	Hi PR	225	242	256	267	253	272	287	299	287	309	326	340	327	352	372	388	368	396	418	436	407	438	462	482
Lo PR	111	118	129	138	118	125	137	145	122	130	142	151	128	137	149	159	135	143	156	166	139	148	162	172	
1736	MBh	53.9	55.5	60.1	64.5	52.7	54.2	58.7	63.0	51.4	53.0	57.3	61.5	50.2	51.7	55.9	60.0	47.7	49.1	53.1	57.0	44.2	45.5	49.2	52.8
	S/T	0.80	0.72	0.54	0.35	0.83	0.74	0.56	0.36	0.85	0.76	0.58	0.37	0.88	0.78	0.59	0.38	0.91	0.81	0.62	0.40	0.92	0.82	0.62	0.40
	ΔT	23	21	17	12	23	21	17	12	23	21	17	12	23	21	18	12	23	21	17	12	21	20	16	11
	KW	3.76	3.84	3.95	4.07	4.04	4.12	4.25	4.38	4.28	4.37	4.51	4.66	4.50	4.60	4.74	4.90	4.68	4.78	4.94	5.10	4.84	4.95	5.11	5.28
	Amps	16.1	16.4	16.9	17.4	17.2	17.6	18.1	18.7	18.5	18.9	19.5	20.1	19.6	20.1	20.7	21.4	20.8	21.2	21.9	22.6	21.9	22.4	23.1	23.9
	Hi PR	221	237	251	261	247	266	281	293	281	303	320	334	321	345	364	380	361	388	410	427	398	429	453	472
Lo PR	109	116	127	135	115	123	134	143	120	127	139	148	126	134	146	156	132	140	153	163	136	145	158	169	

IDB: Entering Indoor Dry Bulb Temperature
 High and low pressures are measured at the liquid and suction service valves.
 Design Subcooling, 5-7 °F @ the liquid access fitting connection AHRI 95 test conditions. Design Superheat, 15-18°F @ the compressor suction access fitting connection.
 Shaded area reflects ACCA (TVA) conditions.
 kW = Total system power
 Amps = outdoor unit amps (comp.+fan)

IDB		OUTDOOR AMBIENT TEMPERATURE																													
		65°F					75°F					85°F					95°F					105°F					115°F				
		59	63	67	71	75	59	63	67	71	75	59	63	67	71	75	59	63	67	71	75	59	63	67	71	75	59	63	67	71	75
80	2201	MBh	59.5	60.8	65.0	69.5	58.1	59.4	63.5	67.9	56.8	58.0	62.0	66.2	55.4	56.6	60.5	64.6	52.6	53.8	57.4	61.4	48.7	49.8	53.2	56.9					
		S/T	0.96	0.90	0.73	0.55	1.00	0.93	0.76	0.57	1.00	0.96	0.78	0.58	1.00	1.00	0.80	0.60	1.00	1.00	0.83	0.62	1.00	1.00	0.84	0.63					
		ΔT	24	23	20	16	24	23	20	16	24	23	20	16	23	24	20	16	22	22	20	16	20	21	19	15					
		KW	3.88	3.96	4.08	4.20	4.17	4.25	4.39	4.53	4.42	4.52	4.66	4.81	4.65	4.75	4.90	5.06	4.84	4.94	5.10	5.27	5.00	5.11	5.28	5.46					
		Amps	16.6	16.9	17.4	18.0	17.8	18.2	18.7	19.3	19.1	19.5	20.1	20.8	20.3	20.8	21.4	22.1	21.5	22.0	22.6	23.4	22.6	23.2	23.9	24.7					
	Hi PR	230	247	261	272	258	277	293	305	293	315	333	347	334	359	379	396	375	404	427	445	415	446	471	492						
	Lo PR	114	121	132	140	120	128	139	148	125	133	145	154	131	139	152	162	137	146	159	170	142	151	165	176						
	MBh	57.8	59.1	63.1	67.4	56.4	57.7	61.6	65.9	55.1	56.3	60.2	64.3	53.8	54.9	58.7	62.7	51.1	52.2	55.8	59.6	47.3	48.3	51.6	55.2						
	S/T	0.92	0.86	0.70	0.52	0.95	0.89	0.72	0.54	0.97	0.91	0.74	0.56	1.00	0.94	0.77	0.57	1.00	0.98	0.80	0.59	1.00	0.99	0.80	0.60						
	ΔT	25	24	21	17	25	24	21	17	25	24	21	17	25	24	21	17	24	24	21	17	22	22	19	16						
KW	3.85	3.93	4.05	4.17	4.13	4.22	4.35	4.49	4.39	4.48	4.62	4.77	4.61	4.71	4.86	5.02	4.80	4.90	5.06	5.23	4.96	5.07	5.24	5.41							
Amps	16.5	16.8	17.3	17.9	17.6	18.0	18.5	19.1	19.0	19.4	20.0	20.6	20.1	20.6	21.2	21.9	21.3	21.8	22.4	23.2	22.5	23.0	23.7	24.5							
Hi PR	227	245	258	269	255	275	290	302	290	312	330	344	330	356	376	392	372	400	422	441	411	442	467	487							
Lo PR	112	120	131	139	119	126	138	147	123	131	143	153	130	138	151	160	136	145	158	168	141	150	163	174							
MBh	54.9	56.1	59.9	64.1	53.6	54.8	58.5	62.6	52.4	53.5	57.2	61.1	51.1	52.2	55.8	59.6	48.5	49.6	53.0	56.6	44.9	45.9	49.1	52.5							
S/T	0.88	0.82	0.67	0.50	0.91	0.85	0.69	0.52	0.93	0.87	0.71	0.53	0.96	0.90	0.73	0.55	1.00	0.94	0.76	0.57	1.01	0.94	0.77	0.57							
ΔT	26	24	21	17	26	25	22	17	26	25	22	17	26	25	22	17	26	25	21	17	24	23	20	16							
KW	3.79	3.86	3.98	4.11	4.07	4.15	4.28	4.42	4.32	4.41	4.55	4.69	4.54	4.63	4.78	4.94	4.72	4.82	4.98	5.14	4.88	4.99	5.15	5.32							
Amps	16.2	16.5	17.0	17.6	17.3	17.7	18.2	18.8	18.7	19.1	19.6	20.3	19.8	20.2	20.8	21.6	21.0	21.4	22.1	22.8	22.1	22.6	23.3	24.1							
Hi PR	223	240	253	264	250	269	284	296	284	306	323	337	324	348	368	384	364	392	414	432	403	433	457	477							
Lo PR	110	117	128	136	116	124	135	144	121	129	141	150	127	135	148	157	133	142	155	165	138	147	160	170							
85	2201	MBh	60.6	61.7	64.7	69.0	59.2	60.3	63.2	67.4	57.7	58.9	61.7	65.8	56.3	57.4	60.1	64.2	53.5	54.6	57.1	61.0	49.6	50.5	52.9	56.5					
		S/T	1.00	0.97	0.88	0.71	1.00	1.00	0.91	0.74	1.00	1.00	0.93	0.76	1.00	1.00	0.96	0.78	1.00	1.00	0.81	0.81	1.00	1.00	0.82						
		ΔT	25	25	24	20	25	25	24	21	24	25	24	21	24	24	24	21	22	23	24	21	21	21	22	19					
		KW	3.91	3.99	4.11	4.24	4.20	4.29	4.42	4.56	4.46	4.55	4.70	4.85	4.68	4.79	4.94	5.10	4.88	4.98	5.15	5.32	5.05	5.16	5.32	5.50					
		Amps	16.7	17.1	17.6	18.1	17.9	18.3	18.8	19.5	19.3	19.7	20.3	21.0	20.5	20.9	21.6	22.3	21.7	22.1	22.8	23.6	22.8	23.3	24.1	24.9					
	Hi PR	232	250	264	275	260	280	296	308	296	318	336	351	337	363	383	400	379	408	431	449	419	451	476	497						
	Lo PR	115	122	133	142	121	129	141	150	126	134	146	156	132	141	154	164	139	147	161	171	143	153	167	177						
	MBh	58.8	59.9	62.8	67.0	57.4	58.5	61.3	65.4	56.1	57.2	59.9	63.9	54.7	55.8	58.4	62.3	52.0	53.0	55.5	59.2	48.1	49.1	51.4	54.8						
	S/T	0.96	0.93	0.84	0.68	1.00	0.96	0.87	0.70	1.00	0.98	0.89	0.72	1.00	1.00	0.92	0.74	1.00	1.00	0.95	0.77	1.00	1.00	0.96	0.78						
	ΔT	26	26	25	21	27	26	25	22	26	26	25	22	26	26	25	22	24	24	25	21	23	23	23	20						
KW	3.88	3.96	4.08	4.20	4.17	4.25	4.39	4.53	4.42	4.52	4.66	4.81	4.65	4.75	4.90	5.06	4.84	4.94	5.10	5.27	5.00	5.11	5.28	5.46							
Amps	16.6	16.9	17.4	18.0	17.8	18.2	18.7	19.3	19.1	19.5	20.1	20.8	20.3	20.8	21.4	22.1	21.5	22.0	22.6	23.4	22.6	23.2	23.9	24.7							
Hi PR	230	247	261	272	258	277	293	305	293	315	333	347	334	359	379	396	375	404	427	445	415	446	471	492							
Lo PR	114	121	132	140	120	128	139	148	125	133	145	154	131	139	152	162	137	146	159	170	142	151	165	176							
MBh	55.9	56.9	59.6	63.6	54.6	55.6	58.3	62.1	53.3	54.3	56.9	60.7	52.0	53.0	55.5	59.2	49.4	50.3	52.7	56.2	45.7	46.6	48.8	52.1							
S/T	0.92	0.89	0.80	0.65	0.95	0.92	0.83	0.67	0.98	0.94	0.85	0.69	1.00	0.97	0.88	0.71	1.00	1.00	0.91	0.74	1.00	1.00	0.92	0.75							
ΔT	27	27	25	22	28	27	26	22	28	27	26	22	28	27	26	22	26	26	27	25	22	24	25	24	21						
KW	3.82	3.89	4.01	4.14	4.10	4.19	4.32	4.45	4.35	4.44	4.58	4.73	4.57	4.67	4.82	4.98	4.76	4.86	5.02	5.19	4.92	5.03	5.19	5.37							
Amps	16.3	16.7	17.2	17.7	17.5	17.9	18.4	19.0	18.8	19.2	19.8	20.5	20.0	20.4	21.0	21.7	21.1	21.6	22.2	23.0	22.3	22.8	23.5	24.3							
Hi PR	225	242	256	267	252	272	287	299	287	309	326	340	327	352	372	388	368	396	418	436	407	438	462	482							
Lo PR	111	118	129	138	118	125	137	145	122	130	142	151	128	137	149	159	135	143	156	166	139	148	162	172							

IDB: Entering Indoor Dry Bulb Temperature
 High and low pressures are measured at the liquid and suction service valves.
 Design Subcooling, 5-7 °F @ the liquid access fitting connection AHRI 95 test conditions. Design Superheat 15-18°F @ the compressor suction access fitting connection.

Shaded area reflects AHRI conditions.

kW = Total system power
 Amps = outdoor unit amps (comp.+fan)

GPH1624M41*

HORIZONTAL POSITION	MOTOR SPEED	VOLTS	STATIC									
				0.1	0.2	0.3	0.4	0.5	0.6	0.7	0.8	0.9
	T1	230	CFM	671	616	567	---	---	---	---	---	---
Watts			51	57	72	---	---	---	---	---	---	---
T2/T3	230	CFM	941	872	777	746	614	---	---	---	---	---
		Watts	105	112	113	128	138	---	---	---	---	---
T4/T5	230	CFM	1347	1315	1256	1194	1152	1096	1051	972	891	---
		Watts	239	256	265	271	282	286	293	297	305	---

DOWNSHOT POSITION	MOTOR SPEED	VOLTS	STATIC									
				0.1	0.2	0.3	0.4	0.5	0.6	0.7	0.8	0.9
	T1	230	CFM	699	595	523	---	---	---	---	---	---
Watts			57	61	72	---	---	---	---	---	---	---
T2/T3	230	CFM	919	855	782	695	631	578	523	---	---	---
		Watts	108	117	121	132	143	144	149	---	---	---
T4/T5	230	CFM	1312	1275	1216	1153	1096	1028	943	869	816	---
		Watts	260	269	274	285	295	300	304	310	316	---

GPH1630M41*

HORIZONTAL POSITION	MOTOR SPEED	VOLTS	STATIC									
				0.1	0.2	0.3	0.4	0.5	0.6	0.7	0.8	0.9
	T1	230	CFM	743	707	595	513	---	---	---	---	---
Watts			61	73	77	85	---	---	---	---	---	---
T2/T3	230	CFM	1146	1098	1044	991	934	817	764	698	653	---
		Watts	157	170	176	186	194	201	210	215	215	---
T4/T5	230	CFM	1440	1418	1364	1307	1265	1219	1168	1094	1049	---
		Watts	290	306	312	321	326	332	348	353	360	---

DOWNSHOT POSITION	MOTOR SPEED	VOLTS	STATIC									
				0.1	0.2	0.3	0.4	0.5	0.6	0.7	0.8	0.9
	T1	230	CFM	722	672	574	509	---	---	---	---	---
Watts			60	74	80	89	---	---	---	---	---	---
T2/T3	230	CFM	1103	1038	978	922	806	731	676	622	564	---
		Watts	162	168	179	188	199	205	208	214	219	---
T4/T5	230	CFM	1401	1357	1305	1244	1179	1118	1046	934	884	---
		Watts	311	326	318	334	341	349	353	352	357	---

GPH1636M41*

HORIZONTAL POSITION	MOTOR SPEED	VOLTS	STATIC									
				0.1	0.2	0.3	0.4	0.5	0.6	0.7	0.8	0.9
	T1	230	CFM	846	762	716	585	519	---	---	---	---
Watts			74	83	94	98	108	---	---	---	---	---
T2/T3	230	CFM	1278	1214	1182	1129	1072	1013	950	853	788	---
		Watts	221	218	232	245	253	264	265	275	272	---
T4/T5	230	CFM	1604	1560	1507	1468	1415	1364	1321	1276	1218	---
		Watts	396	402	408	424	426	423	444	454	454	---

GPH1636M41* (CONT.)

DOWNSHOT POSITION	MOTOR SPEED	VOLTS	STATIC									
				0.1	0.2	0.3	0.4	0.5	0.6	0.7	0.8	0.9
	T1	230	CFM	809	730	623	542	485	441	---	---	---
Watts			73	85	92	98	107	112	---	---	---	
T2/T3	230	CFM	1284	1223	1175	1097	1031	974	871	804	761	
		Watts	220	227	241	247	255	262	272	277	285	
T4/T5	230	CFM	1578	1539	1498	1452	1396	1332	1279	1224	1161	
		Watts	401	409	421	425	438	439	452	453	455	

GPH1642M41*

HORIZONTAL POSITION	MOTOR SPEED	VOLTS	STATIC									
				0.1	0.2	0.3	0.4	0.5	0.6	0.7	0.8	0.9
	T1	230	CFM	1030	955	908	826	761	678	633	563	504
Watts			130	126	139	143	154	168	171	181	185	
T2/T3	230	CFM	1425	1373	1303	1250	1228	1158	1109	1042	982	
		Watts	234	246	248	262	280	290	298	308	322	
T4/T5	230	CFM	1775	1718	1673	1643	1588	1532	1482	1431	1369	
		Watts	416	424	430	454	458	466	478	488	490	

DOWNSHOT POSITION	MOTOR SPEED	VOLTS	STATIC									
				0.1	0.2	0.3	0.4	0.5	0.6	0.7	0.8	0.9
	T1	230	CFM	1001	936	852	810	700	643	579	526	491
Watts			125	133	136	154	160	166	172	177	185	
T2/T3	230	CFM	1411	1361	1299	1240	1173	1112	1048	955	887	
		Watts	281	294	301	309	312	320	327	335	339	
T4/T5	230	CFM	1745	1690	1615	1580	1530	1470	1420	1370	1310	
		Watts	425	435	440	465	468	476	488	498	500	

GPH1648M41*

HORIZONTAL POSITION	MOTOR SPEED	VOLTS	STATIC									
				0.1	0.2	0.3	0.4	0.5	0.6	0.7	0.8	0.9
	T1	230	CFM	1167	1101	1045	992	939	870	802	732	681
Watts			139	144	156	165	177	193	203	217	223	
T2/T3	230	CFM	1723	1637	1598	1554	1509	1467	1420	1361	1295	
		Watts	372	370	381	390	404	411	420	427	441	
T4/T5	230	CFM	2012	1965	1912	1871	1809	1770	1741	1691	1635	
		Watts	578	593	599	606	610	627	626	634	638	

DOWNSHOT POSITION	MOTOR SPEED	VOLTS	STATIC									
				0.1	0.2	0.3	0.4	0.5	0.6	0.7	0.8	0.9
	T1	230	CFM	1155	1074	1023	969	896	805	755	667	626
Watts			153	156	169	180	195	205	216	226	230	
T2/T3	230	CFM	1670	1596	1558	1484	1467	1383	1339	1259	1168	
		Watts	383	392	399	408	419	434	436	447	449	
T4/T5	230	CFM	1949	1881	1853	1792	1753	1699	1621	1561	1522	
		Watts	603	607	608	616	622	626	648	650	645	

GPH1660M41*

DOWNSHOT

SPEED TAP	STATIC	CFM	AMPS	WATTS	RPM
T1	0.1	1334	1.65	180	627
	0.2	1286	1.75	192	665
	0.3	1212	1.83	202	715
	0.4	1144	1.94	216	759
	0.5	1077	1.99	222	792
	0.6	1039	2.10	238	830
	0.7	953	2.17	248	874
	0.8	904	2.27	258	913
	0.9	825	2.30	266	940
T2	0.1	1512	2.12	240	682
	0.2	1469	2.24	254	720
	0.3	1397	2.31	264	759
	0.4	1333	2.44	282	803
	0.5	1285	2.54	296	836
	0.6	1221	2.59	304	874
	0.7	1173	2.72	322	913
	0.8	1118	2.77	328	946
	0.9	1049	2.90	344	984
T3	0.1	2053	4.27	540	869
	0.2	2014	4.39	558	896
	0.3	1999	4.60	576	929
	0.4	1947	4.68	588	957
	0.5	1897	4.79	608	989
	0.6	1857	4.87	620	1012
	0.7	1763	4.99	640	1050
	0.8	1741	5.06	650	1072
	0.9	1669	5.19	668	1105
T4	0.1	2137	4.95	634	913
	0.2	2093	5.07	652	940
	0.3	2095	5.19	670	962
	0.4	2026	5.28	682	990
	0.5	1980	5.40	698	1018
	0.6	1961	5.49	720	1039
	0.7	1914	5.58	732	1072
	0.8	1845	5.70	742	1100
	0.9	1766	5.69	740	1127
T5	0.1	2299	5.70	742	942
	0.2	2233	5.80	748	969
	0.3	2217	5.90	768	990
	0.4	2157	6.07	786	1018
	0.5	2131	6.12	804	1045
	0.6	2060	6.21	816	1073
	0.7	2015	6.30	820	1095
	0.8	1940	6.27	816	1111
	0.9	1862	6.13	790	1128

HORIZONTAL

SPEED TAP	ESP IN W.C.	CFM	AMPS	WATTS	RPM
T1	0.1	1355	1.57	174	599
	0.2	1281	1.66	182	651
	0.3	1235	1.76	196	693
	0.4	1168	1.81	202	726
	0.5	1118	1.94	218	775
	0.6	1049	2.03	232	819
	0.7	982	2.10	240	858
	0.8	922	2.14	246	885
	0.9	871	2.25	260	927
T2	0.1	1544	2.04	234	660
	0.2	1490	2.17	250	704
	0.3	1427	2.25	260	742
	0.4	1370	2.35	276	781
	0.5	1319	2.42	282	809
	0.6	1274	2.52	296	849
	0.7	1210	2.62	316	891
	0.8	1137	2.73	326	935
	0.9	1106	2.77	336	957
T3	0.1	2099	4.13	516	825
	0.2	2068	4.25	536	852
	0.3	2029	4.37	552	885
	0.4	1971	4.48	568	913
	0.5	1911	4.61	586	950
	0.6	1876	4.73	604	973
	0.7	1821	4.86	622	1012
	0.8	1792	4.91	630	1028
	0.9	1740	5.03	648	1067
T4	0.1	2233	4.76	608	863
	0.2	2168	4.91	628	896
	0.3	2125	5.02	640	924
	0.4	2070	5.14	660	951
	0.5	2050	5.27	678	979
	0.6	1980	5.41	696	1012
	0.7	1954	5.47	704	1034
	0.8	1893	5.60	724	1067
	0.9	1852	5.70	736	1089
T5	0.1	2322	5.44	710	904
	0.2	2294	5.55	726	934
	0.3	2254	5.68	742	958
	0.4	2201	5.80	766	990
	0.5	2147	5.93	782	1017
	0.6	2117	6.01	788	1039
	0.7	2081	6.12	808	1060
	0.8	2017	6.22	822	1094
	0.9	1932	6.10	804	1111

NOTES

- Table represent dry coil without filter, to compensate for filter add 0.08" to measured E.S.P..
- SCFM correction for wet coil = 4%.
- 5-ton models are shipped from the factory with speed tap set on T4.

AIRFLOW PRESSURE DROP OF DOWNFLOW ECONOMIZER FOR 3 TO 6 TON ROOFTOP UNITS (100% RETURN AIR)											
SCFM	800	1000	1200	1400	1600	1800	2000	2200	2400	2600	2800
in. WG	0.02	0.04	0.05	0.07	0.09	0.12	0.14	0.17	0.21	0.24	0.28

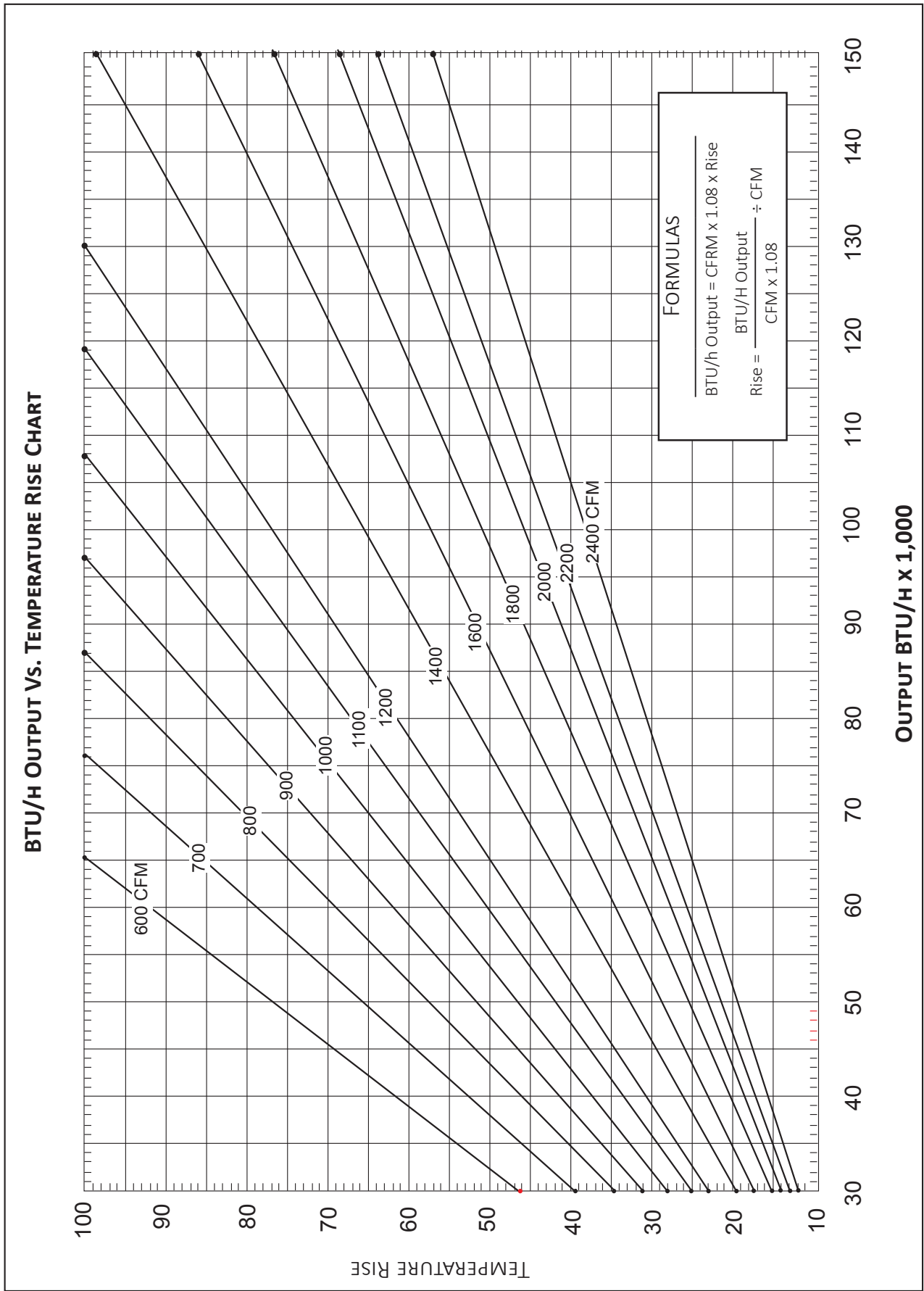

EXPANDED HEATING DATA

GPH1624M41**

	OUTDOOR AMBIENT TEMPERATURE																	
	65	60	55	50	47	45	40	35	30	25	20	17	15	10	5	0	-5	-10
MBh	28.7	27.1	25.5	23.9	22.8	22.1	20.5	18.9	15.6	14.4	13.2	12.5	12.0	10.8	9.6	8.4	7.1	5.8
T/R	31.2	29.6	27.8	26.0	24.8	24.1	22.4	20.6	17.0	15.7	14.4	13.6	13.1	11.8	10.4	9.1	7.8	6.4
kW	1.96	1.92	1.88	1.84	1.82	1.80	1.76	1.72	1.68	1.64	1.60	1.58	1.56	1.52	1.49	1.45	1.41	1.37
amps	10.0	9.4	8.8	8.4	8.1	8.0	7.6	7.3	7.0	6.7	6.5	6.3	6.3	6.0	5.7	5.4	5.1	4.7
COP	4.28	4.14	3.98	3.80	3.67	3.59	3.41	3.21	2.71	2.57	2.42	2.32	2.25	2.07	1.89	1.69	1.48	1.25
EER	15	14	14	13	13	12	12	11	9	9	8	8	8	7	6	6	5	4
HI PR	397	381	366	350	342	336	323	310	297	283	272	265	261	251	241	231	223	215
LO PR	141.8	131.6	123.3	113.1	106.9	102.8	94.6	84.2	76.0	67.9	59.6	55.5	53.4	45.2	39.0	32.9	28.7	22.5

GPH1630M41**

	OUTDOOR AMBIENT TEMPERATURE																	
	65	60	55	50	47	45	40	35	30	25	20	17	15	10	5	0	-5	-10
MBh	35.7	33.8	31.8	29.7	28.4	27.5	25.6	23.6	20.7	19.1	17.6	16.6	16.0	14.3	12.7	11.1	9.5	7.8
T/R	31.5	29.8	28.0	26.2	25.0	24.3	22.5	20.8	18.2	16.8	15.5	14.6	14.1	12.6	11.2	9.8	8.3	6.8
kW	2.56	2.51	2.45	2.40	2.37	2.35	2.30	2.25	2.25	2.20	2.15	2.12	2.09	2.04	1.99	1.94	1.88	1.83
amps	12.9	12.0	11.3	10.7	10.4	10.2	9.7	9.2	8.9	8.5	8.2	8.0	7.9	7.6	7.2	6.8	6.4	5.9
COP	4.08	3.95	3.79	3.62	3.50	3.43	3.25	3.07	2.69	2.54	2.40	2.30	2.23	2.06	1.87	1.68	1.47	1.24
EER	14	13	13	12	12	12	11	10	9	9	8	8	8	7	6	6	5	4
HI PR	416	399	383	366	358	351	337	324	310	296	284	278	273	262	252	242	233	225
LO PR	134.9	125.2	117.3	107.6	101.7	97.8	90.0	80.1	72.3	64.6	56.7	52.8	50.8	43.0	37.1	31.3	27.3	21.5

GPH1636M41**

	OUTDOOR AMBIENT TEMPERATURE																	
	65	60	55	50	47	45	40	35	30	25	20	17	15	10	5	0	-5	-10
MBh	42.1	39.9	37.5	35.1	33.5	32.5	30.2	27.8	24.2	22.4	20.6	19.4	18.7	16.8	14.9	13.0	11.1	9.1
T/R	32.5	30.8	29.0	27.1	25.8	25.0	23.3	21.5	18.7	17.2	15.9	15.0	14.4	13.0	11.5	10.0	8.5	7.0
kW	2.85	2.79	2.73	2.67	2.64	2.62	2.56	2.50	2.48	2.42	2.37	2.33	2.31	2.25	2.19	2.14	2.08	2.02
amps	14.5	13.6	12.8	12.1	11.7	11.5	11.0	10.5	10.1	9.7	9.3	9.1	9.0	8.7	8.2	7.8	7.3	6.7
COP	4.33	4.18	4.02	3.84	3.71	3.63	3.45	3.25	2.85	2.70	2.54	2.44	2.37	2.18	1.99	1.78	1.56	1.31
EER	15	14	14	13	13	12	12	11	10	9	9	8	8	7	7	6	5	4
HI PR	399	383	368	352	344	337	324	311	298	285	273	267	262	252	242	232	224	216
LO PR	133.8	124.1	116.4	106.7	100.9	97.0	89.3	79.5	71.7	64.0	56.3	52.3	50.4	42.7	36.8	31.1	27.1	21.3

Notes

Above information is for nominal CFM and 70-degree indoor dry bulb. Instantaneous capacity listed.

High pressure is measured at the liquid line access fitting.

Low pressure is measured at the compressor suction access fitting.

Amps: Unit amps (comp.+ evaporator motor + condenser fan motor)

kW = Total system power

GPH1642M41

	OUTDOOR AMBIENT TEMPERATURE																	
	65	60	55	50	47	45	40	35	30	25	20	17	15	10	5	0	-5	-10
MBh	47.8	45.2	42.6	39.8	38.0	36.8	34.2	31.5	26.8	24.7	22.8	21.5	20.7	18.6	16.5	14.4	12.3	10.0
T/R	34.0	32.2	30.3	28.3	27.1	26.2	24.4	22.5	19.1	17.6	16.2	15.3	14.7	13.2	11.7	10.2	8.7	7.2
kW	3.53	3.46	3.38	3.31	3.27	3.24	3.17	3.10	2.94	2.87	2.80	2.76	2.73	2.66	2.59	2.53	2.46	2.39
amps	17.8	16.6	15.6	14.8	14.3	14.0	13.3	12.7	12.2	11.7	11.2	11.0	10.9	10.4	9.8	9.3	8.7	8.0
COP	3.96	3.83	3.68	3.51	3.40	3.33	3.16	2.98	2.67	2.52	2.38	2.28	2.22	2.04	1.86	1.66	1.46	1.23
EER	14	13	13	12	12	11	11	10	9	9	8	8	8	7	6	6	5	4
HI PR	417	399	384	367	359	352	338	324	311	297	285	278	273	263	253	242	234	226
LO PR	134.9	125.1	117.3	107.5	101.7	97.8	90.0	80.1	72.3	64.5	56.7	52.8	50.8	43.0	37.1	31.3	27.3	21.4

GPH1648M41

	OUTDOOR AMBIENT TEMPERATURE																	
	65	60	55	50	47	45	40	35	30	25	20	17	15	10	5	0	-5	-10
MBh	57.2	54.1	51.0	47.6	45.5	44.1	41.0	37.8	33.6	31.1	28.6	27.0	26.0	23.3	20.7	18.0	15.4	12.6
T/R	33.1	31.3	29.5	27.6	26.3	25.5	23.7	21.9	19.5	18.0	16.5	15.6	15.0	13.5	12.0	10.4	8.9	7.3
kW	3.94	3.86	3.78	3.71	3.66	3.63	3.55	3.47	3.36	3.28	3.21	3.16	3.13	3.05	2.98	2.90	2.82	2.75
amps	20.8	19.4	18.2	17.2	16.6	16.3	15.5	14.8	14.2	13.6	13.0	12.7	12.6	12.0	11.3	10.7	10.0	9.1
COP	4.25	4.10	3.94	3.76	3.64	3.56	3.37	3.18	2.93	2.77	2.61	2.50	2.43	2.24	2.03	1.82	1.59	1.34
EER	15	14	13	13	12	12	12	11	10	9	9	9	8	8	7	6	5	5
HI PR	404	387	372	356	348	341	328	315	301	288	276	270	265	255	245	235	227	219
LO PR	133.3	123.7	115.9	106.3	100.5	96.6	88.9	79.2	71.4	63.8	56.1	52.1	50.2	42.5	36.7	30.9	27.0	21.2

GPH1660M41

	OUTDOOR AMBIENT TEMPERATURE																	
	65	60	55	50	47	45	40	35	30	25	20	17	15	10	5	0	-5	-10
MBh	69.7	66.0	62.1	58.0	55.4	53.7	49.9	46.0	38.2	35.3	32.5	30.7	29.5	26.5	23.5	20.5	17.5	14.3
T/R	32.9	31.1	29.3	27.4	26.2	25.4	23.5	21.7	18.0	16.6	15.3	14.5	13.9	12.5	11.1	9.7	8.3	6.8
kW	4.54	4.45	4.36	4.28	4.23	4.19	4.11	4.02	3.94	3.85	3.77	3.72	3.68	3.59	3.51	3.42	3.34	3.25
amps	23.7	22.1	20.8	19.7	19.0	18.7	17.8	17.0	16.3	15.7	15.0	14.7	14.6	13.9	13.1	12.5	11.7	10.7
COP	4.49	4.34	4.16	3.97	3.84	3.75	3.56	3.35	2.84	2.68	2.52	2.42	2.35	2.16	1.96	1.75	1.53	1.29
EER	15	15	14	14	13	13	12	11	10	9	9	8	8	7	7	6	5	4
HI PR	295	283	272	260	254	249	239	230	220	210	202	197	193	186	179	171	165	160
LO PR	133.4	123.7	116.0	106.3	100.5	96.7	88.9	79.2	71.5	63.8	56.1	52.2	50.3	42.5	36.7	31.0	27.0	21.2

Notes

Above information is for nominal CFM and 70-degree indoor dry bulb. Instantaneous capacity listed.

High pressure is measured at the liquid line access fitting.

Low pressure is measured at the compressor suction access fitting.

Amps: Unit amps (comp.+ evaporator motor + condenser fan motor)

kW = Total system power

AUXILIARY HEATING DATA

GPH1624M41						
CONDITIONS: 850 CFM; INDOOR AIR @ 70°F DB						
OUTDOOR AMBIENT °F.	BASIC UNIT W/O AUXILIARY HEAT		UNIT CAPACITY WITH KW OF AUXILIARY HEAT			
	CAPACITY*	COP	4.8	9.6	14.4	19.2
65	28.66	4.28	45.04	61.42	-	-
60	27.13	4.14	43.51	59.90	-	-
55	25.54	3.97	41.92	58.30	-	-
50	23.87	3.79	40.25	56.64	-	-
45	22.09	3.58	38.48	54.86	-	-
40	20.52	3.40	36.90	53.28	-	-
35	18.92	3.21	35.31	51.69	-	-
30	15.58	2.72	31.96	48.34	-	-
25	14.38	2.57	30.76	47.14	-	-
20	13.24	2.42	29.62	46.00	-	-
15	12.04	2.25	28.42	44.80	-	-
10	10.80	2.07	27.18	43.56	-	-
5	9.58	1.88	25.96	42.34	-	-
0	8.35	1.68	24.73	41.11	-	-
-5	7.13	1.48	23.51	39.89	-	-
-10	5.84	1.24	22.22	38.60	-	-

GPH1630M41						
CONDITIONS: 1050 CFM; INDOOR AIR @ 70°F DB						
OUTDOOR AMBIENT °F.	BASIC UNIT W/O AUXILIARY HEAT		UNIT CAPACITY WITH KW OF AUXILIARY HEAT			
	CAPACITY*	COP	4.8	9.6	14.4	19.2
65	35.70	4.09	52.08	68.46	84.846	-
60	33.80	3.95	50.18	66.56	82.9432	-
55	31.81	3.80	48.19	64.57	80.9552	-
50	29.73	3.63	46.12	62.50	78.882	-
45	27.52	3.43	43.90	60.28	76.6668	-
40	25.56	3.26	41.94	58.32	74.7072	-
35	23.57	3.07	39.95	56.34	72.7192	-
30	20.68	2.68	37.07	53.45	69.8308	-
25	19.09	2.53	35.47	51.85	68.2372	-
20	17.58	2.39	33.96	50.34	66.7266	-
15	15.99	2.23	32.37	48.75	65.133	-
10	14.34	2.05	30.72	47.11	63.4896	-
5	12.72	1.87	29.10	45.48	61.8628	-
0	11.09	1.67	27.47	43.85	60.236	-
-5	9.46	1.47	25.84	42.23	58.6092	-
-10	7.75	1.24	24.13	40.52	56.8994	-

GPH1636M41						
CONDITIONS: 1200 CFM; INDOOR AIR @ 70°F DB						
OUTDOOR AMBIENT °F.	BASIC UNIT W/O AUXILIARY HEAT		UNIT CAPACITY WITH KW OF AUXILIARY HEAT			
	CAPACITY*	COP	4.8	9.6	14.4	19.2
65	42.11	4.33	58.49	74.87	91.27	-
60	39.87	4.18	56.25	72.63	89.01	-
55	37.52	4.02	53.90	70.28	86.67	-
50	35.07	3.84	51.46	67.84	84.22	-
45	32.46	3.63	48.84	65.23	81.61	-
40	30.15	3.45	46.53	62.91	79.30	-
35	27.81	3.25	44.19	60.57	76.95	-
30	24.22	2.86	40.60	56.99	73.37	-
25	22.36	2.70	38.74	55.12	71.50	-
20	20.59	2.55	36.97	53.35	69.73	-
15	18.72	2.37	35.10	51.49	67.87	-
10	16.80	2.19	33.18	49.56	65.94	-
5	14.89	1.99	31.27	47.66	64.04	-
0	12.99	1.78	29.37	45.75	62.13	-
-5	11.08	1.56	27.46	43.85	60.23	-
-10	9.08	1.32	25.46	41.84	58.23	-

GPH1642M41						
CONDITIONS: 1300 CFM; INDOOR AIR @ 70°F DB						
OUTDOOR AMBIENT °F.	BASIC UNIT W/O AUXILIARY HEAT		UNIT CAPACITY WITH KW OF AUXILIARY HEAT			
	CAPACITY*	COP	4.8	9.6	14.4	19.2
65	47.77	3.99	64.15	80.53	96.91	-
60	45.22	3.85	61.60	77.98	94.37	-
55	42.56	3.69	58.94	75.32	91.71	-
50	39.79	3.52	56.17	72.55	88.93	-
45	36.82	3.32	53.20	69.59	85.97	-
40	34.20	3.15	50.58	66.96	83.35	-
35	31.54	2.96	47.92	64.30	80.69	-
30	26.91	2.70	43.30	59.68	76.06	-
25	24.84	2.55	41.22	57.60	73.99	-
20	22.87	2.39	39.26	55.64	72.02	-
15	20.80	2.22	37.18	53.57	69.95	-
10	18.66	2.04	35.04	51.43	67.81	-
5	16.55	1.85	32.93	49.31	65.69	-
0	14.43	1.65	30.81	47.19	63.58	-
-5	12.31	1.44	28.69	45.08	61.46	-
-10	10.09	1.21	26.47	42.85	59.23	-

GPH1648M41						
CONDITIONS: 1600 CFM; INDOOR AIR @ 70°F DB						
OUTDOOR AMBIENT °F.	BASIC UNIT W/O AUXILIARY HEAT		UNIT CAPACITY WITH KW OF AUXILIARY HEAT			
	CAPACITY*	COP	4.8	9.6	14.4	19.2
65	57.19	4.25	73.58	89.96	106.34	122.72
60	54.15	4.10	70.53	86.91	103.29	119.67
55	50.96	3.94	67.34	83.72	100.11	116.49
50	47.64	3.76	64.02	80.40	96.78	113.17
45	44.09	3.56	60.47	76.85	93.24	109.62
40	40.95	3.37	57.33	73.71	90.10	106.48
35	37.77	3.18	54.15	70.53	86.91	103.29
30	33.64	2.93	50.02	66.41	82.79	99.17
25	31.05	2.77	47.43	63.81	80.20	96.58
20	28.59	2.61	44.98	61.36	77.74	94.12
15	26.00	2.43	42.38	58.77	75.15	91.53
10	23.33	2.24	39.71	56.09	72.48	88.86
5	20.68	2.03	37.06	53.45	69.83	86.21
0	18.04	1.82	34.42	50.80	67.18	83.57
-5	15.39	1.60	31.77	48.15	64.54	80.92
-10	12.61	1.34	28.99	45.37	61.76	78.14

GPH1660M41					
CONDITION : 2000 CFM; INDOOR AIR @ 70 °F DB					
OUTDOOR AMBIENT °F.	BASIC UNIT W/O AUXILIARY HEAT		UNIT CAPACITY WITH KW OF AUX. HEAT		
	CAPACITY*	COP	10	15	20
65	69.70	4.49	103.82	120.88	137.94
60	66.00	4.34	100.12	117.18	134.24
55	62.10	4.16	96.22	113.28	130.34
50	58.00	3.97	92.22	109.28	126.34
45	53.70	3.75	87.82	104.88	121.94
40	49.90	3.56	84.02	101.08	118.14
35	46.00	3.35	80.12	97.18	114.24
30	38.20	2.84	71.82	88.88	105.94
25	35.30	2.68	68.92	85.98	103.04
20	32.50	2.52	66.22	83.28	100.34
15	29.50	2.35	63.32	80.38	97.44
10	26.50	2.16	60.32	77.38	94.44
5	23.50	1.96	57.32	74.38	91.44
0	20.50	1.75	54.32	71.38	88.44
-5	17.50	1.53	51.42	68.48	85.54
-10	14.30	1.29	48.22	65.28	82.34

NOTES

- COP: Coefficient of performance
- To obtain BTU capacity of the unit with Kw of auxiliary heat, multiply by 1000 (example 39.01 x 1000 = 39,010 BTU'S)

MODEL AND HEAT KIT USAGE	CIRCUIT #1		CIRCUIT #2		ACTUAL kW / BTU@ 240V
	MCA ¹	MOD ²	MCA ¹	MOD ²	
GPH1624M41**	4.3 / 4.3	--	--	--	--
HKP-05C*	24 / 27	30 / 30	--	--	4.75 / 16,200
HKR-08*, HKR-08C*	34 / 39	40 / 40	--	--	7.0 / 23,800
HKP-10C*	45 / 52	60 / 60	--	--	9.5 / 32,400
GPH1630M41**	4.3 / 4.3	--	--	--	--
HKP-05C*	24 / 27	30 / 30	--	--	4.75 / 16,200
HKR-08*, HKR-08C*	34 / 39	40 / 40	--	--	7.0 / 23,800
HKP-10C*	45 / 52	60 / 60	--	--	9.5 / 32,400
HKP-15C*	45 / 52	60 / 60	22 / 25	30 / 30	14.25 / 48,600
GPH1636M41**	4.3 / 4.3	--	--	--	--
HKP-05C*	24 / 27	30 / 30	--	--	4.75 / 16,200
HKR-08*, HKR-08C*	34 / 39	40 / 40	--	--	7.0 / 23,800
HKP-10C*	45 / 52	60 / 60	--	--	9.5 / 32,400
HKP-15C*	45 / 52	60 / 60	22 / 25	30 / 30	14.25 / 48,600
GPH1642M41**	5.8/5.8	--	--	--	--
HKP-05C*	24 / 27	30 / 30	--	--	4.75 / 16,200
HKR08A,CA	34 / 39	40 / 40	--	--	7.0 / 23,800
HKP-10C*	45 / 52	60 / 60	--	--	9.5 / 32,400
HKP-15C*	45 / 52	60 / 60	22 / 25	30 / 30	14.25 / 48,600
GPH1648M41* *	5.8/5.8	--	--	--	--
HKP-05C*	25 / 28	30 / 30	----	----	4.75 / 16,200
HKR08A,CA	34 / 40	40 / 40	----	----	7.00 / 23,800
HKP-10C*	46 / 53	60 / 60	----	----	9.50 / 32,400
HKP-15C*	46 / 52	60 / 60	22 / 25	30 / 30	14.25 / 48,600
HKP-20C*	46 / 52	60 / 60	43 / 49	60 / 60	19.50 / 66,500

¹ Minimum Circuit Ampacity @ 240 V
² Maximum Overcurrent Protection device @ 240 V
* Revision level that may or may not be designated
C Circuit Breaker option

MODEL AND HEAT KIT USAGE	MCA ¹ @ 208 / 240V	MOP ² (AMPS) @ 208 / 240V	ACTUAL kW & BTU @ 240V	RECOMMENDED AIRFLOW RANGE
GPH1660M41* *			---	---
EHK1-10	53 / 62	60 / 70	10 / 34,000	1750-2250 CFM
EHK1-15	76 / 88	80 / 90	15 / 51,000	1750-2250 CFM
EHK1-20	99 / 114	100 / 120	20 / 68,200	1850-2250 CFM

¹ Minimum Circuit Ampacity
² Maximum Overcurrent Protection Device

KW CORRECTION FACTORS

kW CORRECTION FACTOR FOR 1- & 3-PHASE UNITS					
SUPPLY VOLTAGE	240	230	220	210	208
CORRECTION FACTOR	1	0.93	0.82	0.78	0.76

Multiply rated kW by correction factor to get actual kW

MINIMUM AIRFLOW FOR ELECTRIC HEAT

HEATER SIZE	MINIMUM CFM
10 kW	1,250
15 kW	1,400
20 kW	1,850

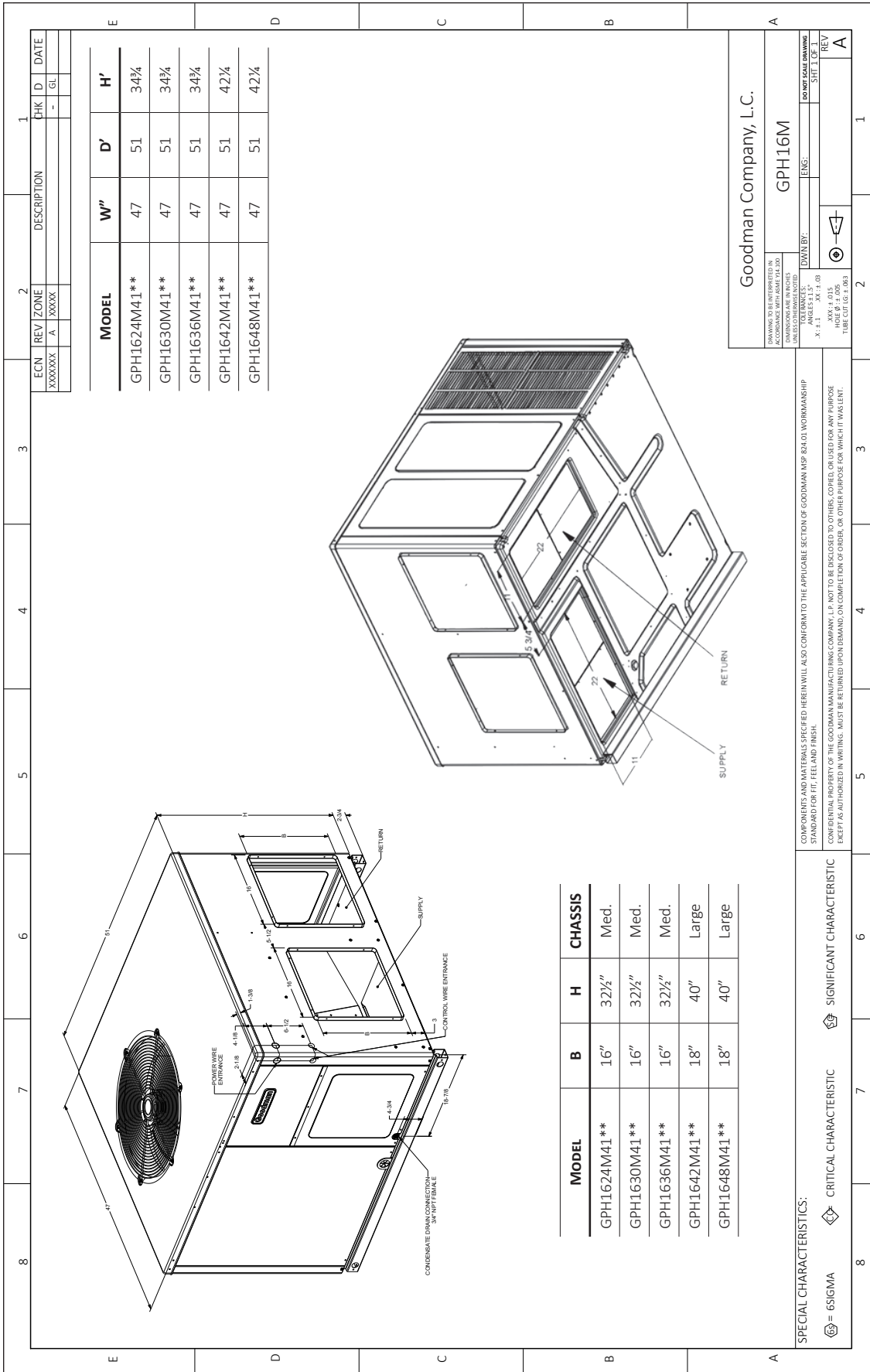

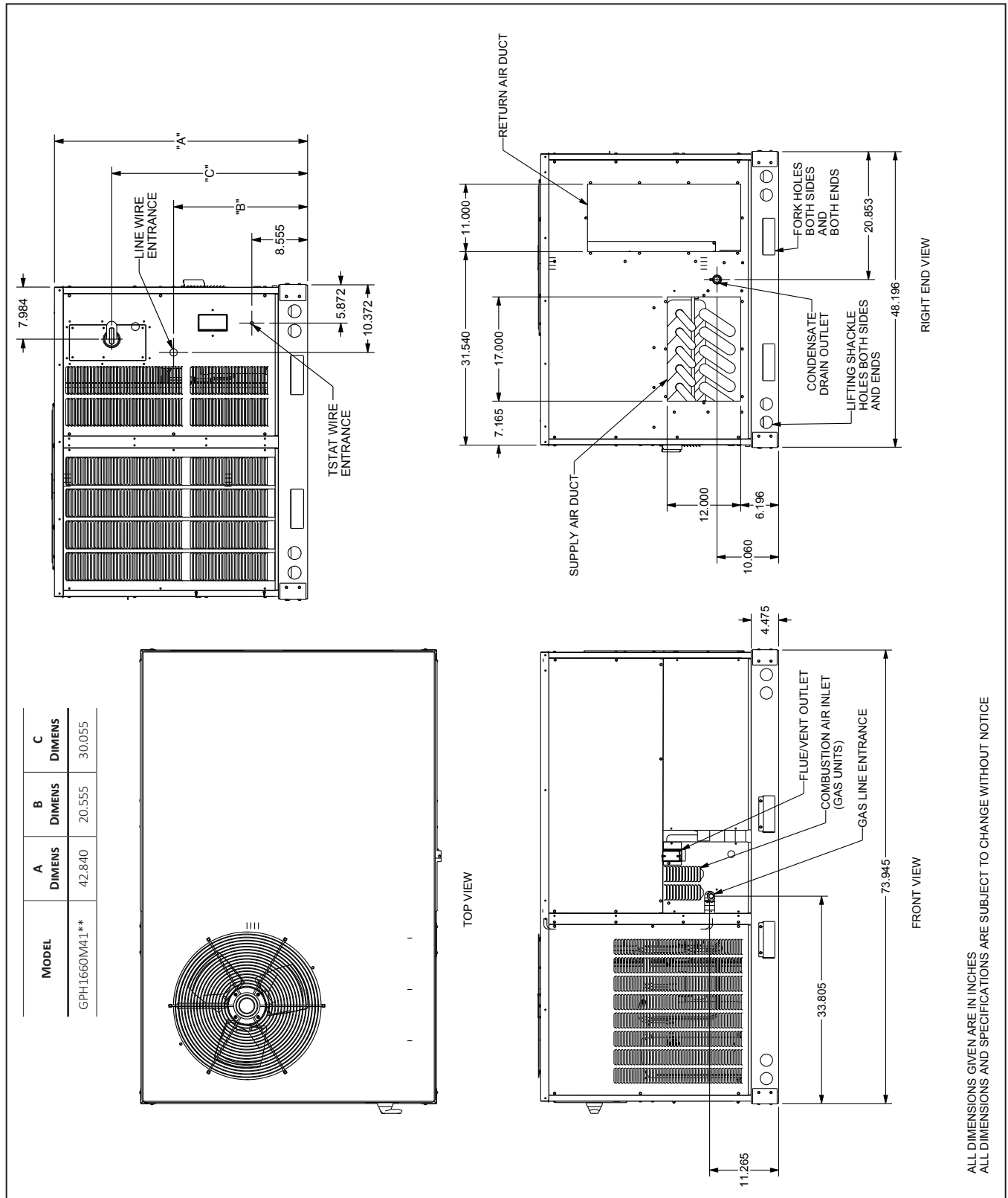

MODEL	A DIMENS	B DIMENS	C DIMENS
GPH1660M41**	42.840	20.555	30.055

ALL DIMENSIONS GIVEN ARE IN INCHES
ALL DIMENSIONS AND SPECIFICATIONS ARE SUBJECT TO CHANGE WITHOUT NOTICE

Provisions for forks have been included in the unit base frame. No other fork locations are approved.

- Unit must be lifted by the four lifting holes located at the base frame corners.
- Lifting cables should be attached to the unit with shackles.
- The distance between the crane hook and the top of the unit must not be less than 60”.
- Two spreader bars must span over the unit to prevent damage to the cabinet by the lift cables. Spreader bars must be of sufficient length so that cables do not come in contact with the unit during transport. Remove wood struts mounted beneath unit base frame before setting unit on roof curb. These struts are intended to protect unit base frame from fork lift damage. To remove the struts, extract the sheet metal retainers and pull the struts through the base of the unit. Refer to rigging label on the unit.

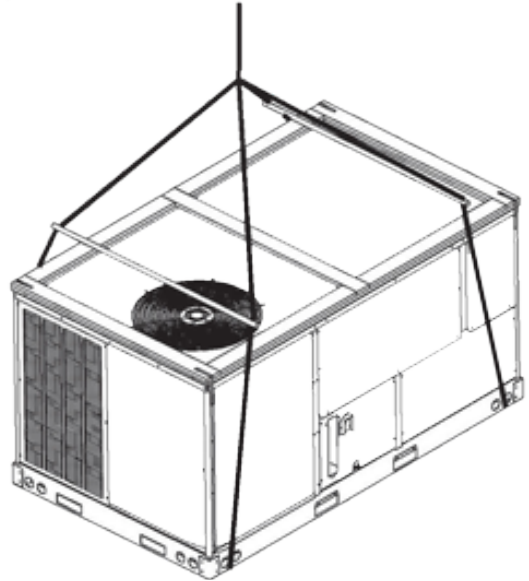

Important: If using bottom discharge with roof curb, duct-work should be attached to the curb prior to installing the unit. Duct-work dimensions are shown in Roof Curb Installation Instructions Manual.

Refer to the Roof Curb Installation Instructions for proper curb installation. Curbing must be installed in compliance with the National Roofing Contractors Association Manual.

Lower unit carefully onto roof mounting curb. While rigging the unit, the center of gravity will cause the condenser end to be lower than the supply air end.

Bring condenser end of unit into alignment with the curb. With condenser end of the unit resting on curb member and using curb as a fulcrum, lower opposite end of the unit until entire unit is seated on the curb. When a rectangular cantilever curb is used, take care to center the unit. Check for proper alignment and orientation of supply and return openings with duct.

To assist in determining rigging requirements, unit weights are shown on the following page.

Curb installations must comply with local codes and should follow the established guidelines of the National Roofing Contractors Association.

Proper unit installation requires that the roof curb be firmly and permanently attached to the roof structure. Check for adequate fastening method prior to setting the unit on the curb.

Full perimeter roof curbs are available from the factory and are shipped unassembled. The installing contractor is responsible for field assembly, squaring, leveling, and mounting on the roof structure. All required hardware necessary for the assembly of the sheet metal curb is included in the curb accessory package.

- Determine sufficient structural support before locating and mounting the curb and package unit.
- Duct-work must be constructed using industry guidelines. The duct-work must be placed into the roof curb before mounting the package unit. Our full perimeter curbs include duct connection frames to be assembled with the curb. Cantilevered-type curbs are not available from the factory.
- Contractor furnishes curb insulation, cant strips, flashing, and general roofing material.
- Support curbs on parallel sides with roof members. To prevent damage to the unit, the roof members cannot penetrate supply and return duct openings.

Note: The unit and curb accessories are designed to allow vertical duct installation before unit placement. Duct installation after unit placement is not recommended.

See the manual shipped with the roof curb for assembly and installation instructions.

3-D VIEW

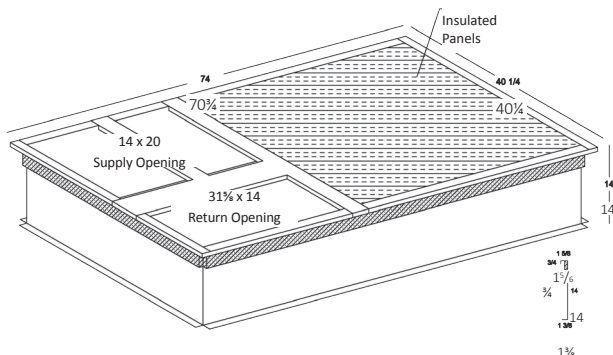

TOP VIEW

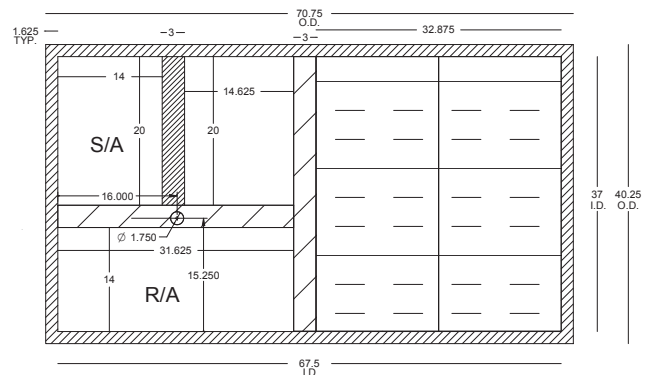

CORNER & CENTER-OF-GRAVITY LOCATIONS

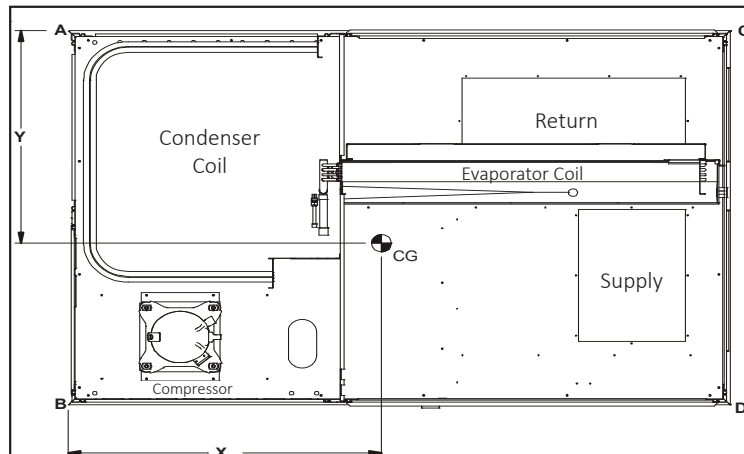

MODEL	X (IN)	Y (IN)	SHIPPING WEIGHT (LBS)	OPERATING WEIGHT (LBS)	CORNER WEIGHTS (LBS.)			
					A	B	C	D
GPH1660M41**	40.0	25.1	612	583	204	113	72	194

UNIT CLEARANCES

Maintain an adequate clearance around the unit for safety, service, maintenance, and proper unit operation. Leave a total clearance of 75" on the main control panel side of the unit for possible removal of fan shaft, coil, electric heat, and gas furnace. Leave a clearance of 48" on all other sides of the unit for possible compressor removal or service access, and to ensure proper ventilation and condenser airflow. Do not install the unit beneath any obstruction. Install the unit away from all building exhausts to inhibit ingestion of exhaust air into the unit's fresh-air intake.

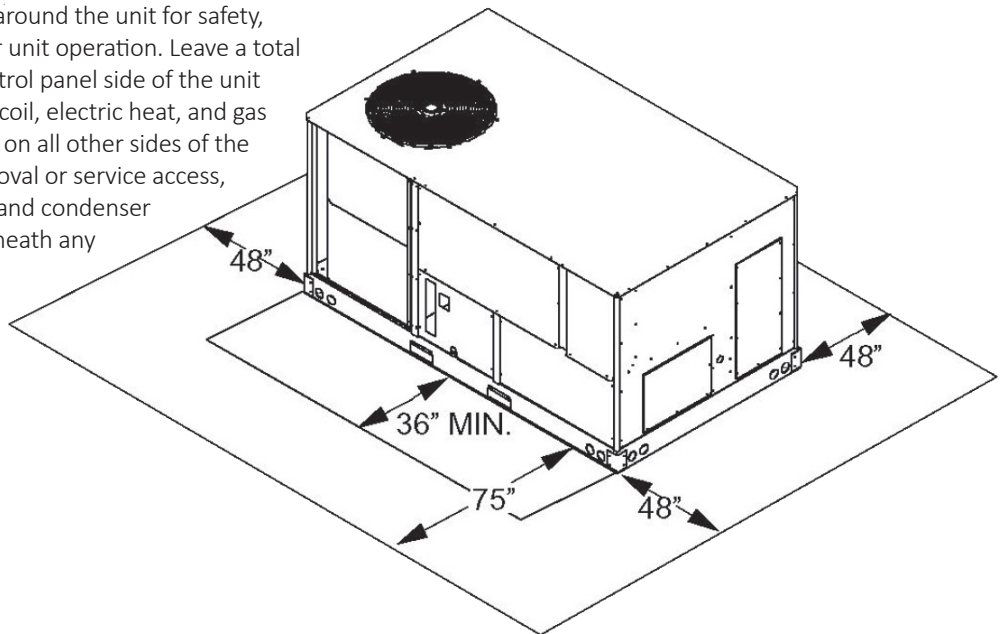

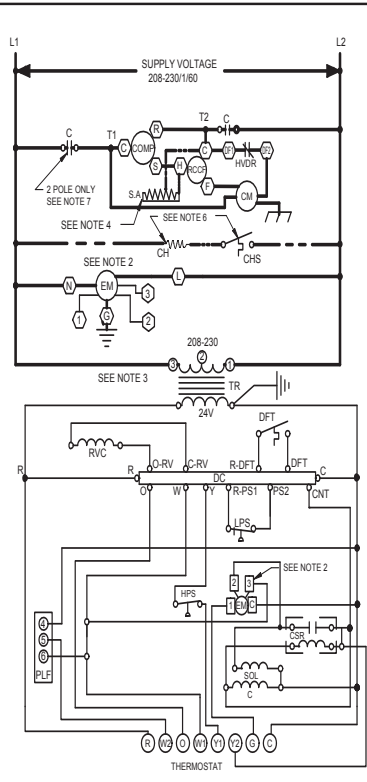
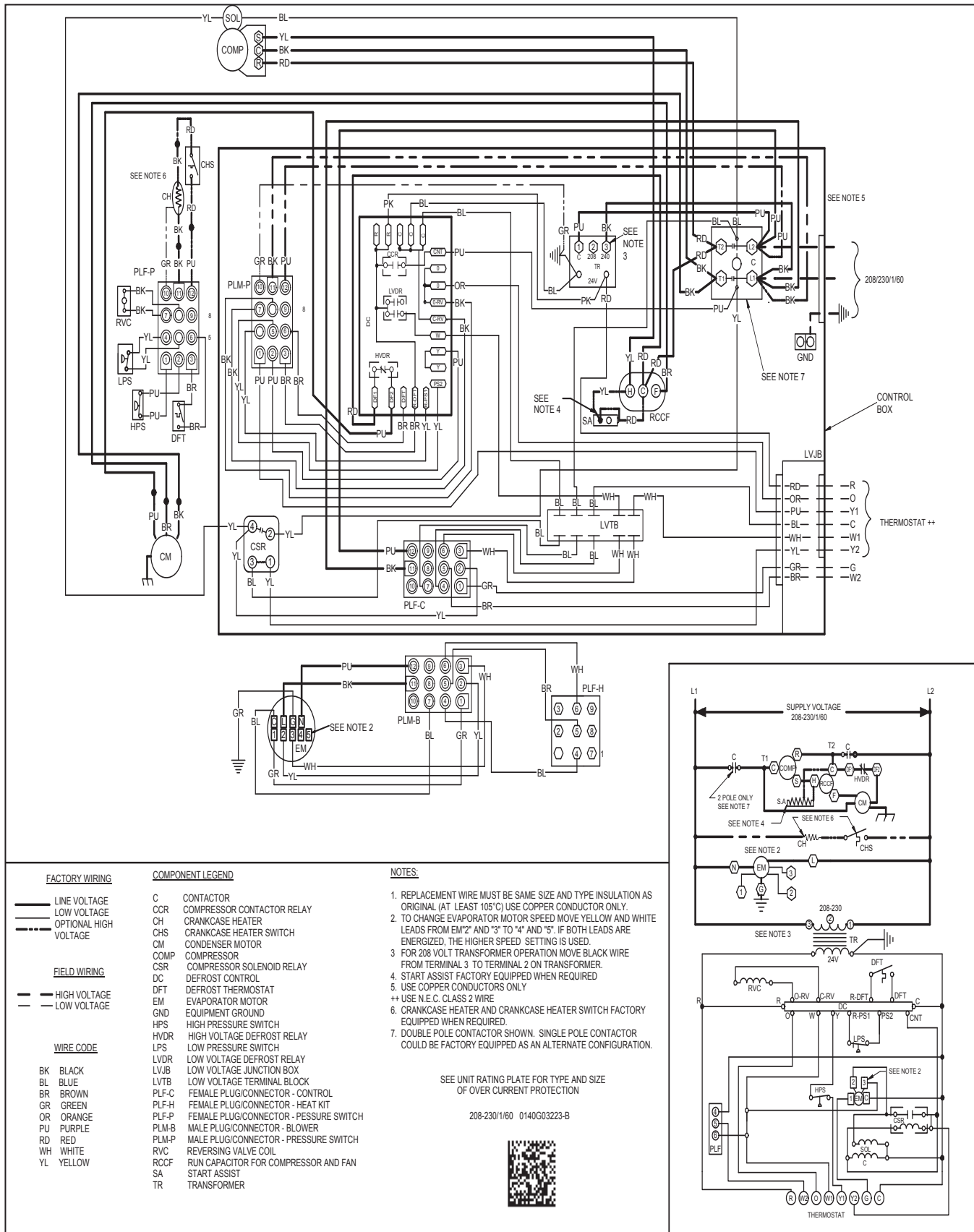

Wiring is subject to change. Always refer to the wiring diagram or the unit for the most up-to-date wiring.

WARNING

High Voltage: Disconnect all power before servicing or installing this unit. Multiple power sources may be present. Failure to do so may cause property damage, personal injury, or death.

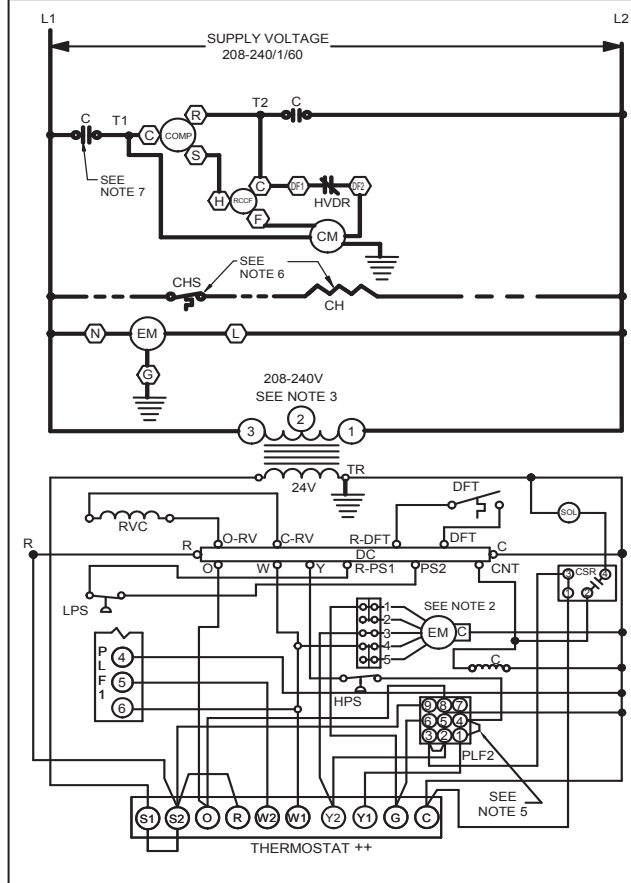
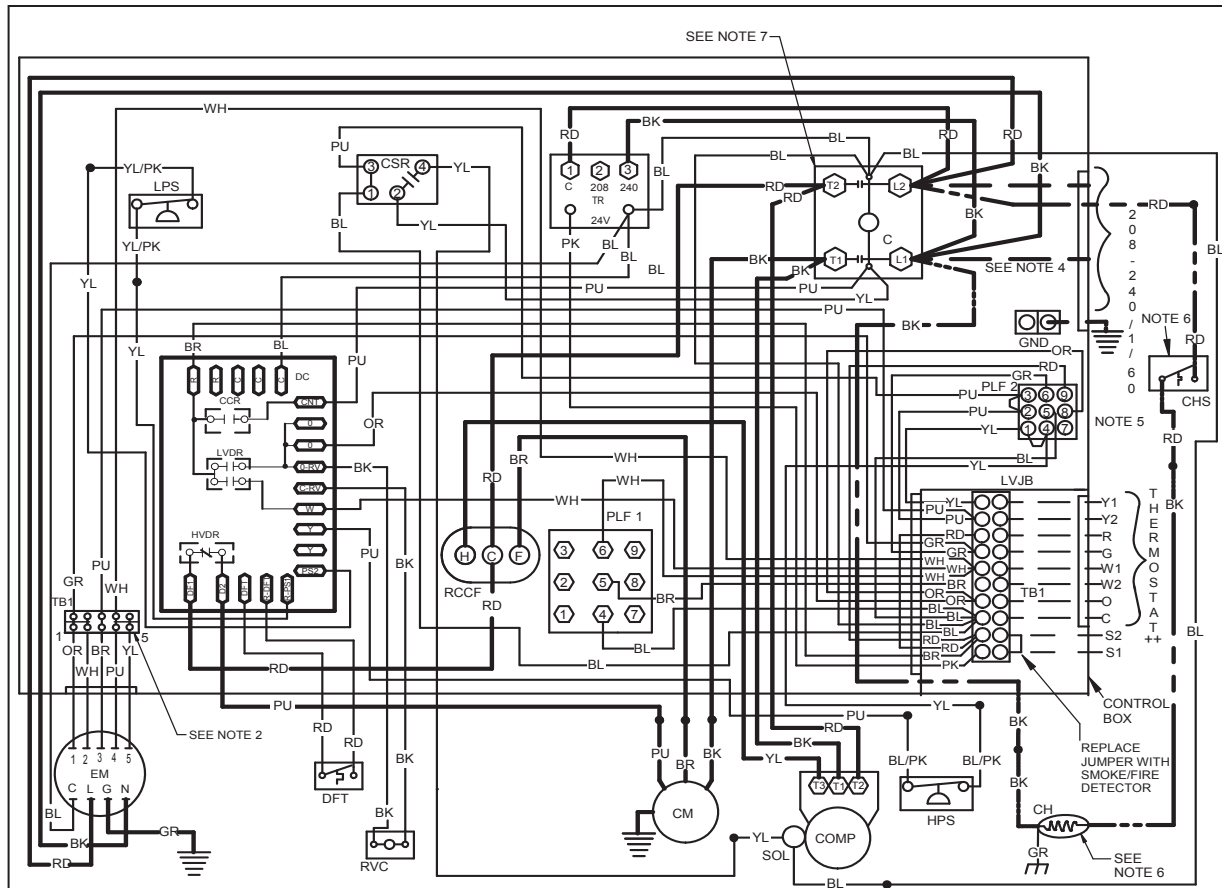

COMPONENT LEGEND

C	CONTACTOR
CCR	COMPRESSOR CONTACTOR RELAY
CH	CRANKCASE HEATER
CHS	CRANKCASE HEATER SWITCH
CM	CONDENSER MOTOR
COMP	COMPRESSOR
DC	DEFROST CONTROL
DFT	DEFROST THERMOSTAT
ECON	ECONOMIZER
EM	EVAPORATOR MOTOR
GND	EQUIPMENT GROUND
HPS	HIGH PRESSURE SWITCH
HVDR	HIGH VOLTAGE DEFROST RELAY
LPS	LOW PRESSURE SWITCH
LVDR	LOW VOLTAGE DEFROST RELAY
LVJB	LOW VOLTAGE JUNCTION BOX
PLF	FEMALE PLUG / CONNECTOR
RVC	REVERSING VALVE COIL
RCCF	RUN CAPACITOR FOR COMPRESSOR AND FAN
TB1	TERMINAL BLOCK (24V SIGNAL)
TR	TRANSFORMER

- NOTES:**
1. REPLACEMENT WIRE MUST BE SAME SIZE AND TYPE INSULATION AS ORIGINAL (AT LEAST 105°C) USE COPPER CONDUCTOR ONLY.
 2. TO CHANGE EVAPORATOR MOTOR SPEED MOVE WHITE AND YELLOW LEADS FROM "3" AND "4" TO "4" AND "5". IF BOTH LEADS ARE ENERGIZED, THE HIGHER SPEED SETTING IS USED.
 3. FOR 208 VOLT TRANSFORMER OPERATION MOVE BLACK WIRE FROM TERMINAL 3 TO TERMINAL 2 ON TRANSFORMER.
 4. USE COPPER CONDUCTORS ONLY
 5. USE N.E.C. CLASS 2 WIRE
 6. ECONOMIZER PLUG LOCATED IN THE RETURN AIR COMPARTMENT. REMOVE MALE PLUG AND ATTACH FEMALE PLUG TO ECONOMIZER ACCESSORY.
 7. CRANKCASE HEATER AND CRANKCASE HEATER SWITCH FACTORY EQUIPPED WHEN REQUIRED.
- SEE UNIT RATING PLATE FOR TYPE AND SIZE OF OVER CURRENT PROTECTION

JUNCTION	INTERNAL TO INTEGRATED CONTROL	PLUG CONNECTION	SWITCH (PRESS.)	OVERCURRENT PROT. DEVICE	EQUIPMENT GROUND	FIELD GROUND	FIELD SPLICE	SWITCH (TEMP)	IGNITER
----------	--------------------------------	-----------------	-----------------	--------------------------	------------------	--------------	--------------	---------------	---------

FACTORY WIRING

— LINE VOLTAGE
 - - - LOW VOLTAGE
 - · - · - OPTIONAL HIGH VOLTAGE
 - · - · - OPTIONAL LOW VOLTAGE

FIELD WIRING

— HIGH VOLTAGE
 - - - LOW VOLTAGE

WIRE CODE

BK BLACK
 BL BLUE
 BR BROWN
 GR GREEN
 OR ORANGE
 PK PINK
 RD RED
 PU PURPLE
 YL YELLOW
 WH WHITE
 BL/PK BLUE WITH PINK STRIP
 YL/PK YELLOW WITH PINK STRIP

High Voltage: Disconnect all power before servicing or installing this unit. Multiple power sources may be present. Failure to do so may cause property damage, personal injury, or death.

WARNING

Wiring is subject to change. Always refer to the wiring diagram or the unit for the most up-to-date wiring.



FOR THE GPH1624-48M41** UNITS

ACCESSORY DESCRIPTION	ITEM NUMBER	
	MEDIUM CHASSIS	LARGE CHASSIS
Concentric Kit	CDK36	CDK4872
Downflow Economizer	GPJMED102	GPJMED103
Downflow Internal Filter Rack	DDNIFRPCHMM	DDNIFRPCHML
Downflow Manual Damper	PGMDD101/102	PGMDD103
Downflow Motorized Damper	PGMDMD101/102	PGMDMD103
Downflow Square to Round	SQRPG101/102	SQRPG103
Economizer Wiring Harness	0259L00411	0259L00411
External Horizontal Filter Rack	DPHFRA	DPHFRA
Horizontal Duct Cover	20464501PDGK	20464502PDGK
Horizontal Economizer	DHZECNJPCHM	DHZECNJPCHL
Horizontal Manual Damper	PGMDH102	PGMDH103
Horizontal Motorized Damper	PGMDMH102	PGMDMH103
Horizontal Square to Round	SQRPGH101/102	SQRPGH103
Outdoor Thermostat & Emergency Heat Relay Kit	OT/EHR18-60	OT/EHR18-60
Outdoor Thermostat Kit w/ Lockout Stat	OT18-60A	OT18-60A
Outdoor Thermostat Kit (Used only with GPH1624M41 and GPH1630M41 models)	OTHPKG-01	N/A
Roof Curb	D14CRBPGCHMA	D14CRBPGCHMA

FOR THE GPH1660M41 UNITS**

DAIKIN MASTER ITEM #	DESCRIPTION
14CURB3672	14" Roof Curb
D25FD3672	25% Manual Fresh Air Damper
D25MFD3672	25% Motorized Fresh Air Damper
CDK4872	Concentric Duct Kit
DDNECNJ3672B	Low-leak Downflow Economizer
DDNECNJ3672NR	Downflow Economizer w/o Barometric Relief
DDNSQRD487218	Downflow Square-to-Round Adapter (18" Round)
DHZECNJ3672	Horizontal Economizer
DBRD3672	Barometric Relief Damper
EHK1-(10, 15, 20)	Electric Heat Kits
FSK01A	Freeze Stat Kit
GHRC-1	Hurricane Restraint Clips
LAKT01	Low-Ambient Kit

SINGLE-POINT KIT ACCESSORY KITS

Select the single-point kit accessory based on the unit model.

MODEL	SINGLE-POINT KIT
GPH1624M41**	SPK-30
GPH1630M41**	SPK-35
GPH1636M41**	SPK-40
GPH1642M41**	SPK-45
GPH1648M41**	SPK-50
GPH1660M41**	SPKT01/02

