

SWG Stainless Power Venter

Benefits of the SWG Power Venter include:

- 100% negative pressure in the vent pipe for maximum safety.
- Standard galvanized pipe can be used instead of expensive stainless steel.
- No need to seal vent pipe joints, saving time and money.
- Significantly longer vent lengths than positive pressure, direct vent systems.
- The SWG is recommended by major heating appliance manufacturers.

The SWG must be sized to match the appliance or appliances' input firing rate. Most firing rates are published in the manufacturer's installation manual. SWGs must be installed with a CK Control Kit to ensure proper listing and safe, efficient venting.



Replacement Motor Kit and Stainless Steel Model shown.

Note: SWG-4HD, 5 & 6 Motor Kits include a stainless steel blower wheel for better performance and extended life.

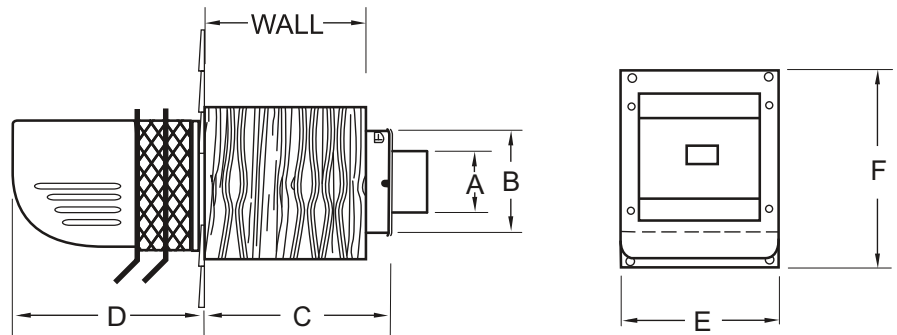

Specifications and Dimensions

Model	A	B	C	D	E	F
SWG-3	3"	5"	9 1/8"	8 1/2"	7 5/8"	9 3/16"
SWG-4HD	4"	6"	11 3/4"	9 1/2"	9"	9"
SWG-4HDs	4"	6"	11 3/4"	9 1/2"	11"	11 1/2"
SWG-5	5"	7"	11 3/4"	10 3/4"	12"	12 1/4"
SWG-5s	5"	7"	11 3/4"	10 1/2"	12"	12 1/2"
SWG-6	6"	8"	11 3/4"	10 3/4"	12"	12 1/4"
SWG-6s	6"	8"	11 3/4"	10 1/2"	12"	12 1/2"
SWG-8	8"	10"	11 3/4"	11 7/8"	13"	14 1/4"
SWG-10	10"	14"	19 1/2"	24"	20"	21"
SWG-12	12"	16"	19 1/2"	25"	22"	23"
SWG-14	14"	18"	19 1/2"	26"	24"	25"

NOTE: Control Kits are required for operation of the SWG. "s" Designates stainless steel model (recommended for oil applications).

Sizing The Power Venter

Size the Power Venter based on the input firing rate of the appliance. If the power venter is being used to vent multiple appliances, add the input firing rates for each appliance and use that total to size the venter. Knowing the total input GPH for oil, the venter can be sized from **Table 1**. Select the venter rated closest to the total input GPH for installation. If the input of the appliance is higher than the max allowable for that size Power Venter, move to the next larger size.

Do not select a venter with a maximum GPH lower than the appliance. The equivalent feet of vent pipe for the installation must be calculated. Based on the vent pipe diameter to be used, compare the calculated equivalent feet of vent pipe with the maximum equivalent feet allowable for the venter (**see Table 1**). If the calculated equivalent feet is greater than that allowed for the venter, increase the diameter of the vent pipe to be used and refer to the table or use the next larger size Power Venter.

SWG and ComboVent (CV)

Table 1 -Sizing The Venter (Use Maximum GPH Input)

MODEL	MAX* OIL GPH INPUT 100psi	MAX* OIL GPH INPUT 140psi	Maximum Equivalent Feet of Vent Pipe		VENT PIPE SIZE
			AT MAX GPH INPUT	AT 60% OF MAX GPH INPUT	
SWG-3	N/A	N/A	21	80	3"
			50	100	4"
SWG-4HD, 4HDs, CV-4	1.10	.90	35	100	4"
			65	100	5"
			100	100	6"
			100	100	7"
SWG-5, 5s, CV-5	1.85	1.55	16	44	4"
			51	100	5"
			95	100	6"
			100	100	7"
SWG-6, 6s	2.65	2.25	28	78	5"
			68	100	6"
			100	100	7"
SWG-8	4.75	4.0	26	72	7"
			51	100	8"
			70	100	9"
SWG-10	9	7.5	10	100	8"
			30	100	10"
			75	100	12"
SWG-12	13.5	11.5	16	100	10"
			40	100	12"
			86	100	14"
SWG-14	21	17.75	8	85	12"
			18	100	14"
			35	100	16"

* Select venter according to the actual rated maximum GPH input. ComboVent GPH ratings at 100 psi. Do not exceed maximum oil GPH input. For multiple venting system applications add the input for each. Unit sizing may vary depending on specific application. Consult your dealer or factory representative for the proper sizing for your particular application.

Note: In Table 1, the maximum equivalent footage allowable for the vent pipe is given for two points, the maximum GPH venting capacity and at 60% of the maximum. This allows for estimating values between the two given points.