

Wax Free Urinal Seal

Leak-Free, Hassle-Free, Worry-Free



ASTM A 1045



FUS BENEFITS & FEATURES

- Fast, easy installation that provides a long term solution - even **reusable on the same urinal** during service calls
- Strong, flexible adhesive creates a positive seal with the urinal
- Engineered to seal to the inside diameter of the drain pipe forming a water tight, gas tight and odor tight seal
- Made of flexible PVC and will flex with minor movement
- Will not absorb moisture or break down over time and is impervious to mold and mildew
- **Ideal for new installations and replacements**

Replace the failed foam seal **every time...**



...or install a Wax Free Urinal Seal **the first time!**



SCAN TO WATCH VIDEO

Part No.	Description
FUS-2	Wax Free Urinal Seal for 2" drain pipe

DIMENSIONS

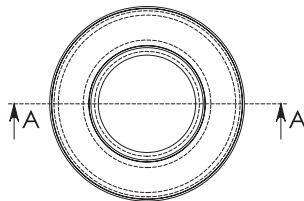
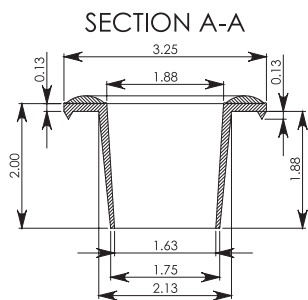

- Gasket Material: Plasticized PVC 75 Conforming to ASTM D 5926
- Adhesive: Permanent Pressure Sensitive Adhesive

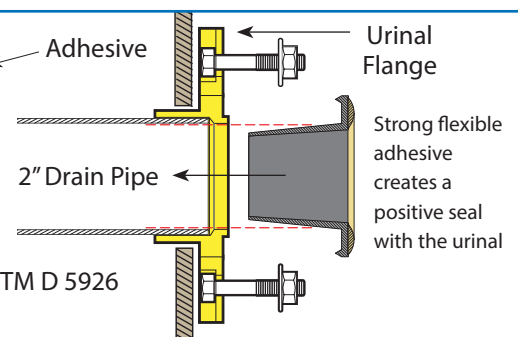

U.S. Patent Numbers: D655,796S; D655,795S; D655,400S; D649,625S