

SHR 1505R

Heat Recovery Ventilator

Product #: 40071



Fantech's side port connection HRV for house projects demanding a higher efficiency at very cold temperatures, the SHR 1505R unit brings a continuous supply of fresh air into a home while exhausting an equal amount of contaminated air. During winter, fresh incoming air is tempered by the heat that is transferred from the outgoing air so you save on energy costs, while during summer, the incoming air is pre-cooled if the house is equipped with an air cooling system. The SHR 1505R is equipped with automatic defrost mechanisms so you can use your HRV all year long.

Features

- Compact design
- Backward curved blade motors
- Electrostatic filters (washable)
- Aluminum heat recovery core
- External screw type dry contacts
- Improved core guide channels for easy removal of core
- Weighs 45 lbs (20Kg)

Accessories

- ECO-Touch™ (#44007) – Programmable Touch Screen Wall Control
- EDF1 (#40375) – Multi-function control
- EDF1R (#40393) – Triple function wall control
- RTS3 (#40376) – 20/40/60 minute over-ride
- RTS2 (#40164) – 20 minute over-ride
- MDEH1 (#40172) – Dehumidistat
- MDEH2 (#40173) – Mechanical low voltage dehumidistat with ON/OFF switch

Specifications

- Duct size – 6" (152 mm)
- Voltage/Phase – 120/1
- Power rated – 180 W
- Amp – 1.3 A
- Average airflow – 152 cfm (72 L/s)
@ 0.4" P_s (100Pa)

Motors

Two (2) factory-balanced motors with backward curved blades. Motors come with permanently lubricated, sealed ball-bearings to guarantee long life and maintenance-free operation. Covered by a seven year warranty.

Heat Recovery Core

Aluminum heat recovery core configured for efficient cross-flow ventilation. Core is 9" x 9" (229 x 229 mm) with a 15" (380 mm) depth. Cores are manufactured by Fantech to withstand extreme temperature variations.

Defrost

During the defrost sequence, a motorized damper temporarily blocks the incoming fresh air stream so that the warm air from the house can circulate through the HRV. The exhaust blower shuts down and the supply blower switches into high speed to maximize the effectiveness of the defrost strategy. During this cycle, household odors from the kitchen or bathroom are prevented from entering the home and the unit will not create negative pressure.

Serviceability

Core, filters, motors and drain pan can be easily serviced through latched access door located on front of the cabinet. Core conveniently slides out with ease on an improved railing system. Electrical box, placed on the outside of the unit, can also be easily accessed. 17" (432 mm) of clearance is recommended for removal of core.

Case

24 gauge galvanized steel. Baked powder coated paint.

Insulation

Cabinet is fully insulated with 1" (25 mm) high density expanded polystyrene.

Filters

Two (2) washable electrostatic panel type air filters 8.5" (216mm) x 15" (380 mm) x 0.125" (3mm).

Controls

External three (3) position (Low/Stand By/Medium) rocker switch that will offer continuous ventilation. In addition Fantech offers a variety of external controls.

Warranty

Limited lifetime on aluminum core, 7 year on motors, and 5 year on parts.

Dimensions & Airflow

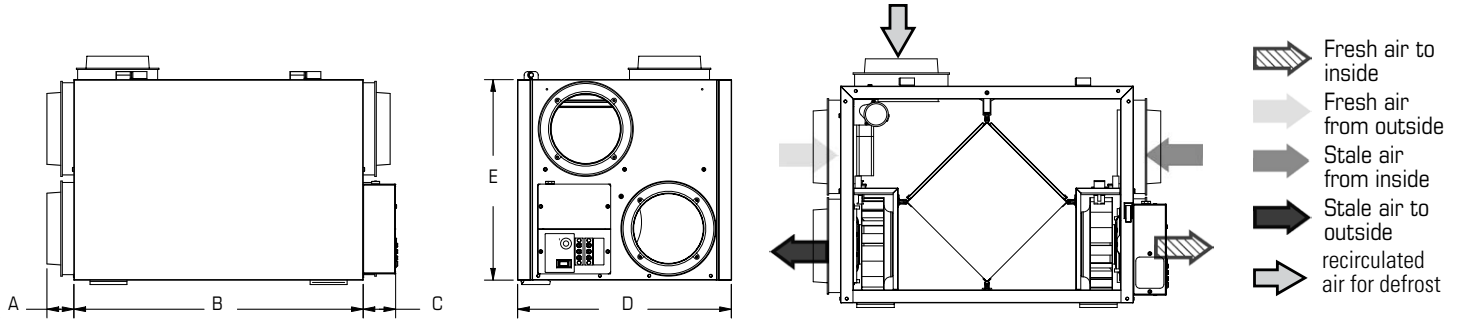

Model	A		B		C		D		E	
	in	mm	in	mm	in	mm	in	mm	in	mm

SHR1505R 2 1/4 57 23 1/2 597 2 5/8 67 17 3/8 441 17 3/8 441

Clearance of 17" (432mm) in front of the unit is recommended for removal of core. All units feature three foot plug-in power cord with 3-prong plug.

Ventilation Performance

in. wg. (Pa)	0.2 (50)	0.4 (100)	0.6 (150)	0.8 (200)	1.0 (250)
	cfm (L/s)	cfm (L/s)	cfm (L/s)	cfm (L/s)	cfm (L/s)
Net supply airflow	174 (82)	152 (71)	121 (57)	97 (46)	85 (40)
Gross supply airflow	178 (84)	156 (73)	125 (59)	97 (46)	85 (40)
Gross exhaust airflow	178 (84)	158 (74)	133 (63)	109 (51)	83 (39)

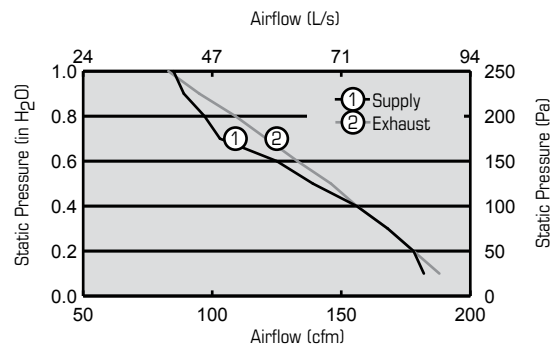

Energy performance

Heating	Supply temperature		Net airflow		Consumed power	Sensible recovery efficiency	Apparent sensible effectiveness	Latent recovery/moisture transfer
	°F	°C	cfm	L/s	W	%	%	-
	32	0	85	40	70	60	76	-0.02
	32	0	101	48	94	62	71	-0.02
	32	0	159	75	140	60	68	-0.01
	-13	-25	85	40	93	63	76	0.00

Requirements and standards

- Complies with the UL 1812 requirements regulating the construction and installation of Heat Recovery Ventilators
- Complies with the CSA C22.2 no. 113 Standard applicable to ventilators
- Complies with the CSA F326 requirements regulating the installation of Heat Recovery Ventilators
- Technical data was obtained from published results of test relating to CSA C439 Standards
- HVI certified

Contacts

Submitted by: _____	Date: _____
Quantity: _____ Model: _____	Project #: _____
Comments: _____	
Location: _____	
Architect: _____	
Engineer: _____	Contractor: _____

Distributed by:

United States 10048 Industrial Blvd. • Lenexa, KS 66061 • 1.800.747.1762 • www.fantech.net

Canada 50 Kanalfakt Way • Bouctouche, NB E4S 3M5 • 1.800.565.3548 • www.fantech.net

Fantech, reserves the right to modify, at any time and without notice, any or all of its products' features, designs, components and specifications to maintain their technological leadership position.

