



# Fantech

## SHR 14105R

### Light Commercial HRV



The Fantech SHR14105R is designed to provide an economical solution for high humidity applications such as indoor swimming pools, spas and fitness facilities. The higher humidity generation rate in these applications leads to annoying window condensation, mold and structure deterioration.

It's designed to reduce the occurrence of condensation in the indoor environment by first operating in recirculation mode, moving air around the structures, sweeping windows dry and eliminating troublesome cold spots, then switching to air exchange mode as needed. Air exchange mode simply exhausts humid air to the outside and replaces it with drier air from outside. The airstreams are separated by an energy efficient heat recovery core which uses the energy in the exhaust air to lower the load on the HVAC system. Automatic defrost and provisions for condensation are standard.

#### APPLICATIONS INCLUDE:

- Indoor Pools
- Spa's
- Health Centers
- Night Clubs
- Locker Room
- High humidity Applications

#### POWER & WEIGHT

- Volts 120V
- Amperage 10.6 Amps Total
- Weight 116 Kg (255 Lbs)
- Shipping Weight 134 Kg (295 Lbs)
- Blowers (x4) 115V, 60 Hz, 2.7 Amps
- Phase Single

Airflow Performance

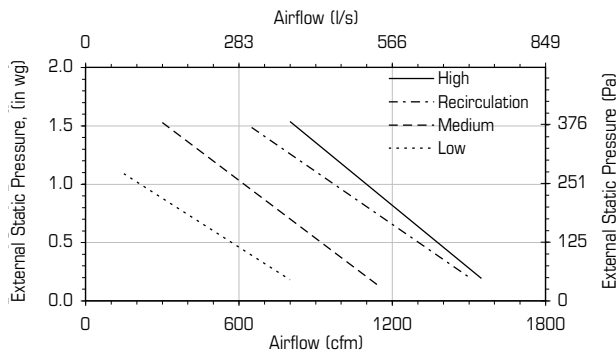

Thermal Effectiveness

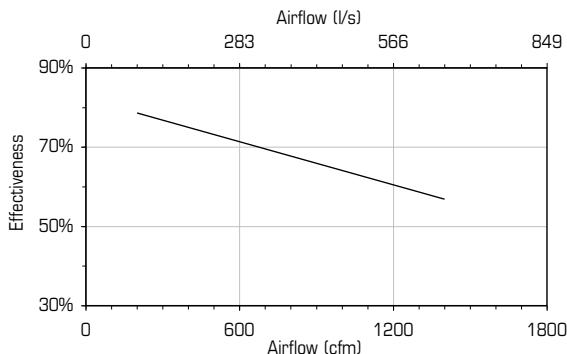

#### SPECIFICATIONS

**CASE** 20 gauge G90 galvanized steel coated with baked powder paint, insulated with 25mm (1 inch) and 50mm (2 inch) on outdoor air side foil-faced high density polystyrene foam for condensation control.

**BLOWERS** Four (4) maintenance-free Ebm-Papst™ backward inclined motorized impellers with permanently lubricated sealed ball bearings and (TOP) thermal overload protected.

**HEAT RECOVERY CORE** The Heat recovery Cores are fixed plate cross-flow heat exchanger using 1100 alloy aluminum and capable of transferring sensible heat between air streams. The heat recovery cores are engineered with a turbulence inducing geometry in order to maximize heat transfer while allowing an effective evacuation of condensate. The plates are hemmed to avoid cross-contamination of airstreams.

**FILTERS** The exhaust and fresh air streams are protected by MERV1 washable filters constructed to meet UL Class2. Optional MERV6 filters are direct replacement to the MERV1. Use of MERV6 filters will add an additional system pressure of 90 Pa (0.36in.wg) at 665 l/s (1410cfm).

**MOUNTING** Unit can be rod mounted or seated on a platform. Flanged connections are provided for suitable ductwork connections. Unit shall be adaptable for easy service of electrical components.

**CONTROLS** External three (3) position (Low/Standby/Medium) rocker switch that will offer continuous ventilation. Compatible with all Fantech HRV/ERV controls.

**FROST CONTROL** During the defrost sequence, a motorized damper temporarily blocks the incoming fresh air stream so that the warm air from the building can circulate through the HRV. The exhaust blower shuts down and the supply blower switches into high speed to maximize the effectiveness of the defrost strategy.

**SERVICEABILITY** Unit has hinged or screwed access panels on front and back. Cores, filters, motors and drain pan are serviceable from either sides of the unit. Fan assemblies are mounted on a removable sliding base. Heat recovery cores are mounted in slide-out rails for ease of inspection, removal and cleaning. Accessibility to the electrical box is maintained for any unit installation.



# SHR 14105R Light Commercial HRV

## Dimensions

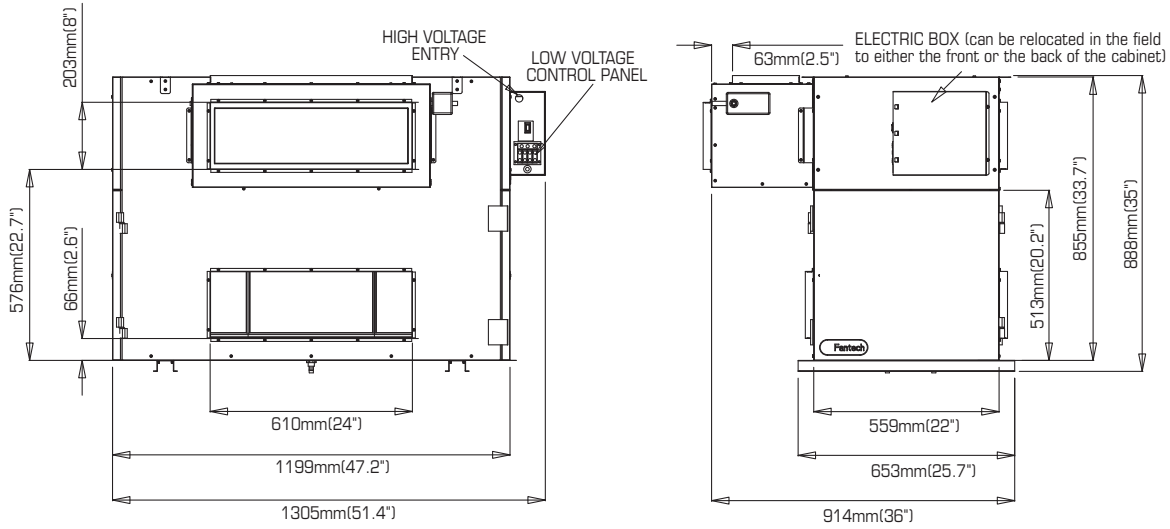

## PORT CONFIGURATION

The unit has access doors on the front and back. Also, the main control panel may be moved from front to back allowing for ducting layout.

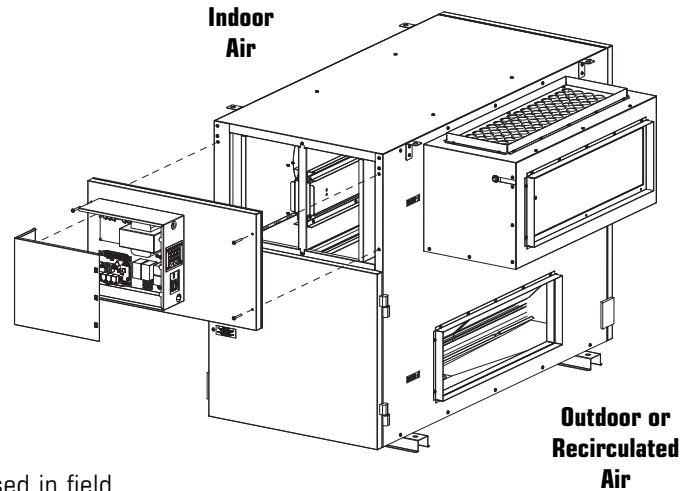
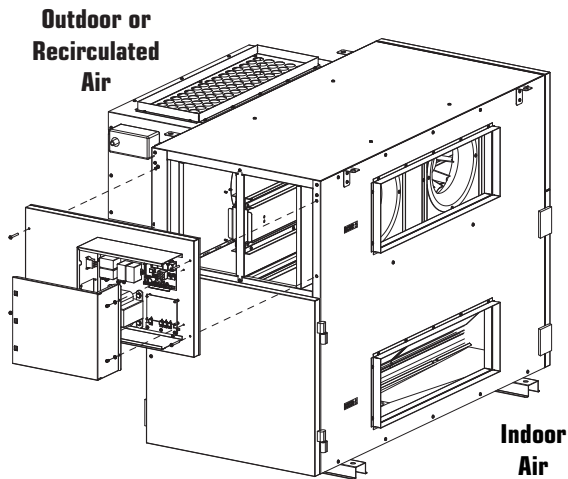

Factory Setting. Unit may be easily reversed in field

## Airflow

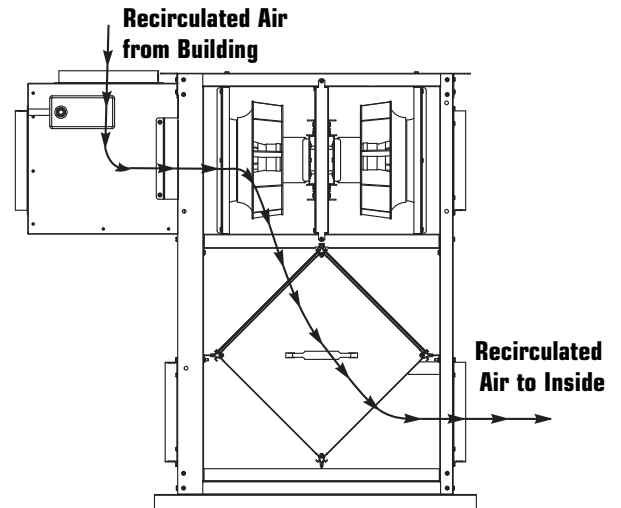
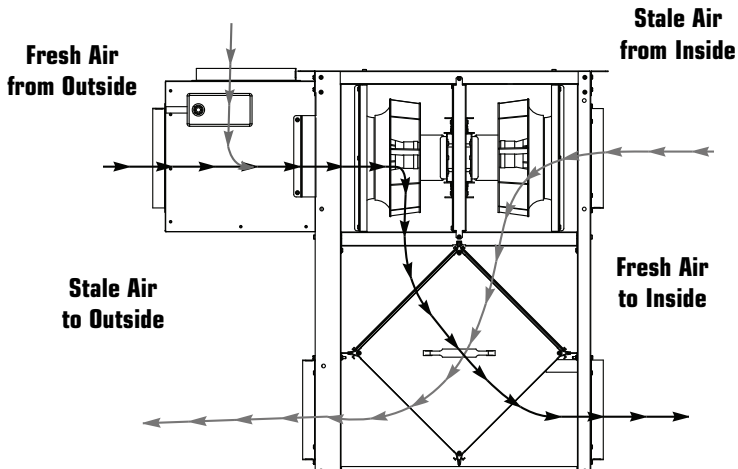

Fantech, reserves the right to modify, at any time and without notice, any or all of its products' features, designs, components and specifications to maintain their technological leadership position.

United States  
 10048 Industrial Blvd., Lenexa, KS. 66215  
 Phone: 800.747.1762; 913.752.6000 Fax: 800.487.9915; 913.752.6466  
[www.fantech.net](http://www.fantech.net); [info@fantech.net](mailto:info@fantech.net)

Canada  
 50 Kanalfakt Way, Bouctouche, NB E4S 3M5  
 Phone: 800.565.3548; 506.743.9500 Fax: 877.747.8116; 506.743.9600  
[www.fantech.net](http://www.fantech.net); [info@fantech.net](mailto:info@fantech.net)

Item #: 412660 • Rev Date: 092410