

PRODUCT SPECIFICATIONS

Elkay Fireclay 33" x 20" x 10-1/8" 60/40 Double Bowl Farmhouse Sink with Aqua Divide. Sink is molded from fine fireclay with a durable porcelain glaze providing a finish that is non-porous and resists staining. Naturally sound deadening and Center drain placement.

Installation Type:	Farmhouse
Material:	Fireclay
Special Features:	Aqua Divide
Finish:	Biscuit (BI), White (WH)
Number of Bowls:	2
Sink Dimensions:	33" x 20" x 10-1/8"
Bowl 1 Dimensions:	12" x 16-1/4" x 9-1/8"
Bowl 2 Dimensions:	18-3/8" x 16-1/4" x 9-1/8"
Drain Size:	3-1/2" (89mm)
Drain Location:	Center
Minimum Cabinet Size:	36"

Special Note: Sink is reversible offering the option of a traditional flat front or a decorative band feature

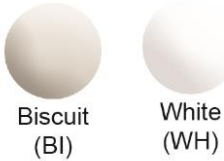

Installation Profile:

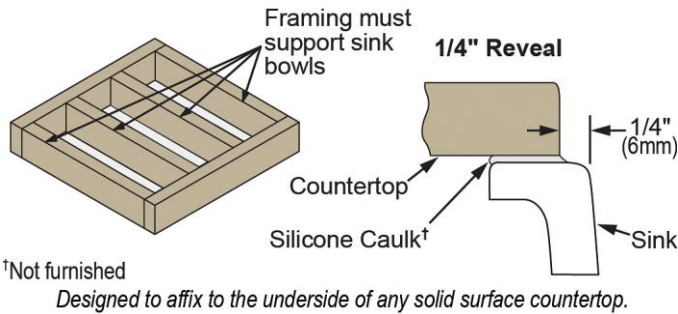

OPTIONAL ACCESSORIES

Drain:	LK99
Faucet:	LKEC2037



Included with Product: Walnut cutting board

AMERICAN PRIDE. A LIFETIME TRADITION. Like your family, the Elkay family has values and traditions that endure. For almost a century, Elkay has been a family-owned and operated company, providing thousands of jobs that support our families and communities.

Sinks are listed by IAPMO[®] as meeting the applicable requirements of the Uniform Plumbing Code[®], International Plumbing Code[®], and National Plumbing Code of Canada.

Product Compliance: ASME A112.19.2/CSA B45.1

- [Clean and Care Manual \(PDF\)](#)
- [Installation Instructions \(PDF\)](#)
- [Limited Lifetime Warranty \(PDF\)](#)

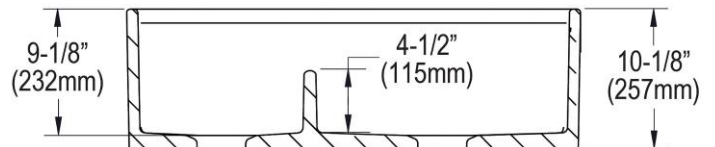
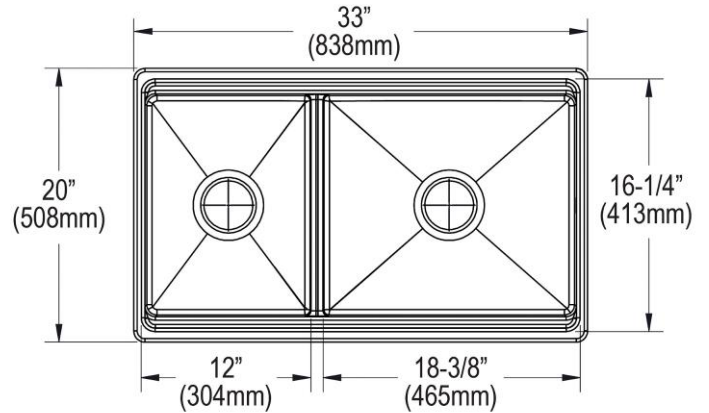

PART: _____ QTY: _____

PROJECT: _____

CONTACT: _____

DATE: _____

NOTES: _____

APPROVAL: _____

In keeping with our policy of continuing product improvement, Elkay reserves the right to change product specifications without notice. Please visit elkay.com for the most current version of Elkay product specification sheets. This specification describes an Elkay product with design, quality, and functional benefits to the user. When making a comparison of other producers' offerings, be certain these features are not overlooked.