

Submitted Model No.: _____

Specific Features: _____

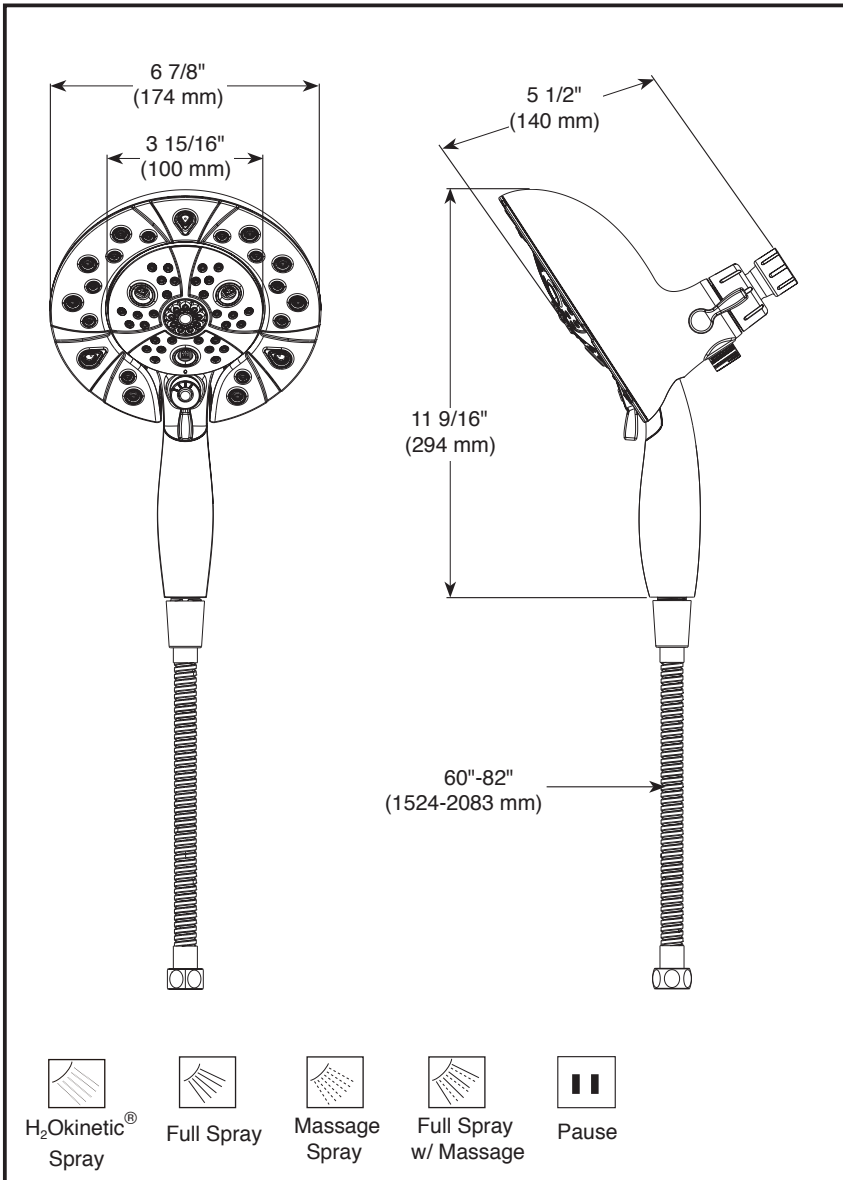

▲ Designate proper finish suffix

Delta reserves the right (1) to make changes in specifications and materials, and (2) to change or discontinue models, both without notice or obligation. Dimensions are for reference only. See current full-line price book or www.deltafaucet.com for finish options and product availability.

DSP-B-58480-PK Rev. B



IN2ITION®

- 2-In-1 shower
- 5-Spray Setting Handshower
- H₂Okinetic Technology® Handshower
- Magnetite Docking
- Touch-Clean® nozzles
- Certified Dual Check Valves

STANDARD SPECIFICATIONS:

- Maximum water consumption 2.0 gpm (7.6 L/min) @ 80 psi.
- Integrated handshower docks securely into showerhead when not in use.
- Multiple handshower spray settings.
- 3-Way diverter for extra spray options.
- Fixed showerhead and handshower all in one.
- Push-button pause control lever to change sprays, easy single-handed operation.
- 60-82" (1524-2083mm) stretchable metal hose.

WARRANTY

- Lifetime limited warranty on parts (other than electronic parts and batteries) and finishes; or, for commercial users, for 5 years from the date of purchase.
- 5 year limited warranty on electronic parts (other than batteries); or for commercial users, for 1 year from the date of purchase. No warranty is provided on batteries.



COMPLIES WITH:

- ASME A1 12.18.1 / CSA B125.1
- EPA WaterSense®



55 E. 111th Street, Indianapolis, Indiana 46280
350 South Edgeware Road, St. Thomas, Ontario Canada N5P 4L1
© 2015 Masco Corporation of Indiana