

GEOHERMAL

HWW Series Water-to-Water Systems

3 to 10 Tons

These flexible systems, available in 3, 5, and 10 ton capacities, have a wide range of HVAC and industrial applications. Units are used for such applications as radiant floors, snow/ice melting, chilled water for fan coils, potable hot water, and other types of residential or industrial applications that require cost-effective heated or chilled water. They can be installed using a ground loop, ground water or water loop (boiler/cooling tower) installation. As with all geothermal models, they offer the benefits of super high efficiency with low operating costs.



Flexibility is a hallmark of geothermal units. As reverse cycle heat pumps, 208/230V models can provide both hot and chilled water, as well as domestic hot water. All HWW units can be installed side by side for large capacity applications, thanks to compact size, single side service access, and water connections at the top of the unit.

With no outdoor fan, special mounting systems and 1/2" dual density acoustic type fiberglass cabinet insulation, operation is exceptionally quiet. A system performance monitor signals when the system is not running at peak performance so maintenance can be scheduled. Units come pre-charged with R-410A.



Exceeds
ASHRAE 90.1
efficiencies



FEATURES

- **Microprocessor Controls**—State-of-the-art controls include on-board diagnostics and seven standard “Safeties” including anti-short cycle, over- and under-voltage, loss of charge, high refrigerant pressure and more, to protect the unit and the compressor
- **Quiet Operation**—Double compressor mounting system and compressor compartment insulation minimize operating noise
- **Scroll Compressor**—Dependable design is proven efficient and quiet, with internally sprung and externally isolated vibration isolation system, including rubber grommet mounts
- **System Performance Monitoring**—Signals when the system is not running at peak performance so maintenance can be scheduled
- **Easy Service Access**—All components can be accessed through a front panel for maintenance and service; side panel can also be opened

PERFORMANCE DATA

AHRI/ISO/ASHRAE/ANSI 13256-2 Performance

Model	Water loop—BTUH				Ground Loop—BTUH				Shipping Wt. (lbs.)
	Cooling		Heating		Cooling		Heating		
	Indoor 53.6°F		Indoor 104°F		Indoor 53.6°F		Indoor 104°F		
	Outdoor 86°F		Outdoor 68°F		Outdoor 77°F		Outdoor 32°F		
	Cap. BTUH	EER	Cap. BTUH	COP	Cap. BTUH	EER	Cap. BTUH	COP	
HWW036A	33,000	14.6	44,000	5.0	34,000	16.8	28,000	3.1	373
HWW060B	52,800	14.3	72,700	4.7	55,600	16.2	48,500	3.0	385
HWW120B	105,600	14.1	145,400	4.6	111,200	16.0	97,000	3.0	770

Model	Ground Water—BTUH			
	Cooling		Heating	
	Indoor 53.6°F		Indoor 104°F	
	Outdoor 59°F		Outdoor 50°F	
	Cap. BTUH	EER	Cap. BTUH	COP
HWW036A	37,000	23.1	36,000	4.0
HWW060B	60,200	22.0	60,300	4.0
HWW120B	120,400	21.6	120,600	3.9

Limited Warranty—5 years on compressor, 1 year on parts
(Some limitations apply; see printed warranty for details.)

NOTES:

Units available in 208/230-1-60, 208/230-3-60, 460-3-60, and 575-3-60 (no HWW036).

208/230-1-60 models available with hot water generator with internal pump.



Unit Dimensional Data: HWW 036-120

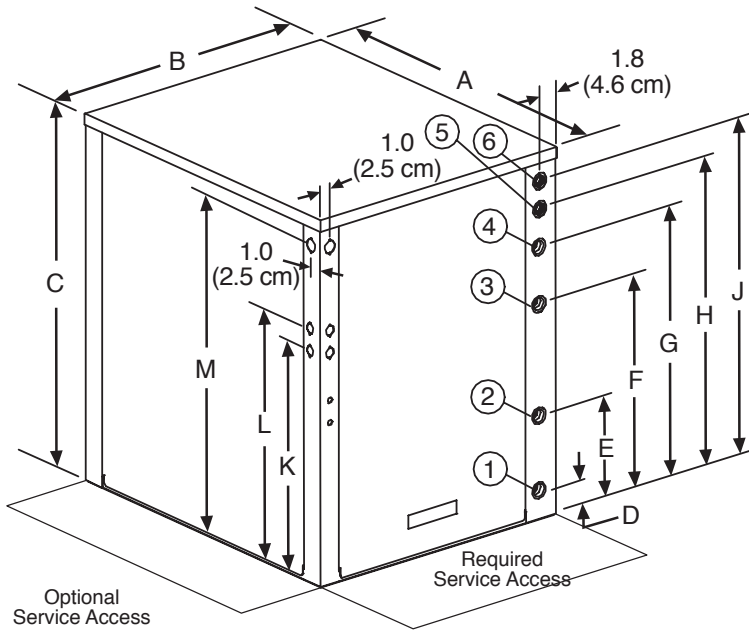

Notes:

1. Front & side access is preferred for service access. However, all components may be serviced from the front access panel if side access is not available.
2. While clear access to all removable panels is not required, installer should take care to comply with all building codes and allow adequate clearance for future field services.

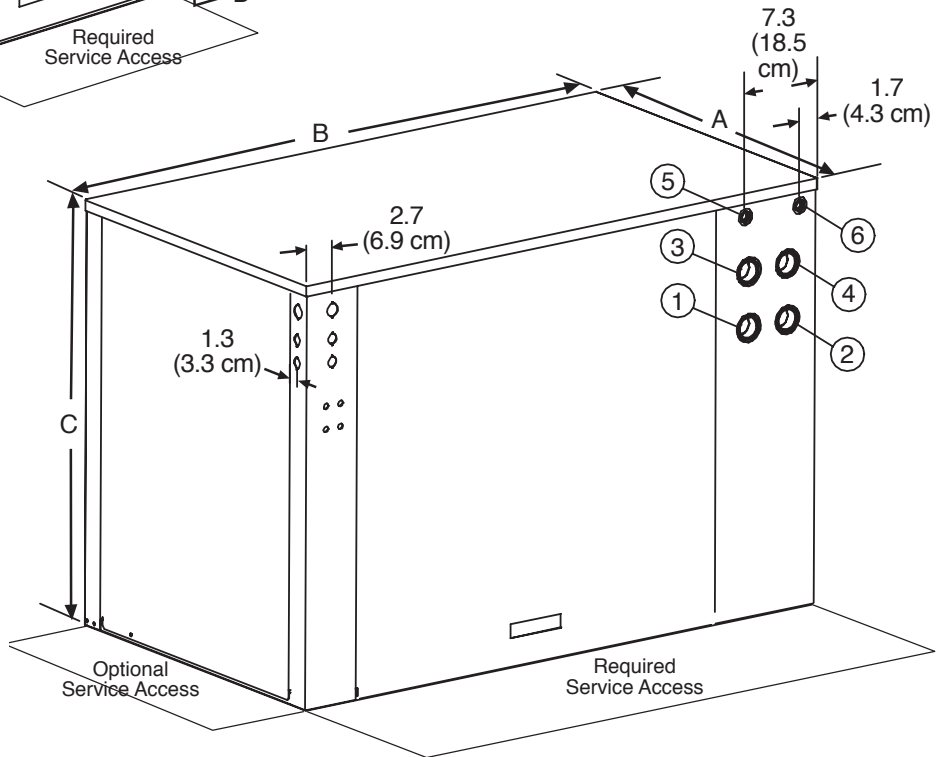

Water to Water	Overall Cabinet			Water Connections						Electric Access Plugs			
	A Depth	B Width	C Height	1	2	3	4	5	6	K Low Voltage	L External Pump	M Power Supply	
				D Source (Outdoor) Water In	E Source (Outdoor) Water Out	F Load (Indoor) Water In	G Load (Indoor) Water Out	H HWG Return In	J HWG Water Out				
036-060	in.	30.6	25.4	33	2.7	9.4	19.4	24.5	27.9	30.4	20.9	22.9	30.9
	cm.	77.8	64.5	83.8	6.9	23.9	49.3	62.2	70.9	77.2	53.1	58.2	78.5
120	in.	30.6	52.9	37	25.2	25.2	30.1	30.1	34.9	34.9	29.9	31.9	34.4
	cm.	77.8	134.4	94	64.0	64.0	76.5	76.5	88.6	88.6	75.9	81.0	87.4