

# Robertshaw®

RS2110  
RS2210

ECONOMY SERIES  
DIGITAL NON-PROGRAMMABLE  
THERMOSTATS



ELECTRIC



GAS



OIL



HEAT PUMP



MILLIVOLT  
RS2110 only

RS2110 – 1 Heat / 1 Cool

RS2210 – Multi-Stage 2 Heat / 1 Cool

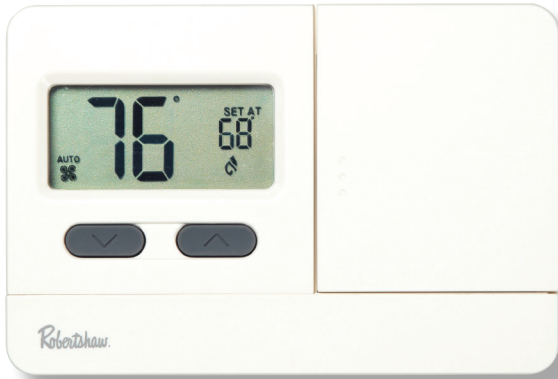

## Affordable Comfort Control

The Robertshaw® RS2000 thermostat family is *Simply The Right Choice™* when it comes to non-programmable temperature control.

With the comfort, convenience, and efficiency features that homeowners and contractors want, the RS2000 family provides value-packed thermostats for an economical price.

- New improved display makes it easy to read any time of the day.
- A fully adjustable temperature differential provides increased comfort control.
- The front load battery door makes it simple to replace the batteries.

All RS2000 thermostats are fully compatible with all standard 24V AC heating and cooling systems. Additional compatibility with multi-stage and heat pump systems are available in the RS2210 model.

Add in easy installation, expert technical service, and quality you can depend on, and the Robertshaw RS2000 thermostat family is *Simply The Right Choice.*

## Features and Benefits

### Multi-Stage 2 Heat / 1 Cool – RS2210 only

Operates on both multi-stage gas/electric furnaces and heat pumps to reduce inventory needed.

### New Improved Display

Makes viewing and setting the temperature easier.

### Adjustable Temperature Differential

Maintains optimal customer comfort.

### Worry-Free Memory Retention – RS2210 only

Maintains programmed parameters, even during power outages.

### Filter Monitor

Provides notice when filters need changing.

### Automatic Compressor Short Cycle Protection

Reduces wear and tear of HVAC equipment with this system safeguard.

### O and B Terminals

Provides greater system flexibility.

### Zone System Compatible

Acts as a sensor within the system.

### Quick Wire Terminal Block

Uses sturdy wire clamps – no wrap-around of screws for fast and easy installation.

An ISO 9001 – 2008 Certified Company

**2** Year  
Limited  
Warranty

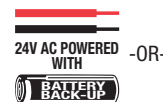

-OR-



## Terminal Designations

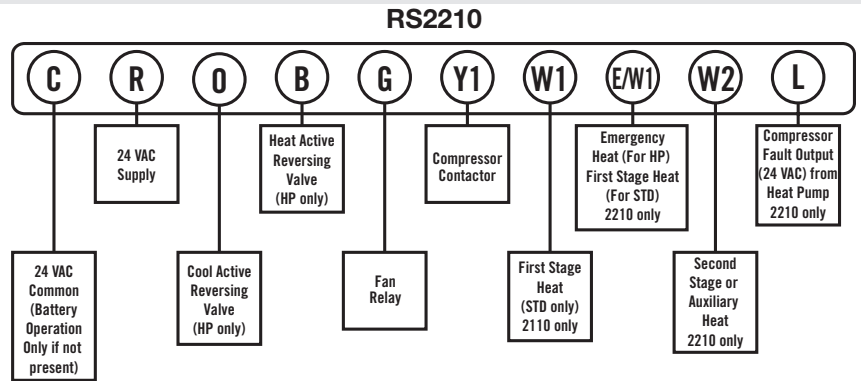
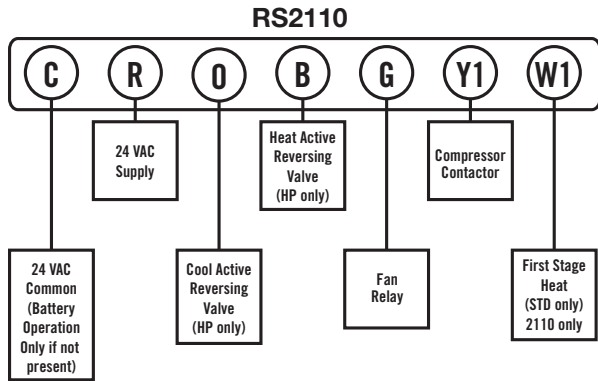

## Technical Specifications

<b>Product Weight</b>	10.4 oz.
<b>Electrical Rating</b>	24V AC (18-30V AC) 1 amp maximum load per terminal 3 amp total maximum load (all terminals combined)
<b>Temp. Control Range</b>	45°F to 90°F (7°C to 32°C)
<b>Accuracy</b>	± 1°F (± 0.5°C)
<b>Power</b>	24V AC with battery back-up OR 3V DC battery powered

**System Configurations** **RS2110** – Single stage electric, gas, oil or millivolt heating or heating/cooling systems including single stage heat pump systems. Not to be used with split transformer systems or 3-wire Hydronic (Hot Water) Zone Heat 110/220 Volts.

**RS2210** – Multi-stage electric, gas or oil heating or heating/cooling systems including multi-stage heat pump systems. Not to be used with split transformer systems or 3-wire Hydronic (Hot Water) Zone Heat 110/220 Volts.

**Terminations** **RS2110** – C, R, O, B, G, Y1, W1  
**RS2210** – C, R, O, B, G, Y1, W1, E/W1, W2, L

## Replacement Chart

RS2110	
Robertshaw®	8400, 8401
Braeburn®	1000, 1010, 1005NC, 1000TL, 1000NC
Lux	DMH110
Honeywell	TH1110D, TH8775C
White-Rodgers	1F78-144, 1F86-344
RS2210	
Robertshaw®	8425
Braeburn®	1100, 1210, 1200NC
Lux	DMP2110
Honeywell	TH1210D, T8411R, TH3210D
White-Rodgers	1F72-174

Verify specific application requirements before substitution.

## Shipping Specifications

Individual Carton Dimensions	6.75" x 4.375" x 1.625"
Master Carton Quantity	6
Master Carton Dimensions	9.25" x 5.625" x 7.625"
Master Carton Weight	4.2 lbs.