



Z1930

8 X 4 [203 X 102] A.R.C. SANI-FLOOR RECEPTOR 4 [102] SUMP DEPTH

SPECIFICATION SHEET

TAG _____

Dimensional Data (inches and [mm]) are Subject to Manufacturing Tolerances and Change Without Notice

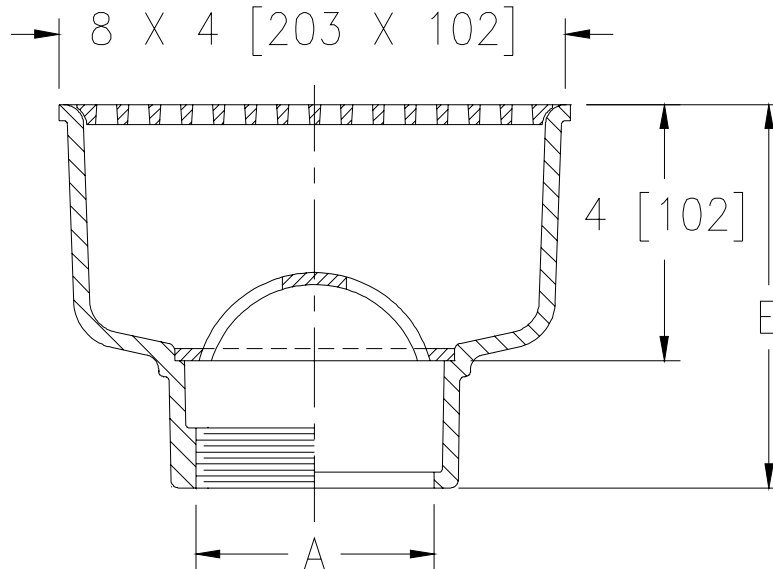

A- Pipe Size In.	Approx Wt. Lbs. [kg]	Grate Open Area Sq. In. [cm ²]
2-3 [51-76]	11 [5]	7.5 [48]

ENGINEERING SPECIFICATION: ZURN Z1930

Sani-Floor Receptor 8 x 4 x 4 [203 x 102 x 102] deep cast iron body and rectangular square hole light-duty grate, with white acid resisting epoxy coated interior and top, complete with white ABS anti-splash interior bottom dome strainer.

OPTIONS (Check/specify appropriate options)

PIPE SIZE

2-3 [51-76]
2-3 [51-76]
2-3 [51-76]

(Specify size/type) **OUTLET**

___ IC Inside Caulk
___ IP Threaded
___ NL Neo-Loc

'E' BODY HT. DIMENSION

Z	ZN
6 [152]	6-3/8 [162]
6 [152]	6-3/8 [162]
5-13/16 [148]	6-3/16 [157]

PREFIXES

___ Z Cast Iron Body with White A.R.C. Interior*
___ ZN Cast Iron Body with White A.R.C. Interior, 8-3/4 x 4-3/4 [222 x 121] N.B. Frame and Full Grate with 5/16 [8] Square Openings+
+Add 3/4 [19] to 8 [203] x 4 [102] Dimension

SUFFIXES

___ -K Anchor Flange	___ -7 Grate w/ 6-3/4 x 3 x 1 [171 x 76 x 25] High Oval Funnel
___ -KC Anchor Flange with Seepage Holes and Clamp Collar	___ -8 Grate w/ 8-7/8 x 3-5/8 x 3-3/4 [225 x 92 x 95] High Oval Funnel
___ -LD (Less) Bottom Dome Strainer	___ -11 Vandal-Proof Secured Grate (ZN Only)
___ -P 1/2 [13] Trap Primer Connection	___ -15 Solid Loose Set Cover (ZN Only)
___ -S Secondary Strainer	___ -16 1/2 Solid Loose Set Cover (ZN Only)
___ -TC Neo-Loc Test Cap Gasket (2-3 [51-76] NL Bottom Outlet Only)	___ -23 Aluminum Bucket
___ -1 (Less) Grate	___ -25 White A.R.C. Bucket
___ -2 1/2 Grate	___ -31 Stainless Steel Mesh Liner for Bucket
___ -3 3/4 Grate	___ -32 Aluminum Dome Strainer
___ -4 Full Grate with Square Center Opening	___ -33 White A.R.C. Anti-Splash Bottom Dome Strainer
___ -5 Grate w/ 4 [102] Dia. x 3-3/4 [95] High Funnel	
___ -6 Grate w/ 6 [102] Dia. x 6 [152] High Funnel	

REV. E DATE: 11/23/10 C.N. NO. 120515

DWG. NO. 59347

PRODUCT NO. Z1930

*REGULARLY FURNISHED UNLESS OTHERWISE SPECIFIED

ZURN INDUSTRIES, LLC. ♦ SPECIFICATION DRAINAGE OPERATION ♦ 1801 Pittsburgh Ave. ♦ Erie, PA 16514

Phone: 814/455-0921 ♦ Fax: 814/454-7929 ♦ World Wide Web: www.zurn.com

In Canada: ZURN INDUSTRIES LIMITED ♦ 3544 Nashua Drive ♦ Mississauga, Ontario L4V1L2 ♦ Phone: 905/405-8272 Fax: 905/405-1292