



Z1751

12 X 12 [305 X 305] SANI-FLOR RECEPTOR 8 [203] SUMP DEPTH

SPECIFICATION SHEET

TAG _____

Dimensional Data (inches and [mm]) are Subject to Manufacturing Tolerances and Change Without Notice

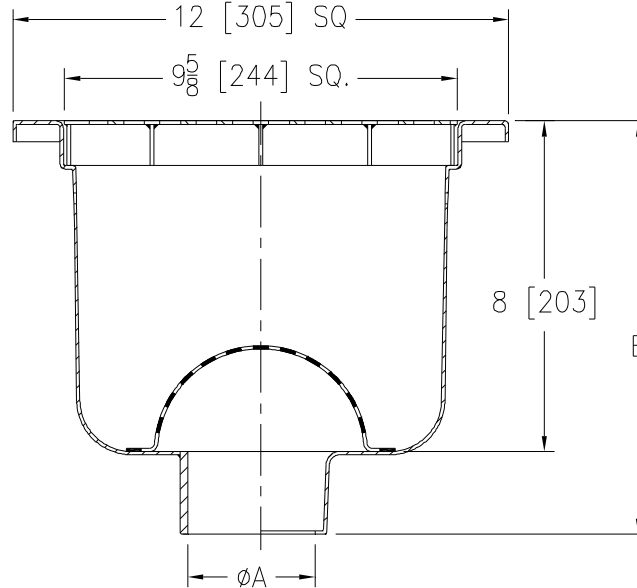

A- Pipe Size In.	Approx. Wt. Lbs. [kg]	Grate Open Area Sq. In. [cm ²]
2-3-4 [51-76-102]	19 [9]	23 [148]
6 [152]	21 [9]	23 [148]

ENGINEERING SPECIFICATION: ZURN Z1751

12 x 12 x 8 [305 x 305 x 203] deep, 16 gage, All Type 304 (CF8) Stainless Steel light-duty Sani-Flor receptor with non-tilt, loose set full grate with 1/2 [13] square openings and anti-splash stainless steel interior dome strainer.

OPTIONS (Check/specify appropriate options)

PIPE SIZE

- 2 thru 4 [51 thru 102]
- 2 [51]
- 3 [76]
- 4 [102]
- 2 thru 4, 6 [51 thru 102, 152]
- 2 thru 4 [51 thru 102]

(Specify size/type) **OUTLET**

- _____ IC Inside Caulk
- _____ IP Threaded
- _____ IP Threaded
- _____ IP Threaded
- _____ NH No-Hub
- _____ NL Neo-Loc

'E' BODY HT. DIM.

- 10-9/16 [268]
- 9-5/16 [237]
- 9-9/16 [243]
- 10-1/16 [256]
- 10-1/16 [256]
- 9-13/16 [249]

PREFIXES

- _____ Z Type 304 (CF8) Stainless Steel Body*
- _____ ZM Type 316 (CF8M) Stainless Steel

SUFFIXES

- | | |
|--|---|
| _____ -DX Dex-o-tex Flange | _____ -3 3/4 Grate |
| _____ -HD Extra Heavy-Duty Grate | _____ -4 Full Grate w/ 3 [76] Square Center Opening |
| _____ -HP Heel-Proof Grate | _____ -5 Grate w/ 4 [102] Dia. x 3-3/4 [95] High Type 304 Stainless Steel Funnel |
| _____ -K Anchor Flange | _____ -8 Grate w/ 8-3/8 x 3-5/8 x 3-3/4 [213 x 92 x 95] High Type 304 Stainless Steel Oval Funnel |
| _____ -KC Anchor Flange w/ Seepage Holes and Clamp Collar | _____ -15 Solid Cover |
| _____ -LSH (Less) Seepage Holes | _____ -16 1/2 Solid Cover |
| _____ -P 1/2 [13] Trap Primer Connection | _____ -17 3/4 Solid Cover |
| _____ -SG Solid Gasketed Cover | _____ -18 Solid Cover w/ 3 [76] Square Center Opening |
| _____ -TC Neo-Loc Test Cap Gasket (2 - 4 [51 - 102] NL Bottom Outlet Only) | _____ -19 Full Hinged Grate |
| _____ -VP Vandal-Proof Secured Top | _____ -20 Full Hinged Solid Cover |
| _____ -Y Sediment Bucket | |
| _____ -YS Suspended Sediment Bucket | |
| _____ -1 (Less) Grate | |
| _____ -2 1/2 Grate | |

*REGULARLY FURNISHED UNLESS OTHERWISE SPECIFIED

REV. J	DATE: 11/18/10	C.N. NO. 120404
DWG. NO. 59306		PRODUCT NO. Z1751

ZURN INDUSTRIES, LLC ♦ SPECIFICATION DRAINAGE OPERATION ♦ 1801 Pittsburgh Ave. ♦ Erie, PA 16514

Phone: 814455-0921 ♦ Fax: 814454-7929 ♦ World Wide Web: www.zurn.com

In Canada: ZURN INDUSTRIES LIMITED ♦ 3544 Nashua Drive ♦ Mississauga, Ontario L4V1L2 ♦ Phone: 905405-8272 Fax: 905405-1292