

Dimensional Data (inches and [ mm ]) are Subject to Manufacturing Tolerances and Change Without Notice

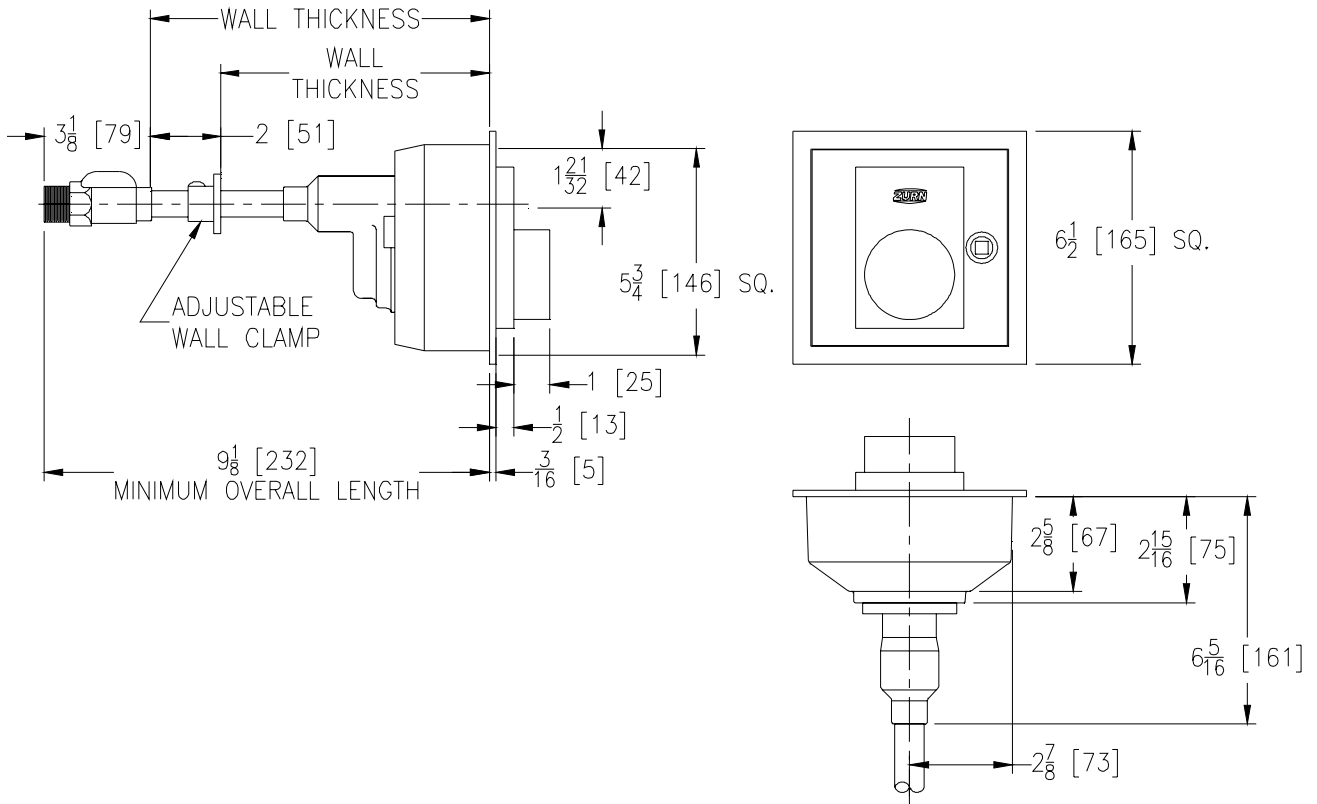

Wall Thickness In Inches	Approx. Wt. Lbs. [kg]
6-8 [152-203]	5 [2]
10-12-14-16 [254-305-356-406]	6 [3]
18-20-22-24 [457-508-559-610]	8 [4]

**ENGINEERING SPECIFICATION:** Z1320-C-BFP Encased Ecolotrol, anti-siphon, automatic draining, non-freeze wall hydrant complete with hose connection backflow preventer, copper casing, all bronze interior parts, non-turning operating rod with free-floating compression closure valve, and combination 3/4 [19] female solder and 3/4 [19] male pipe thread inlet connection standard. Regularly furnished with 3/4 [19] hose connection. Chrome-plated rough cast bronze box and hinged cover. Includes operating key.

**OPTIONS** (Check/specify appropriate options)

**SUFFIXES**

- \_\_\_ -34EL 3/4 [19] 90° Solder Inlet Elbow
- \_\_\_ -CL Cylinder Lock
- \_\_\_ -DU Combination 3/4 [19] Female Pipe Thread and 1 [25] Male Pipe Thread Connection
- \_\_\_ -NB Polished Nickel Bronze Finish
- \_\_\_ -PB Polished Bronze Finish
- \_\_\_ -RA2 12 [305] Wall Rod Assembly with Repair Kit (-RK)
- \_\_\_ -RA4 24 [610] Wall Rod Assembly with Repair Kit (-RK)
- \_\_\_ -RK Hydrant Parts Repair Kit
- \_\_\_ -SS Stainless Steel Finish
- \_\_\_ -WC Wall Clamp



1019-A