



Z1209-ND4-F

SPECIFICATION SHEET

VERTICAL OFFSET BACK-TO-BACK SIPHON JET SUPPORT SYSTEM FOR FLOOR-MOUNTED BACK OUTLET FIXTURES

TAG _____

Dimensional Data (inches and [mm]) are Subject to Manufacturing Tolerances and Change Without Notice

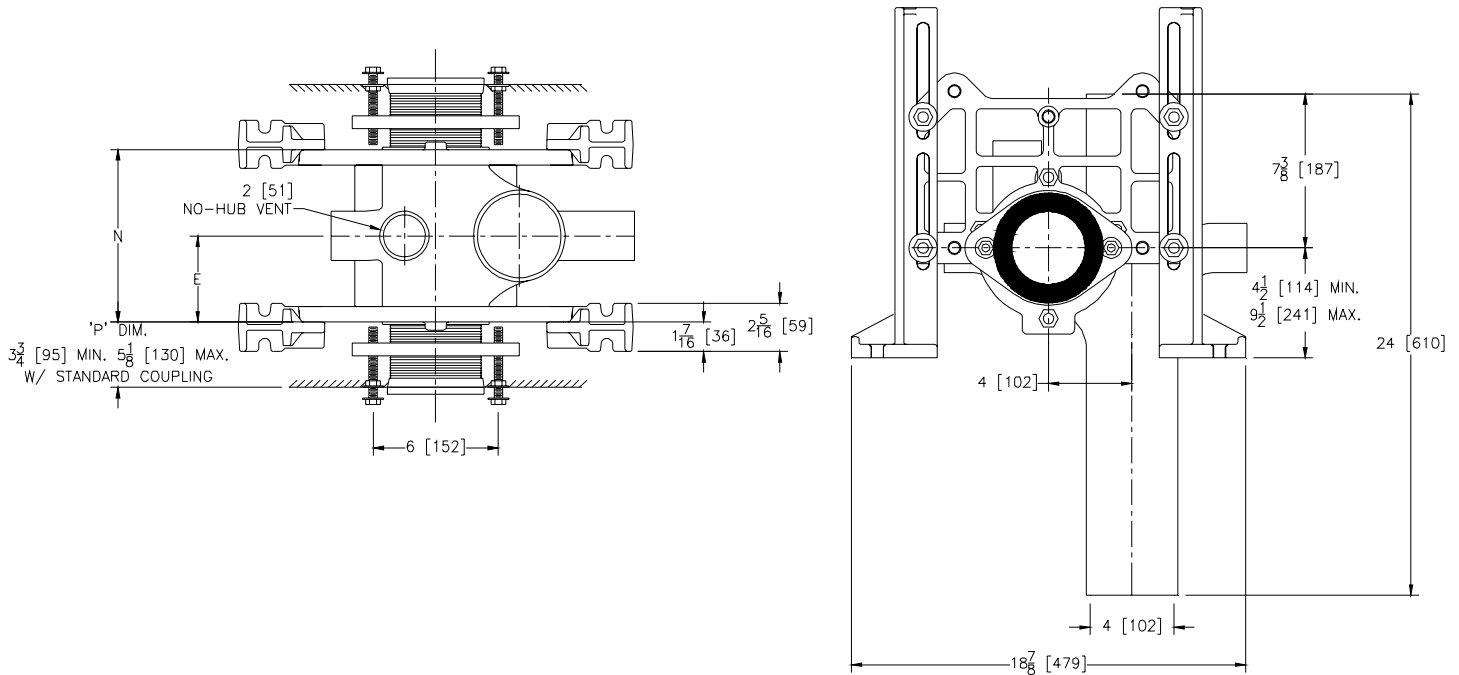

NOTE:

1. Min. 'P' dim. obtainable = 1-1/4 [32]
2. Feet bolted to floor using min. Ø1/2 [13] anchors and back slots on carrier feet.

ENGINEERING SPECIFICATION: ZURN Z1209-ND4

Back-to-back vertical offset siphon jet water closet "Rigid System" with 4 [102] size no-hub or hub and spigot connections and 2 [51] vent. Complete with dura-coated cast iron main fitting, separable faceplates rigidly mounted on fitting, universal floor mounted foot supports, corrosion resistant adjustable ABS coupling with integral test cap, fixture trim, stud protectors, bonded "Neo-Seal" gasket, and back outlet fixture supports.

Product No.	Dim. in Inches		Approx. Wt. Lbs.
	E	N	
Z1209-ND4/-HD4	4-1/8 [105]	8-1/4 [210]	110 [50]

OPTIONS (Check/specify appropriate options)

- ___ Z1209-ND4 4 [102] No-Hub Stack, Double Inlet, 2 [51] Vent
- ___ Z1209-HD4 4 [102] Hub and Spigot Stack, Double Inlet, 2 [51] Vent

PREFIXES

- ___ Z D.C.C.I. System with Zurn "ZZ" Adjustable Coupling*
- ___ ZQ D.C.C.I. System with N.P.T. Non-Adjustable Coupling

SUFFIXES

- | | |
|---|---|
| <ul style="list-style-type: none"> ___ -A Auxiliary Support Assembly (For P-Dim. greater than 18 [457]) ___ -CC Corrosion Resistant Cast Iron Coupling (6 [152] to 12 [305]) ___ -CL Coupling Length Greater than 12 [305] (specify length required) ___ -G Galvanized Cast Iron ___ -JJ Two 2 [51] Auxiliary Inlets ___ -JS 2 [51] Stack Side Auxiliary Inlet ___ -JV 2 [51] Vent Side Auxiliary Inlet ___ -M Auxiliary Foot Support (For P-Dim. 10 [254] -18 [457]) | <ul style="list-style-type: none"> ___ -RYK Unistrut Pre-Fab Foot ___ -VP Vandal Proof Trim ___ -29 Mechanical Test Cap Assembly ___ -50 Flush Valve Supply Support for Water Closets ___ -61 "ZZ" Coupling Wrench |
|---|---|

*REGULARLY FURNISHED UNLESS OTHERWISE SPECIFIED

REV. A	DATE: 09/26/11	C.N. NO. 122204
DWG. NO. 301271 PRODUCT NO. Z1209-ND4		

ZURN INDUSTRIES, LLC ♦ SPECIFICATION DRAINAGE OPERATION ♦ 1801 Pittsburgh Ave. ♦ Erie, PA 16514

Phone: 814/455-0921 ♦ Fax: 814/454-7929 ♦ World Wide Web: www.zurn.com

In Canada: ZURN INDUSTRIES LIMITED ♦ 3544 Nashua Drive ♦ Mississauga, Ontario L4V1L2 ♦ Phone: 905/405-8272 Fax: 905/405-1292