



# Z-1024

## FIXED AIR GAP

SPECIFICATION SHEET

TAG \_\_\_\_\_

Dimensional Data (inches and [ mm ]) are Subject to Manufacturing Tolerances and Change Without Notice

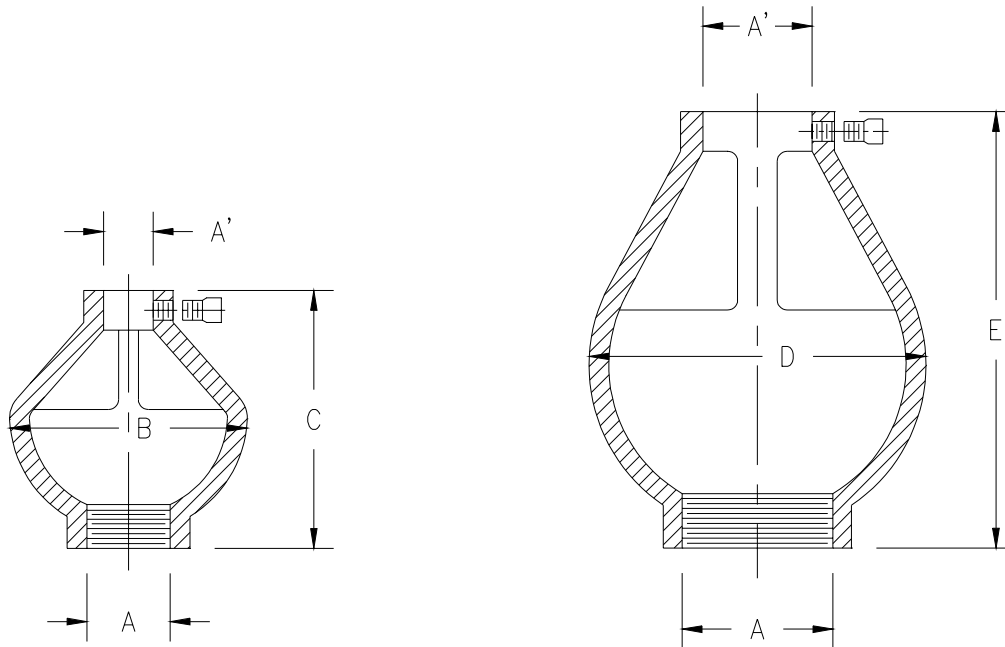

Product Designation	Dimensions In Inches					Approx. Wt. Lbs. [kg]
	Pipe Size	B	C	D	E	
	A' x A SJ x N.P.T.					
-1	1/4 X 3/4 [6 X 19]	3[76]	3 1/4 [83]	—	—	1[.5]
-2	1/2 X 3/4 [13 X 19]	—	—	4 1/4 [108]	5 1/2[140]	3[1]
-3	1/2 X 1 [13 X 25]	—	—	4 1/4 [108]	5 1/2[140]	3[1]
-4	3/4 X 1 1/2 [19 X 38]	—	—	4 1/4 [108]	5 1/2[140]	3[1]
-5	1 X 1 1/2 [25 X 38]	—	—	4 1/4 [108]	5 1/2[140]	3[1]

**ENGINEERING SPECIFICATION:** ZURN Z-1024 Fixed Air Gap, Dura-Coated cast iron with slip joint inlet and N.P.T. outlet.

**CONNECTIONS** (Check/specify appropriate options)

**PIPE SIZE**

(Specify size/type) **CONNECTION**

See Chart

\_\_\_\_\_ SJ X N.P.T. Slip Joint x N.P.T.

**PREFIXES**

\_\_\_\_\_ Z- D.C.C.I.\*  
 \_\_\_\_\_ ZARB- All Plain Bronze

**SUFFIXES**

\_\_\_\_\_ -G Galvanized Cast Iron

REV.	DATE: 2/24/97	C.N. NO. 77049
DWG. NO. 61451	PRODUCT NO. Z-1024	

\*REGULARLY FURNISHED UNLESS OTHERWISE SPECIFIED