

"QUALITY PUMPS SINCE 1939"

Product information presented here reflects conditions at time of publication. Consult factory regarding discrepancies or inconsistencies.

**ZOELLER**  
PUMP CO.



SECTION: 2.50.045

FM2190

0311

Supersedes

1007

MAIL TO: P.O. BOX 16347 • Louisville, KY 40256-0347  
SHIP TO: 3649 Cane Run Road • Louisville, KY 40211-1961  
(502) 778-2731 • 1 (800) 928-PUMP • FAX (502) 774-3624

visit our web site:  
[www.zoeller.com](http://www.zoeller.com)

# THE SHARK

Series

## 841 & 842 GRINDER PUMPS

### FEATURES:

- Finned Class 30 Cast Iron Construction.
- Corrosion Resistant Powder Coated Epoxy Finish.
- Discharge Size - 1 1/4" NPT.
- 2 HP, 60 Hz, 3450 RPM.
- 20 ft. Cord Length.
- Oil-Filled - Hermetically Sealed Motor with Class F Windings.
- Hardened Stainless Steel Cutter and Disc, Rockwell C55-60.
- Cutters Protected from Abrasive Solids.
- Bronze Vortex Impeller.
- Upper and Lower Ball Bearing Construction.
- Stainless Steel Screws, Bolts, and Lifting Bail.
- Easily adapts to many existing competitors' rail systems.
- Dual mechanical seals with leak detection.
- Automatic Thermal Overload Protection (Single Phase)
- Thermal Sensor Protection (Standard on 3 Phase)
- Legs provide for free standing installation.
- Preassembled Systems Available.
- cCSAus Certified
- 135 lbs.

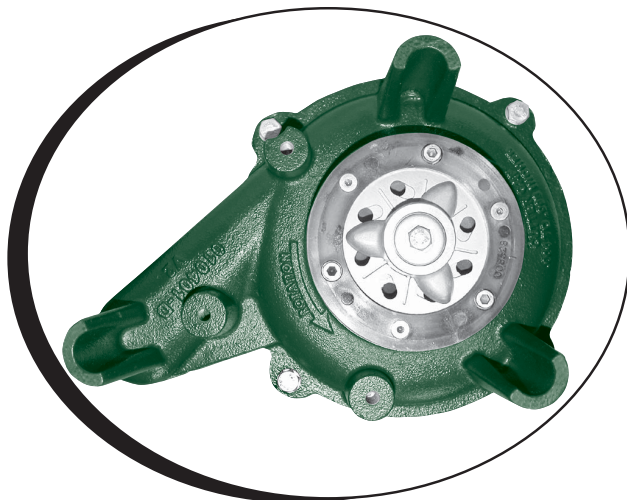

## 841-842 SERIES

841 - 2 HP

842 - 2 HP

SINGLE DIRECTIONAL  
GRINDER PUMPS



Tested to UL Standard UL778  
& Certified to CSA  
Standard C22.2 No. 108

Non-Automatic  
Non-Reversing  
1 1/4" NPT Discharge



Product may not be exactly as pictured.

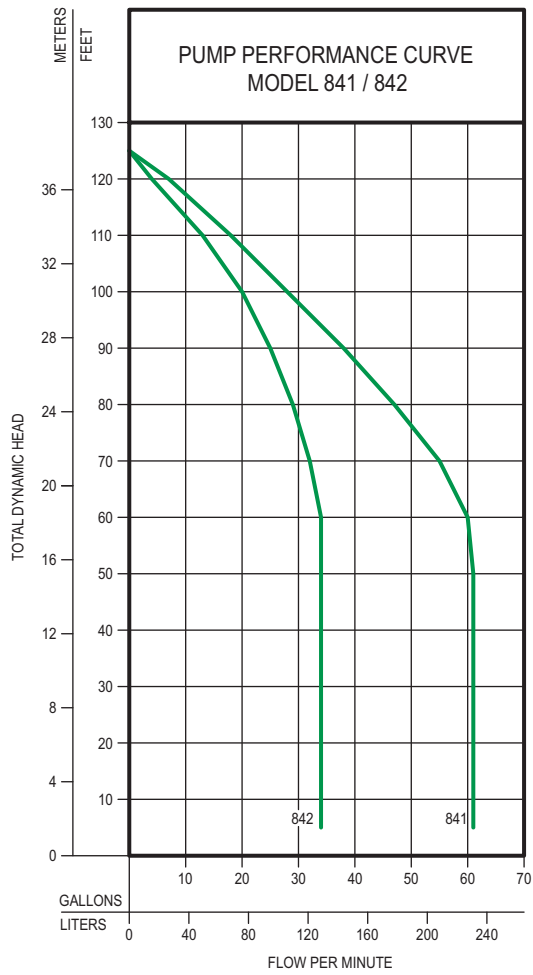

**TOTAL DYNAMIC HEAD/FLOW  
PER MINUTE  
SEWAGE**

MODEL		841		842	
Feet	Meters	Gal.	Liters	Gal.	Liters
5	1.5	61	231	34	129
10	3.0	61	231	34	129
20	6.1	61	231	34	129
30	9.1	61	231	34	129
40	12.2	61	231	34	129
50	15.2	61	231	34	129
60	18.3	60	227	34	129
70	21.3	55	208	32	121
80	24.4	47	178	29	110
90	27.4	38	144	25	95
100	30.5	28	106	20	76
110	33.5	18	68	13	49
120	36.6	7	26	4	15
Shut-off Head:		125 ft (38.1 m)		125 ft (38.1 m)	

019332

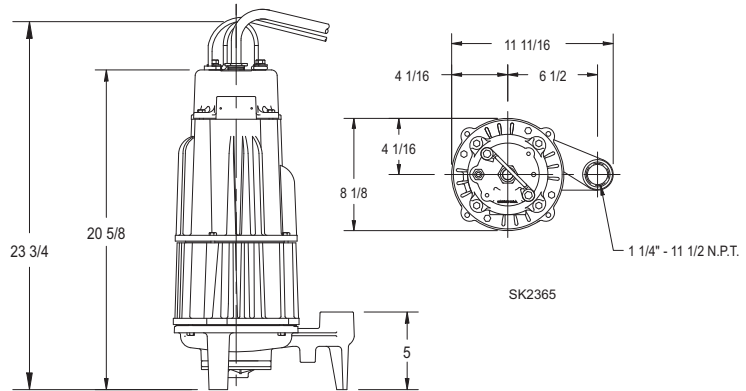

**Packaged & Field Assembled Systems**

Refer to FM1232 for Basin Assemblies and Accessories that can be used with the model 841 or 842.

**Electrical Data and Control Panel Selections**

Models	Part Number	Volts	Phase	HP	Amps	*Start Pak	**NEMA 4X Control Panels	
							Simplex	Duplex
I841	841-0005	200	1	2	20.0	10-0380	10-1650	10-1652
E841	841-0004	230	1	2	17.2	10-0380	10-1650	10-1652
J841	841-0006	200	3	2	12.3	Not Required	10-1097	10-1125
F841	841-0007	230	3	2	10.8	Not Required	10-1097	10-1125
G841	841-0008	460	3	2	5.5	Not Required	10-1094	10-1122
BA841	841-0009	575	3	2	4.5	Not Required	10-1146	10-1168
I842	842-0005	200	1	2	20.0	10-0380	10-1650	10-1652
E842	842-0004	230	1	2	17.2	10-0380	10-1650	10-1652
J842	842-0006	200	3	2	12.3	Not Required	10-1097	10-1125
F842	842-0007	230	3	2	10.8	Not Required	10-1097	10-1125
G842	842-0008	460	3	2	5.5	Not Required	10-1094	10-1122
BA842	842-0009	575	3	2	4.5	Not Required	10-1146	10-1168

\* Capacitors and Start Relay are shipped loose for Field Installation.

\*\* Control Panels include Seal Leak Indication, Visual and Audible High Water Alarm and Dry Contacts. Single Phase Control Panels include Capacitors and Start Relay.