

# Corina

VitrA



<b>Description</b>	: Corina two-piece elongated Front Bowl, extended height, ADA Compliant
<b>Model Number</b>	: 5232-XXX-0075
<b>Compatible item</b>	: 5398-XXX-5320 Tank with polished chrome metal trim lever on left hand side (14" rough-in) 5398-XXX-5326 Tank with polished chrome metal trim lever on right hand side (14" rough-in) 5398-XXX-5182 Tank with white plastic trim lever on left hand side (14" rough-in) 5398-XXX-5285 Tank with white plastic trim lever on right hand side (14" rough-in) 36-XXX-002 Toilet seat elongated (available only in white color) 44-XXX-009 Toilet seat elongated, soft closing
<b>Water Consumption</b>	: 1.6 GPF
<b>Water Surface</b>	: 8 7/8" x 8 1/8"
<b>Water Depth From Rim Rough-In</b>	: 6 3/4"
<b>Minimum Water Pressure</b>	: 20 psi.
<b>Trap Diameter</b>	: Fully glazed 2" ball pass with 2" trap diameter
<b>Trap Seal Depth</b>	: 2 3/8"
<b>Shipping Weight</b>	: 5232: 53 lbs. 5398: 51 lbs.
<b>Shipping Dimensions</b>	: 5232: 15 1/8" W X 28 6/8" L X 18 7/8" H 5398: 19 7/8" W X 11 3/8" L X 16" H
<b>Installation Guide</b>	: VitrA Guide 312851
<b>Included components</b>	: Tank fittings, bolt caps (white 310359 / bone-biscuit 310306)
<b>Material</b>	: Vitreous china
<b>Colors</b>	: 003 White 017 Bone, 068 Biscuit (Basic Colors) "XXX" indicates the color Meets the American Disabilities Act Guidelines and
<b>Standards</b>	: ICC/ANSI A117-1 requirements when installed so top of seat is 17" from the finished floor. Recommended seat for ADA requirements: VitrA 36-XXX-002 ASME A 112.19.2, CSA B45, ADA ICC/ANSI A117-1, LADWP/SPS (City of Los Angeles)
<b>Warranty</b>	: 10 year limited warranty

1

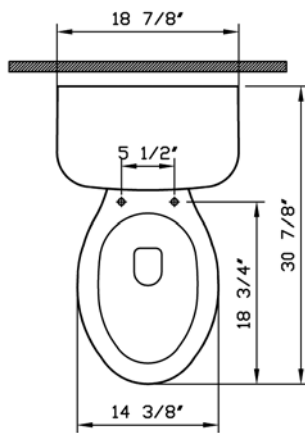

2

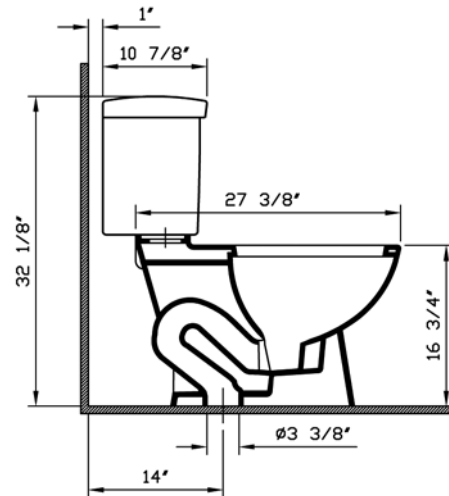

3

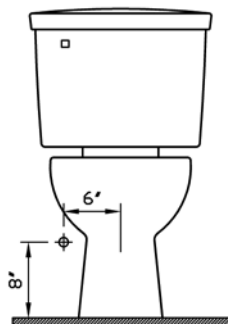

**Notes:**

- DIMENSIONS SHOWN FOR THE LOCATION OF THE SUPPLY IS SUGGESTED.
- INSTALLATION INSTRUCTIONS SUPPLIED WITH THE TOILET.

**IMPORTANT:** Dimensions of fixtures are nominal and may vary within the range of tolerances established by ASME Standard A 112.19.2, CSA Standard B45. These measurements may be subject to change. No responsibility is assumed for the use of superseded or voided pages.

August, 2008