



**T&S BRASS AND BRONZE WORKS, INC.**

2 Saddleback Cove / P.O. Box 1088  
Travelers Rest, SC 29690

Model No.

**B-2742**

Item No.

Travelers Rest, SC: 800-476-4103 • Simi Valley, CA: 800-423-0150 • Fax: 864-834-3518 • www.tsbrass.com

This Space for Architect/Engineer Approval

Job Name \_\_\_\_\_ Date \_\_\_\_\_

Model Specified \_\_\_\_\_ Quantity \_\_\_\_\_

Customer/Wholesaler \_\_\_\_\_

Contractor \_\_\_\_\_

Architect/Engineer \_\_\_\_\_



**ADA Compliant**

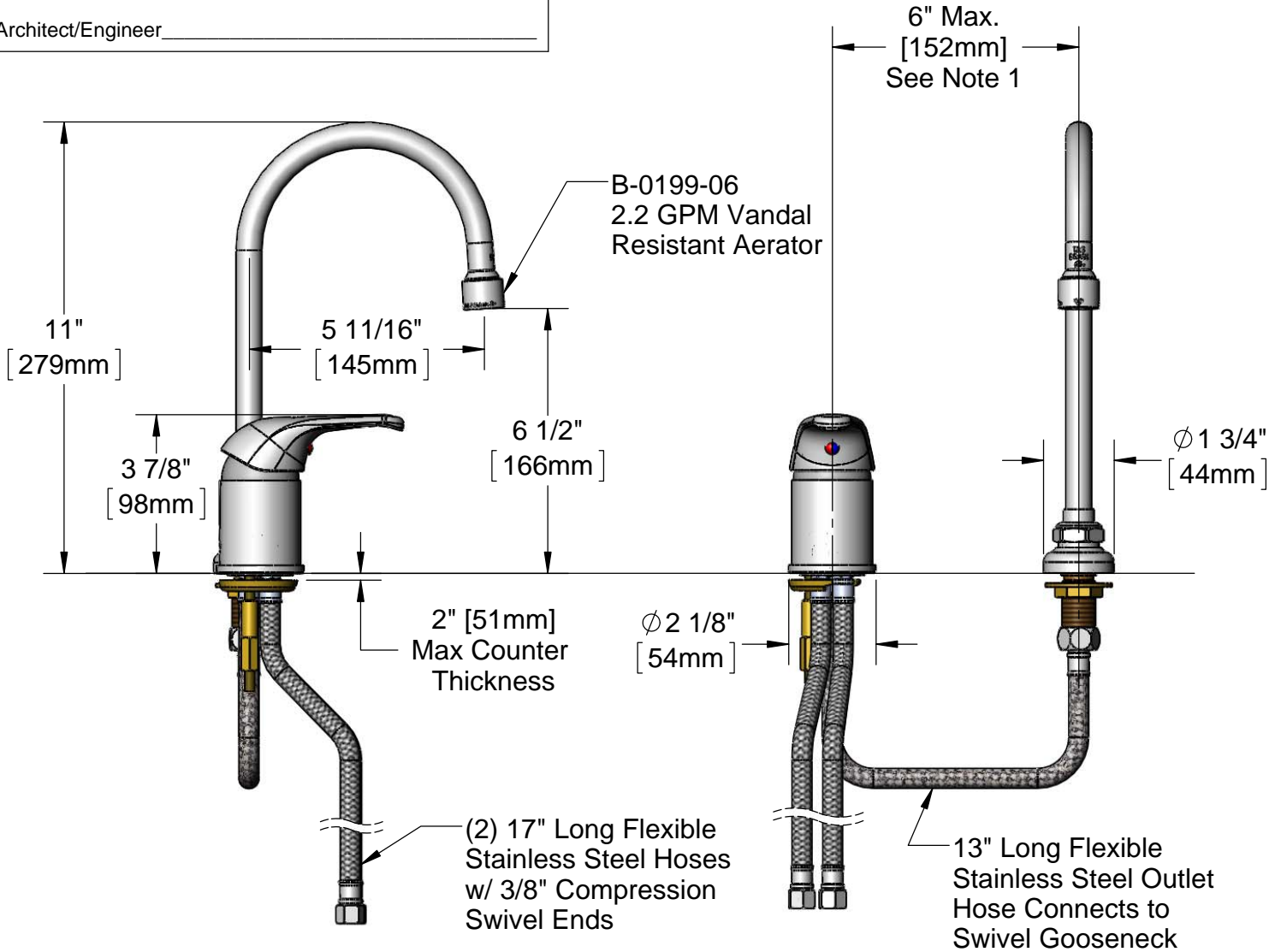

**Rough-in Requirements:**

- Ø 1 1/2" [38mm] Hole for Sidemount
- Ø 1" [25mm] Hole for Gooseneck Shank

**Notes:**

- Flex hose may kink if 6" Max is exceeded.

**Product Specifications:**

Side Mount Faucet, Remote Control Base w/ Flexible Stainless Steel Water Connectors w/ Ceramic Cartridge, Swivel Gooseneck & Vandal Resistant 2.2 GPM Aerator

Drawn

**DHL**

Checked

**KJG**

Approved

**JHB**

Scale:

**1:4**

Date:

**01/10/12**



# T&S BRASS AND BRONZE WORKS, INC.

2 Saddleback Cove / P.O. Box 1088  
Travelers Rest, SC 29690



REG. #A2601  
ISO #9001

Model No.  
**B-2387**

Item No.

Travelers Rest, SC: 800-476-4103 Simi Valley, CA: 800-423-0150 Fax: 864-834-3518 www.tsbrass.com

This Space for Architect/Engineer Approval

Job Name \_\_\_\_\_ Date \_\_\_\_\_

Model Specified \_\_\_\_\_ Quantity \_\_\_\_\_

Customer/Wholesaler \_\_\_\_\_

Contractor \_\_\_\_\_

Architect/Engineer \_\_\_\_\_

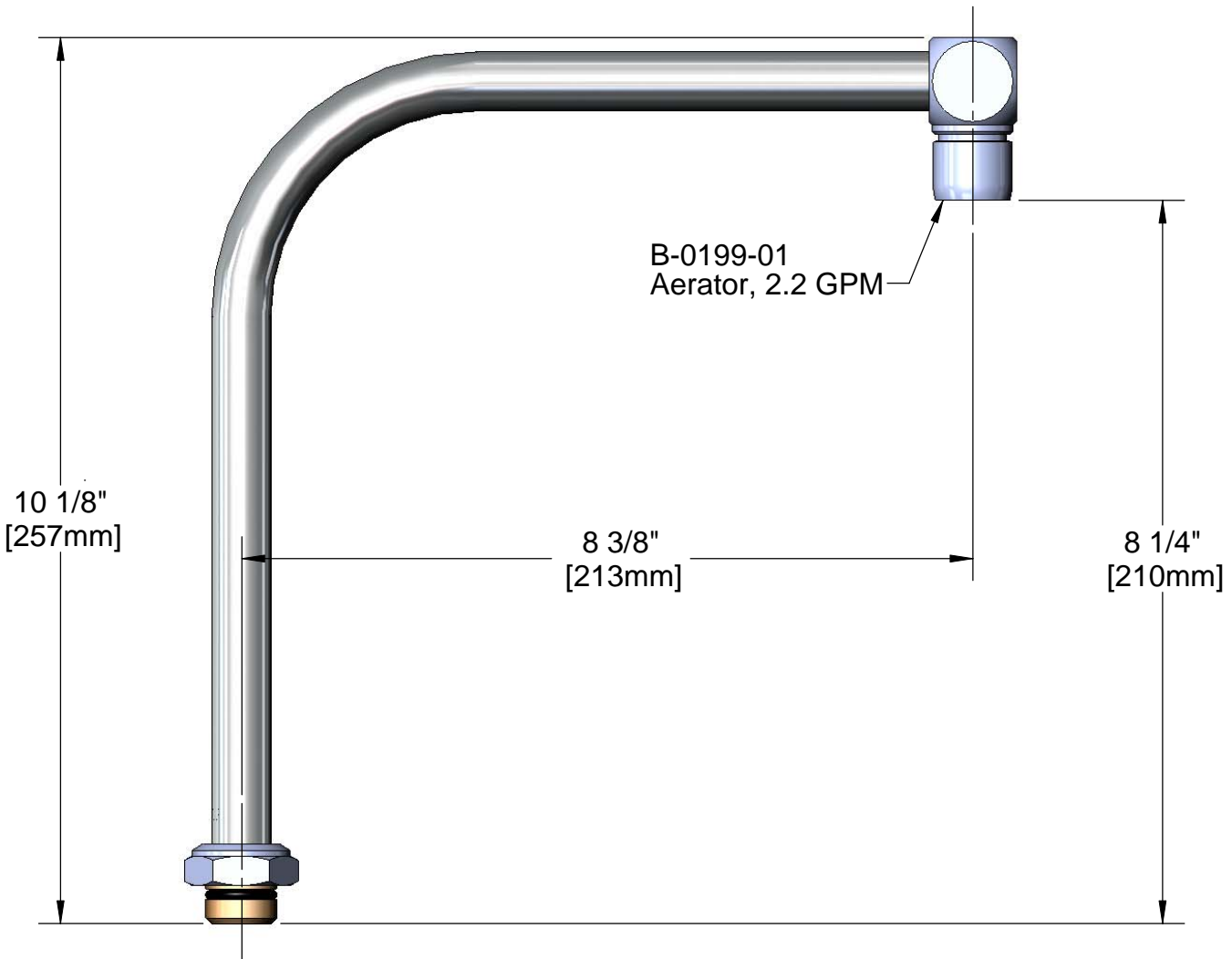

Product Specifications:  
**Swivel Gooseneck w/ 2.2 GPM Aerator**

Drawn <b>DMH</b>	Checked <b>JRM</b>	Approved <b>JHB</b>
Scale: <b>1:2</b>		Date: <b>12/11/09</b>