

STERLING®

A KOHLER COMPANY

SPRINGDALE®

Features

- Includes SilentShield® sound-absorption technology
- Spacious 7" (17.8 cm) deep basin
- Single compartment
- Satin finish
- Undermount rimless design
- Wide undermount lip
- Drawn from 19 gauge - type 304 (18-8) series nickel bearing stainless steel
- Installation hardware included for each type of installation
- 14-1/4" (36.2 cm) x 11-3/4" (29.8 cm) x 7" (17.8 cm)

Codes/Standards Applicable

Specified model meets or exceeds the following:

- ASME A112.19.3/CSA B45.4

SINGLE BASIN ENTERTAINMENT SINK

UCL1515
ALSO UCL1515B

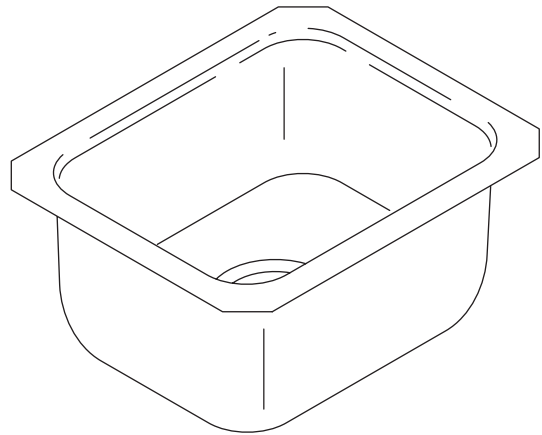

Colors/Finishes

- NA: None applicable

Specified Model

Model	Description	Holes	Large Basin Depth	Colors/Finishes
UCL1515	Single compartment sink	0	7" (17.8 cm)	<input type="checkbox"/> NA
UCL1515B	Single compartment sink with strainer	0	7" (17.8 cm)	<input type="checkbox"/> NA

SPRINGDALE®

Technical Information

Fixture:*	
Sink	
Basin area	12" (30.5 cm) x 9-1/2" (24.1 cm)
Water depth	7" (17.8 cm)
Drain hole	3-5/8" (9.2 cm) D.
* Approximate measurements for comparison only.	

Included components:	
Cut-out template	1030069-7
Strainer (for UCL1515-B only)	7400

Installation Notes

Install this product according to the installation guide.

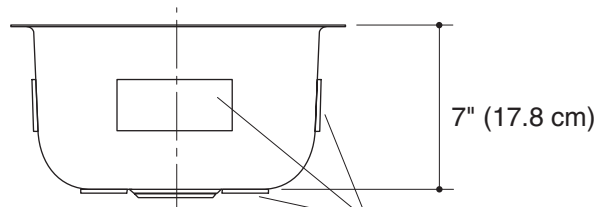
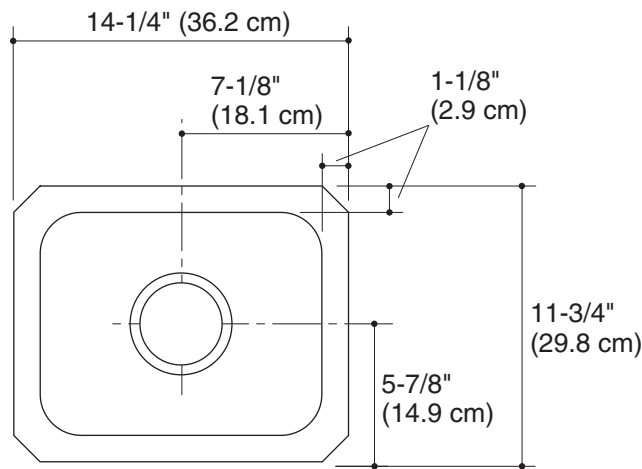

SilentShield™ Sound Pads

Mounting bracket assembly provides a secure installation.

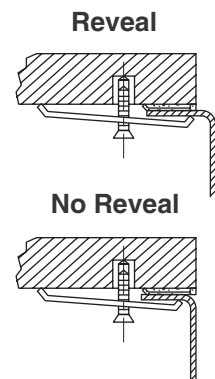

Product Diagram