

SPEAKMAN®

SM-3030

Sentinel Mark II® Pressure Balance Shower/Tub System

SPECIFICATION



FEATURES:

- Sentinel Mark II® concealed anti-scald balanced pressure shower
- Chrome plated brass wall plate with metal index.
- Chrome plated brass lever handle.
- Independent center sleeve allows up to 1 in. of rough-in variation.
- Adjustable temperature limit stop. Brass body.
- Pressure balancing & ceramic temperature regulating cartridge with built-in check valves.
- Can be installed back-to-back. Roughing-in template.
- Vandal-resistant standard.
- S-2272-E2 showerhead with flow control device reduces flow to 2.0 gpm (7.57 L/min) maximum.
- S-2500 shower arm and wall flange.
- S-1556 diverter tub spout.
- Four port valve with ½ in. female copper sweat inlets and shower outlet (tub outlet ½ NPT female).

COMPLIANCE:

- ASSE 1016 certified
- ASME 112.18.1/CSA B125.1 certified



FINISH:

- Polished Chrome (standard)

OPTIONS:

ADD SUFFIX TO MODEL #

- Integral stops -IS
- Less showerhead -LH
- S-2251 showerhead -1
- S-2252 showerhead -2
- S-2253 showerhead -3
- S-2292 showerhead -9
- Contractor Packs Available

WARRANTY:

- 1 year limited

SEE REVERSE FOR ROUGH-IN DIMENSIONS

THIS SPACE FOR ARCHITECT/ENGINEER APPROVAL.

SPEAKMAN®

400 ANCHOR MILL ROAD | NEW CASTLE, DE 19720
P: 800-537-2107 | F: 800-977-2747
WWW.SPEAKMANCOMPANY.COM

REVISION DATE: OCTOBER 2014



Management Systems
Registered to ISO 9001

271

SPEAKMAN®

Sentinel Mark II® Pressure Balance Shower/Tub System SM-3030

SPECIFICATION

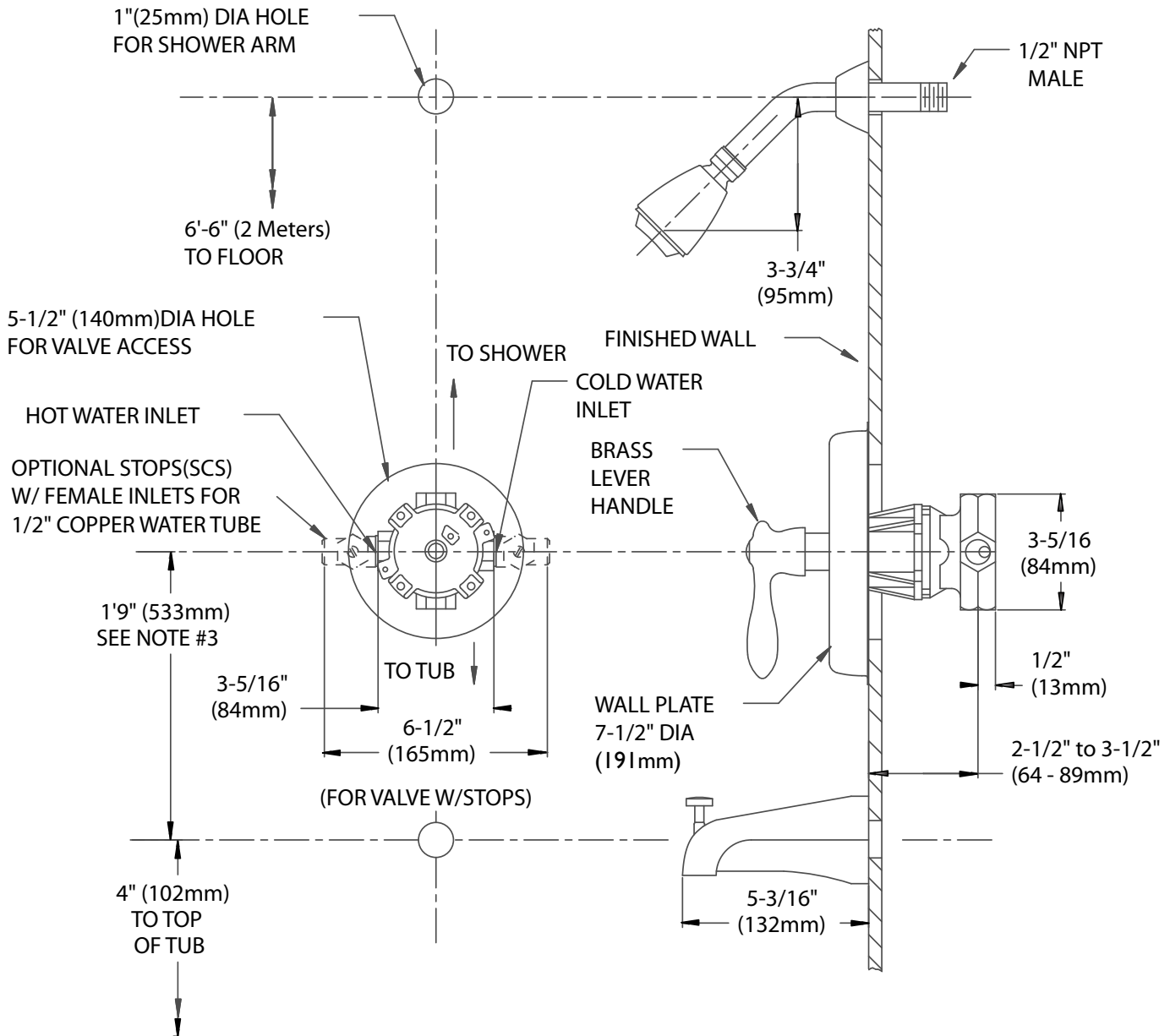

NOTE: 1. All dimensions are in inches (millimeters) unless otherwise specified and are subject to change without notice. 2. Unless otherwise specified all inlets and outlets are 1/2" female copper sweat. 3. For ADA mounting locations consult ADAAG, ANSI A117.1, or state regulations.

THIS SPACE FOR ARCHITECT/ENGINEER APPROVAL.

SPEAKMAN®

400 ANCHOR MILL ROAD | NEW CASTLE, DE 19720
 P: 800-537-2107 | F: 800-977-2747
 WWW.SPEAKMANCOMPANY.COM



Management Systems
 Registered to ISO 9001

REVISION DATE: OCTOBER 2014