

SPEAKMAN®

Combination Shower & Eyewash SE-693-ADA

SPECIFICATION

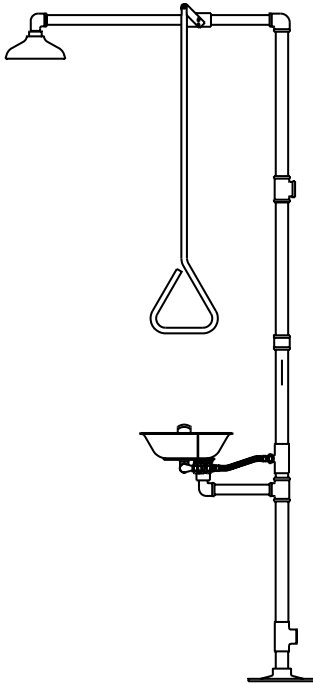

FEATURES:

- 8" Cicolac® yellow plastic showerhead
- Internal 20 gpm restrictor flow control
- 1" NPT female brass, chrome plated, full flow stay-open ball valve
- Extended powder coated yellow aluminum triangular pull rod activator
- 1 1/4" galvanized steel piping stanchion with brass fittings
- 1 1/4" NPT female inlet & waste
- 20 gpm @ 20 psi

EYE/FACE WASH: SE-582

- Stainless steel bowl
- (2) aerated yellow plastic spray outlets with flip-top dust caps
- 1/2" NPT female brass, chrome plated, full flow stay-open ball valve
- Stainless steel push handle activator
- 1/2" NPT female inlet
- 3.0 gpm @ 30 psi
- Universal Emergency Sign Included

COMPLIANCE:

- ANSI Z358.1

AVAILABLE FINISHES:

- Powder coated green (standard)

OPTIONS:

ADD SUFFIX TO MODEL #

- | | |
|--------------------------------|---------------------------------|
| • 30 GPM REGULATOR | <input type="checkbox"/> -30GPM |
| • FLOW SWITCH | <input type="checkbox"/> -FLW |
| • ANTI-FREEZE PROTECTION VALVE | <input type="checkbox"/> -FPV |
| • HAND-HELD SPRAY | <input type="checkbox"/> -HS |
| • ANTI-SCALD PROTECTION VALVE | <input type="checkbox"/> -SPV |
| • STAINLESS STEEL PULL ROD | <input type="checkbox"/> -SPR |
| • STAINLESS STEEL BALL VALVES | <input type="checkbox"/> -SSBV |
| • STAINLESS STEEL SHOWERHEAD | <input type="checkbox"/> -SSH |

WARRANTY:

- 1 year limited

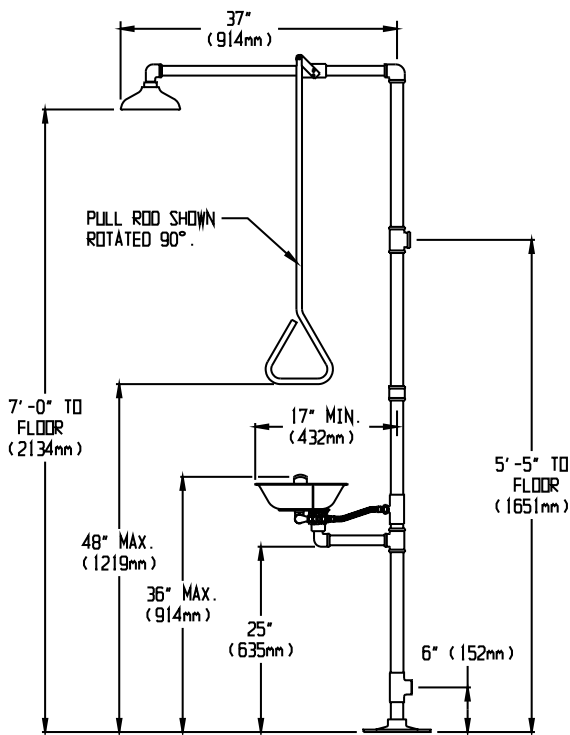

NOTE: 1. All dimensions are in inches (millimeters) unless otherwise specified and are subject to change without notice.

THIS SPACE FOR ARCHITECT/ENGINEER APPROVAL.

SPEAKMAN®

400 ANCHOR MILL ROAD | NEW CASTLE, DE 19720
P: 800-537-2107 | F: 800-977-2747
WWW.SPEAKMANCOMPANY.COM



REVISION DATE: FEB. 2012