



EW-43000

SERIES

► **Description**

Triple Station Solid Surface Lavatory System Equipped with Sloan OPTIMA® Electronic Sensor Technology.

► **Model**

EW-43000 Three Station SloanStone Lavatory System with Integrated Sloan Optima® Electronic Sensor Technology

► **Specifications**

Triple Station Lavatory System with Sloan Electronic Sensor Technology with the following features:

- Lavatory constructed of Non-porous SloanStone Solid Surface Material
- Lavatory supported by a heavy duty, 14 gauge, Type 304 stainless steel, satin finish Pedestal with 14 gauge galvanized steel Mounting Plate
- Single continuous basin with user Comfort Curve Design
- Front access panels for easy maintenance access
- 1½" stainless steel drains with Rapid Siphonic Action
- Integral Dual Drainage System
- Sloan Optima Electronic Sensor Technology for hands free operation
- Lavatory System is shipped pre-plumbed with Sloan Electronic Controls for easy installation

Sloan Optima® Electronics feature:

- Sloan Optima Sensor Technology for reliable performance
- Troubleshooting LED Indicator Lights
- Filtered Solenoid with serviceable Strainer Filter
- Stainless Steel vandal resistant Spouts
- Water saving 0.5 gpm/1.9 Lpm max. Aerator
- Hardwire powered
- Below Deck Thermostatic Mixing Valve

► **Variations**

- JVC** Juvenile Height Cabinet
- SD** Soap Dispenser
- FM** Floor Mounted

► **Colors**

- AH** Ash
- SS** Sand
- SL** Slate
- TP** Taupe
- PL** Pearl
- JT** Jet
- JD** Jade
- AM** Amber
- IN** Indigo

► **Warranty**

3 year (limited)



**The New SloanStone™ Lavatory System
 — The Perfect Match**

The performance and dependability of Sloan Optima® and the durability of Solid Surface are now combined in the SloanStone™ Lavatory System.

Hygienic and durable, SloanStone™ is stain, chemical and impact resistant. A rugged stainless steel support structure ensures long lasting strength. A SloanStone™ Lavatory System is easy to install and easy to maintain.

The “hands-free” operation of a SloanStone™ Optima® Electronic Lavatory System ensures hygiene while maintaining an aesthetically pleasing look that is suited for any public rest room installation.



The lavatory system is designed to comply with all applicable ADA, UFAS, Texas Accessibility Standards (TAS), and ANSI Z124.3 and Z124.6 accessibility guidelines when mounted at the standard 34" rim height.

Sloan Optima Electronics are:



This space for Architect/Engineer approval	
Job Name _____	Date _____
Model Specified _____	Quantity _____
Variations Specified _____	
Customer/Wholesaler _____	
Contractor _____	
Architect _____	

The information contained in this document is subject to change without notice.

EW-43000

SERIES

Triple Station Lavatory System

OPERATION

As the user's hands enter the beam's effective range, the beam is reflected back into the sensor receiver and activates the solenoid valve allowing water to flow from the spout. Water will flow until user's hands are removed or until the time out limit is reached.

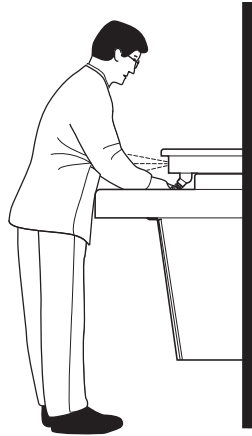

SLOANSTONE™ COLORS

Standard Colors

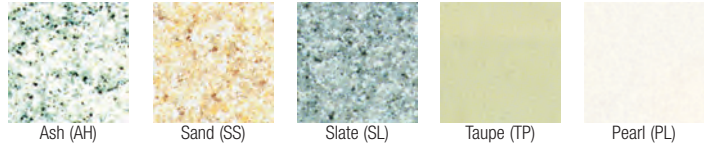

Special Colors

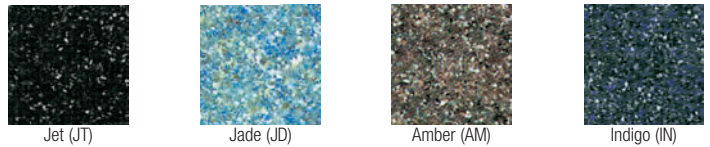

ROUGH-IN

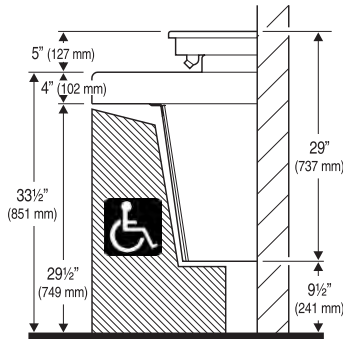
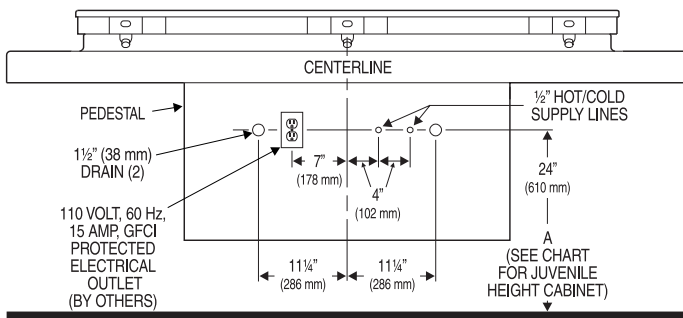
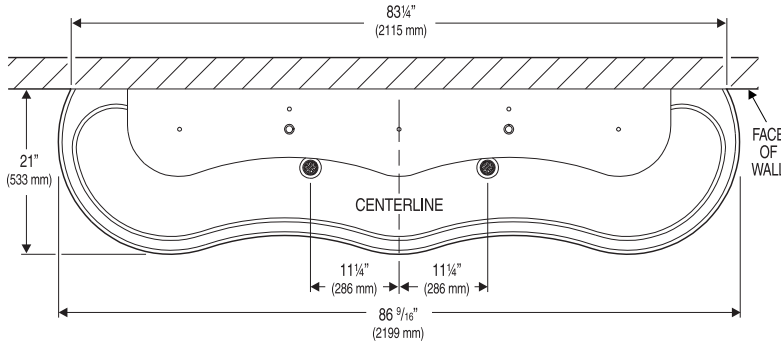

Standard Height Cabinet

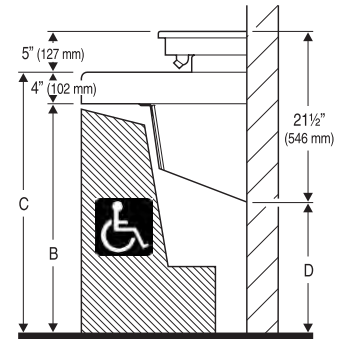

Juvenile Height Cabinet

Consult local electrical codes for the mounting location of the 110/24 VAC Class 2 transformer.

For additional technical information, contact the Sloan Installation Engineering Department at 1-888-SLOAN-14 (1-888-756-2614) or techsupport@sloanvalve.com

VARIABLE MOUNTING HEIGHT CHART

 DIMENSION DESCRIPTION	T.A.S. AGES 4-10	T.A.S. AGES 11-15	A.D.A. STANDARD
A ROUGH-IN	20 1/2" (521 mm)	22 1/2" (572 mm)	24" (610 mm)
B KNEE CLEARANCE	26" (660 mm)	28" (711 mm)	29 1/2" (749 mm)
C RIM HEIGHT	30" (762 mm)	32" (813 mm)	33 1/2" (851 mm)
D TOE CLEARANCE	13 1/2" (343 mm)	15 1/2" (394 mm)	17" (432 mm)

SLOAN VALVE COMPANY • 10500 SEYMOUR AVENUE • FRANKLIN PARK, IL 60131

Phone: 1-800-9-VALVE-9 or 1-847-671-4300 • Fax: 1-800-447-8329 or 1-847-671-4380 • <http://www.sloanvalve.com>