

Sloan® Model Flushometer

186-0.5

► **Description**

Exposed Urinal Flushometer for 3/4" top spud urinals.

► **Flush Cycle**

□ Model 186-0.5 High Efficiency (0.5 gpf/1.9 Lpf)

► **Variations**

□ **DFB** Dual Filtered Fixed Bypass Diaphragm

► **Specifications**

Quiet, Exposed, Diaphragm Type, Chrome Plated Urinal Flushometer with the following features:

- High Chloramine Resistant PERMEX™ Synthetic Rubber Diaphragm with Linear Filtered Bypass and Vortex Cleansing Action™
- ADA Compliant Metal Oscillating Non-Hold-Open Handle with Triple Seal Handle Packing
- 3/4" I.P.S. Screwdriver Bak-Chek™ Angle Stop
- Vandal Resistant Stop Cap
- Adjustable Tailpiece
- Vacuum Breaker with Flush Connection
- Spud Coupling and Spud Flange for 3/4" Top Spud
- Sweat Solder Adapter with Cover Tube and Cast Wall Flange
- High Copper, Low Zinc Brass Castings for Dezincification Resistance
- Non-Hold-Open Handle and No External Volume Adjustment to Ensure Water Conservation
- Low Consumption flush accuracy
- Handle Packing, Stop Seat and Vacuum Breaker Molded from PERMEX™ Rubber Compound for Chloramine Resistance

Valve Body, Cover, Tailpiece and Control Stop shall be in conformance with ASTM Alloy Classification for Semi-Red Brass. Valve shall be in compliance to the applicable sections of ASSE 1037.

► **Accessories**

See Accessories Section of the Sloan catalog for details on these and other Flushometer variations.

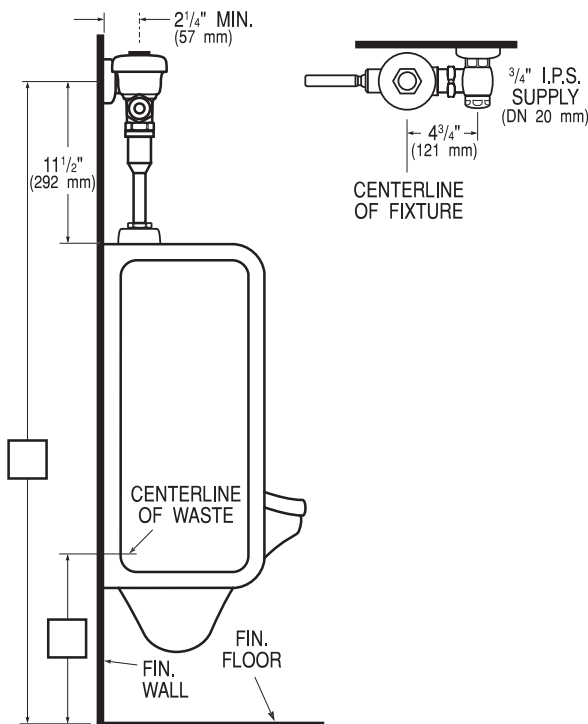

Sloan 186-0.5 S.S. — Rev. 0 (06/10)
Copyright © 2010 SLOAN VALVE COMPANY



This space for Architect/Engineer approval

The information contained in this document is subject to change without notice.



SLOAN VALVE COMPANY • 10500 SEYMOUR AVE. • FRANKLIN PARK, IL 60131
Ph: 1-800-9-VALVE-9 or 1-847-671-4300 • Fax: 1-800-447-8329 or 1-847-671-4380
www.sloanvalve.com