



186 HW

► **Description**
Exposed, Hardwired, Sensor Activated, Royal® Optima® SMOOTH® Urinal Flushometer for ¾" top spud urinals.

- **Flush Cycle**
- Model 186-0.125 HW High Efficiency (0.125 gpf/0.5 Lpf)
 - Model 186-0.25 HW High Efficiency (0.25 gpf/0.9 Lpf)
 - Model 186-0.5 HW High Efficiency (0.5 gpf/1.9 Lpf)

► **Specifications**
Quiet, Exposed, Diaphragm Type, Chrome Plated Urinal Flushometer with the following features:

Flushometer

- For Flushing Volumes 0.125 and 0.25: Dual Linear Filtered Bypass Diaphragm
- For Flushing Volumes 0.5: Dual Filtered Bypass Diaphragm
- ADA Compliant Metal Oscillating Non-Hold-Open Handle with Triple Seal Handle Packing
- ¾" I.P.S. Screwdriver Bak-Chek® Angle Stop
- Free Spinning Vandal Resistant Stop Cap
- Adjustable Tailpiece
- High Back Pressure Vacuum Breaker Flush Connection with One-piece Bottom Hex Coupling Nut
- Spud Coupling and Flange for ¾" Top Spud
- Sweat Solder Adapter w/Cover Tube and Cast Wall Flange w/Set Screw
- High Copper, Low Zinc Brass Castings for Dezincification Resistance
- Non-Hold-Open Handle, Fixed Metering Bypass and No External Volume Adjustment to Ensure Water Conservation
- Flush Accuracy Controlled by CID™ Technology
- Diaphragm, Handle Packing, Stop Seat and Vacuum Breaker molded from PERMEX® Rubber Compound for Chloramine Resistance

Optima SMOOTH Unit

- ADA Compliant OPTIMA® SMOOTH® Line Powered Infrared Sensor for automatic "Hands-free" operation
- Sensor with Automatic Range Adjustment
- Chrome Plated Metal Sensor Housing
- Mechanical Manual Override Flush Handle
- "User in View" Flashing LED
- 25 to 80 psi Operating Range

Valve Body, Cover, Tailpiece and Control Stop shall be in conformance with ASTM Alloy Classification for Semi-Red Brass. Valve shall be in compliance to the applicable sections of ASSE 1037.

► **Accessories**

• **Transformers**

- EL-386** Plug-In Adaptor (120 VAC/6 VAC, 3 VA) – will operate 1 unit
- EL-451** Box Mount Transformer (120 VAC/6 VAC, 25 VA) – will operate up to 8 units

See Accessories Section of the Sloan catalog for details on these and other Royal® Optima® Flushometer Accessories.

► **Fixtures**

Consult Sloan for Sloan brand matching fixture options.



► **ADA Compliant**

► **Automatic**

Sloan SMOOTH® equipped Flushometers provide the ultimate in sanitary protection and automatic operation. The Flushometer operates by means of a hardwired infrared sensor. Once the user enters the sensor's effective range and then steps away, the SMOOTH™ Unit initiates the flushing cycle to flush the fixture. State-of-the-art Technology enables activation of a manual override without "double flushing" occurring as the user departs (locks out sensor for approximately 10 seconds).

► **Hygienic**

The Royal® Optima® SMOOTH® Flushometer is the next advancement in hygiene. It uses sensor technology to transform manual installations into electronic, hands-free operation. User makes no physical contact with the Flushometer surface except to initiate the Override Handle when required. Helps control the spread of infectious diseases.

► **Economical**

Automatic operation provides water usage savings over other flushing devices. Reduces maintenance and operation costs. Installation does not require turning off water to the valve.

► **Warranty**

3 year (limited)

This space for Architect/Engineer approval	
Job Name _____	Date _____
Model Specified _____	Quantity _____
Variations Specified _____	
Customer/Wholesaler _____	
Contractor _____	
Architect _____	

186 HW

Description

Exposed, Hardwired, Sensor Activated, Royal® Optima® SMOOTH® Urinal Flushometer for ¾" top spud urinals.

Flush Cycle

- Model 186-0.125 HW High Efficiency (0.125 gpf/0.5 Lpf)
- Model 186-0.25 HW High Efficiency (0.25 gpf/0.9 Lpf)
- Model 186-0.5 HW High Efficiency (0.5 gpf/1.9 Lpf)

ELECTRICAL SPECIFICATIONS

Control Circuit

6 VDC Input

OPTIMA® Sensor Type

Active Infrared with Automatic Adjustment

OPTIMA® Sensor Range

Normal Range:

26" - 32" (660 mm-813 mm)

Reduced Range:

20" - 26" (508 mm-660 mm)

Indicator Lights

User in View

Operating Pressure

25-80 psi (172-552 kPa)

Transformer

Sloan Part #EL-386 (Plug-in)
120 VAC, 50/60 Hz, Primary
6 VAC, 50/60 Hz, Secondary
Class II, 3 VA.

Sloan Part #EL-451 (Box Mount)

120 VAC, 50/60 Hz, Primary
6 VAC, 50/60 Hz, Secondary
Class II, 25 VA.

OPERATION

1. A continuous, invisible light beam is emitted from the SMOOTH™ unit's Infrared Sensor.

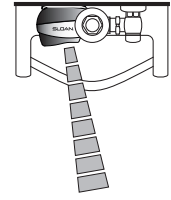

2. When the user enters the sensor's effective range, the Red LED light in the sensor window flashes for eight seconds. After eight seconds of sensing the user, the light will stop flashing and the unit waits for the user to step away before initiating a flush cycle.

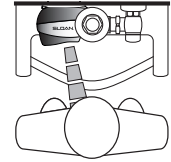

3. When the user steps away, the unit initiates a flush cycle. The unit then automatically resets and is ready for the next user.

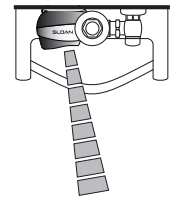

DIMENSIONS

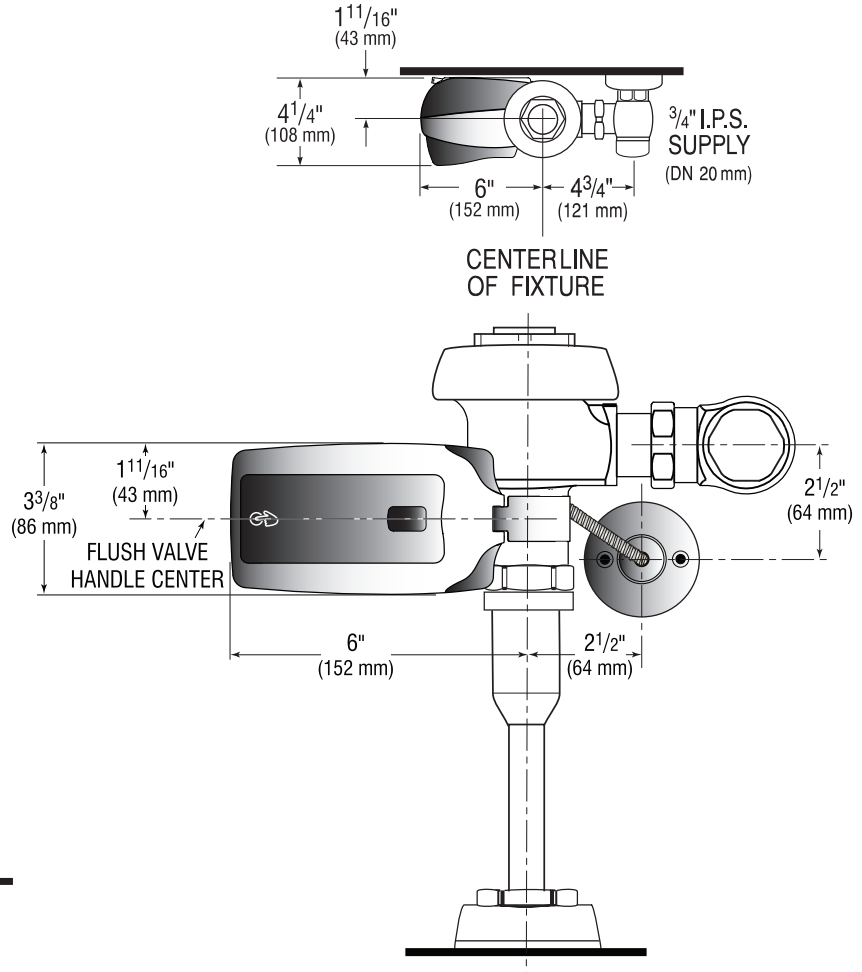
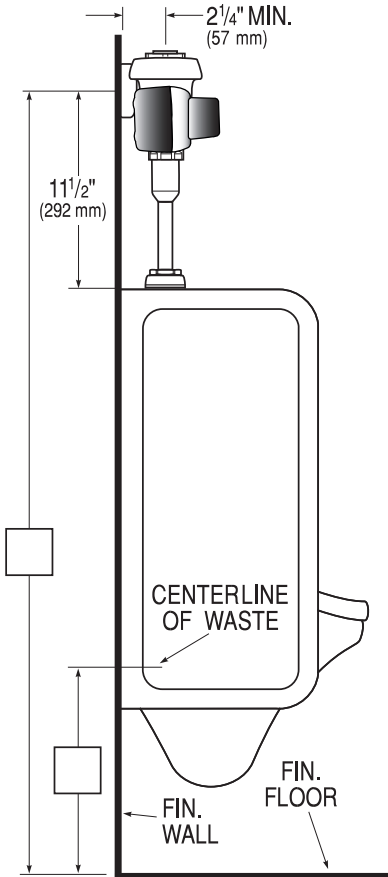

SLOAN VALVE COMPANY • 10500 SEYMOUR AVENUE • FRANKLIN PARK, IL 60131

Phone: 1-800-9-VALVE-9 or 1-847-671-4300 • Fax: 1-800-447-8329 or 1-847-671-4380 • www.sloanvalve.com