

PLATINUM® • CONDENSING GAS WATER HEATER STAINLESS STEEL TANK

TANK SERIES 70 GALLONS

MODEL NUMBER ▶	199 SS A-PN	299 SS A-PN	399 SS A-PN
Input Btu/h	199,000	299,000	399,000
GPH Recovery Rate at 40°F to 140°F	221	340	444
Storage Capacity - gallons	80	70	70
1st Hour Delivery (100°F ΔT) - gallons	289	397	501
Hot Outlet and Cold Inlet - NPT	2	2	2
Flue Connection Diameter - inches	3 *	4	4
Approximate Shipping Weight - lbs	1000	1100	1100

Dimensions are in inches unless otherwise noted.

For standard and optional equipment, see form # PV 6811.

* When connected with field provided 3" x 4" adapter of the same material as required for venting (see I&M).

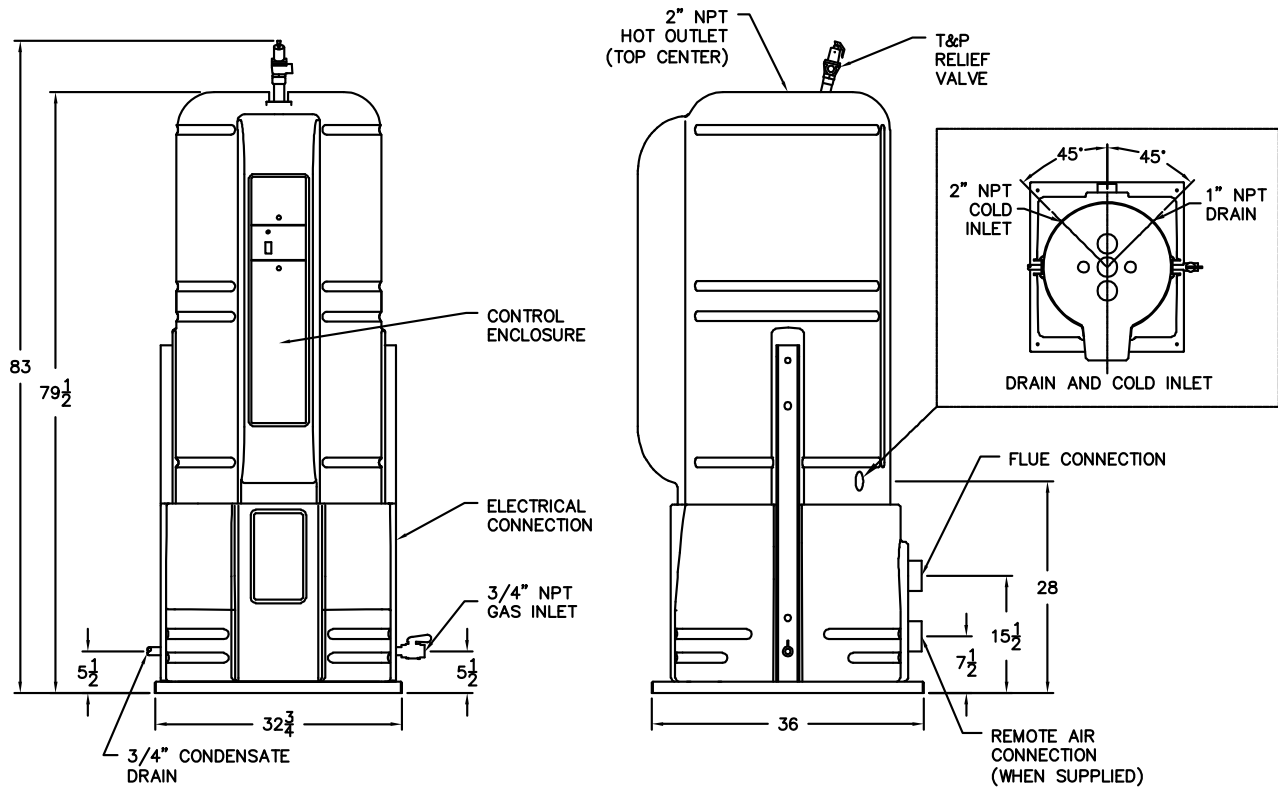

STANDARD GAS PRESSURE REQUIREMENTS

MINIMUM FLOW GAS PRESSURE: 4.5" W.C.
MAXIMUM STATIC GAS PRESSURE: 10.5" W.C.
FOR GAS PRESSURES OUTSIDE OF THIS RANGE,
CONTACT YOUR PVI REPRESENTATIVE.

STANDARD ELECTRICAL REQUIREMENTS

120V, 1Ø, 60 HZ.
MAXIMUM AMP DRAW (TRIAL FOR IGNITION): 6
CONTINUOUS AMP DRAW WHEN FIRING: 1.3
CONTINUOUS AMP DRAW DURING STANDBY: 0.03

VENTING REQUIREMENTS

CATEGORY IV - POSITIVE PRESSURE, CONDENSING.
UL CLASSIFIED FOR SCHEDULE 40, SOLID-WALL PVC
OR CPVC PIPE.
"SANI" TEMPERATURE HEATER REQUIRES CPVC VENT PIPE

SEE INSTALLATION MANUAL FOR VENTING
AND DIRECT COMBUSTION AIR GUIDELINES.



PVI RESERVES THE RIGHT TO CHANGE THE DESIGN
AND SPECIFICATION WITHOUT NOTICE.