

BUILDER SERIES

Oasis



"IF" Model Tile Flange & Partial Apron



"S" Model w/ Full Apron & Removable Access Panel

60-INCH WIDE MODELS

Futura 4260 (Tile Flange)

Rough-In Dimensions OV-S-310 / OVG-S-310 60" wide x 43-1/4" deep x 22" high
 OV-IF-310 / OVG-IF-310

Finished Dimensions OV-S-310 / OVG-S-310 60" wide x 42" deep x 20-3/4" high
 OV-IF-310 / OVG-IF-310

Unit Features

- Vacuum Formed Acrylic or Gelcoat Surface
- 2" Dia. RH or LH Drain (see reverse side for location)
- 2-1/2" Dia. Overflow (see reverse side for location)
- Twin, Contoured Armrests
- "S" Model: Integral Tile Flange & Full Apron
- "IF" Model: Integral Tile Flange & Partial Apron
- Pre-Leveled Block Base System
- Balsa Wood Core Floor Structure
- Textured Floor Pattern

Special Notes

- Whirlpool System Available (see reverse side for details)
- Air System Available (see reverse side for details)
- UL Listed Whirlpool & Air Systems
- Removable Access Panel Included on "S" Model w. System
- Model Available In Self-Rimming Design

Unit / System Order Number

Acrylic: OV-S-310 R or L Drain / 0ND (soaking tub)
 OV-S-310 R or L Drain / 6P (Builder System)
 OV-S-310 R or L Drain / CWS (Carress System)
 OV-S-310 R or L Drain / AR2 (Revive Air System)

 OV-IF-310 R or L Drain / 0ND (soaking tub)
 OV-IF-310 R or L Drain / 6P (Builder System)
 OV-IF-310 R or L Drain / CWS (Carress System)
 OV-IF-310 R or L Drain / AR2 (Revive Air System)

Unit / System Order Number

Gelcoat: OVG-S-310 R or L Drain / 0ND (soaking tub)
 OVG-S-310 R or L Drain / 6P (Builder System)
 OVG-S-310 R or L Drain / CWS (Carress System)

 OVG-IF-310 R or L Drain / 0ND (soaking tub)
 OVG-IF-310 R or L Drain / 6P (Builder System)
 OVG-IF-310 R or L Drain / CWS (Carress System)

System Trim

Standard 6P & CWS Trim (order code): White trim on White unit (WHT) - Bone trim on Bone unit (BON) - Biscuit trim on Biscuit unit (BSC)

Order Number / Description

CWS: *Carress System* includes: 4-Adjustable side jets, 2-rotating foot jets, 2-micro pulse back jets, variable flow control, twin air controls, electronic system control, 13.5 amp pump/motor, and a removable access panel (S model).

Options: In-Line Heater (1*) (order: ILH)
 Ozone Generator (1*) (order: OZG)
 Chromatherapy Pkg (1*, 2*) (order: CLT)
 Water Level Sensor (1*, 2*) (order: LWV)
 Trim Upgrade (1*)
 Chrome (order: CWS-CHR)
 Brushed (Satin) Nickel (order: CWS-SNK)

Order Number / Description

6P: *Builder System* includes: 6-Adjustable jets, twin air controls, pneumatic system control, 5.50 amp pump/motor, and a removable access panel (S model).

Options: In-Line Heater (1*) (order: ILH)
 Ozone Generator (1*) (order: OZG)

AR2: *Revive Air System* (3*) includes: (47) Perimeter air ports, electronic system control, 12.0 amp, 600-watt blower with ceramic heater, and a removable access panel (S model).

Notes: (1*) Factory installed options
 (2*) Includes system control upgrade
 (3*) Available on acrylic models only

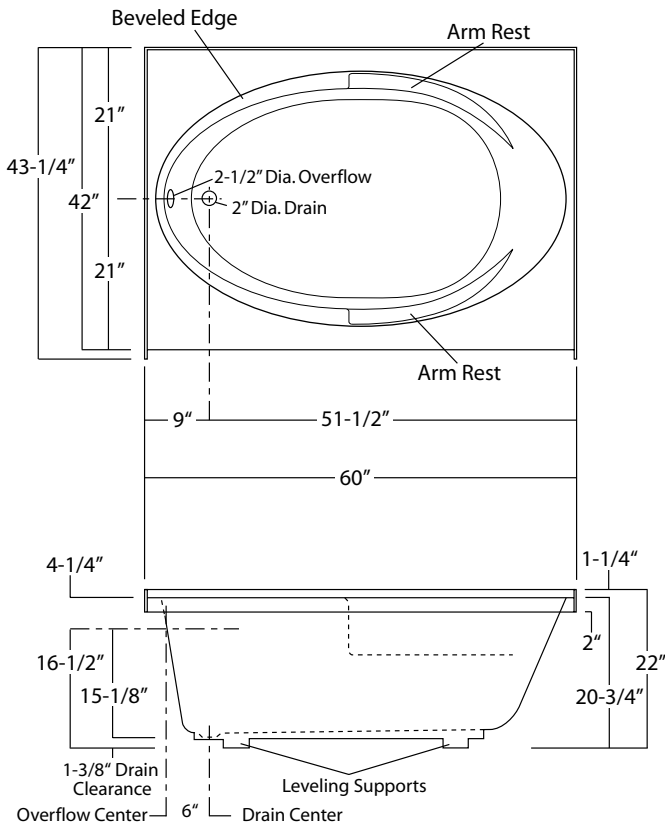

Futura 4260: OV-IF-310L / OVG-IF-310L (illustrated)
 (S model full apron extends down to room floor)
 Sump Dimen: 47" long x 30-1/2" wide x 18" deep
 Sump Capacity: 62 gal. (unoccupied - to overflow)
 Whirlpool Operating: 32 gal.

Carress System

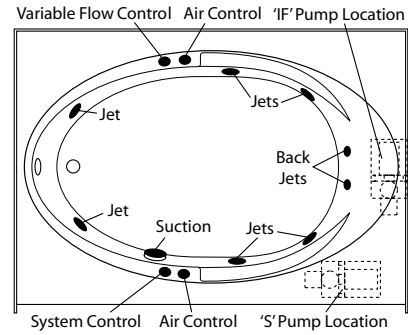

Builder System

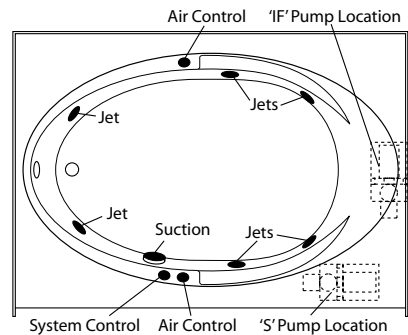

Revive Aire System

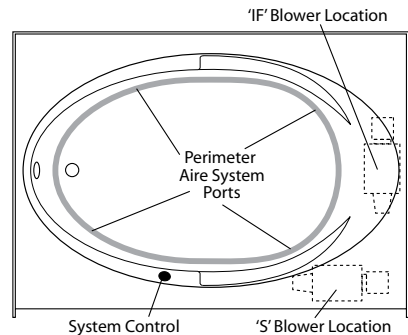

Photographic images may include optional components and appear different than actual product.
 Dimensions shown are maximum. Due to the nature of the materials involved, actual unit dimensions can vary (tolerances: +0 / -3/8 inch).
 Oasis reserves the right to modify or discontinue product and/or associated equipment without prior written or verbal notification or obligation.