

BUILDER SERIES



59-3/4-INCH WIDE MODEL

Classic 4060 (Self-Rimming)

Unit Dimensions

59-3/4" wide x 40" deep x 20-3/4" high

Unit Features

- Vacuum Formed Acrylic
- 2" Dia. End Drain (see reverse side for location)
- 2-1/2" Dia. Overflow (see reverse side for location)
- Pre-Leveled Block Base System
- Balsa Wood Core Floor Structure
- Textured Floor Pattern

Special Notes

- Whirlpool System Available (see reverse side for details)
- Air System Available (see reverse side for details)
- UL Listed Whirlpool & Air Systems

Unit / System Order Number

Acrylic: OV-B-340 / 0ND (soaking tub)
OV-B-340 / 6P (Builder System)
OV-B-340 / CWS (Carress System)
OV-B-340 / AR2 (Revive Air System)

System Trim

Standard 6P & CWS Trim (order code): White trim on White unit (WHT) - Bone trim on Bone unit (BON) - Biscuit trim on Biscuit unit (BSC)

Order Number / Description

CWS: *Carress System* includes: 4-Adjustable side jets, 2-micro pulse back jets, variable flow control, twin air controls, electronic system control, and 13.5 amp pump/motor.

Options: In-Line Heater (1*) (order: ILH)
 Ozone Generator (1*) (order: OZG)
 Chromatherapy Pkg (1*, 2*) (order: CLT)
 Water Level Sensor (1*, 2*) (order: LWV)
 Trim Upgrade (1*)
 Chrome (order: CWS-CHR)
 Brushed (Satin) Nickel (order: CWS-SNK)

Order Number / Description

6P: *Builder System* includes: 4-Adjustable jets, twin air controls, pneumatic system control, and 5.50 amp pump/motor.

Options: In-Line Heater (1*) (order: ILH)
 Ozone Generator (1*) (order: OZG)

AR2: *Revive Air System* (3*) includes: (44) Perimeter air ports, electronic system control, and a 12.0 amp, 600-watt blower with ceramic heater.

Notes: (1*) Factory installed options
 (2*) Includes system control upgrade
 (3*) Available on acrylic models only

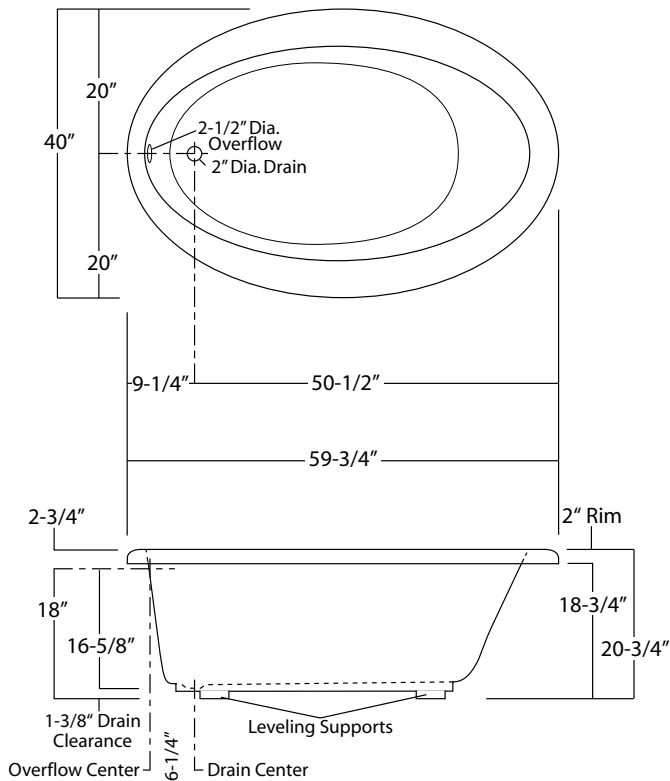

Sump Dimen: 47" long x 27" wide x 18-1/2" deep
 Sump Capacity: 62 gal. (unoccupied - to overflow)
 Whirlpool Operating: 40 gal.

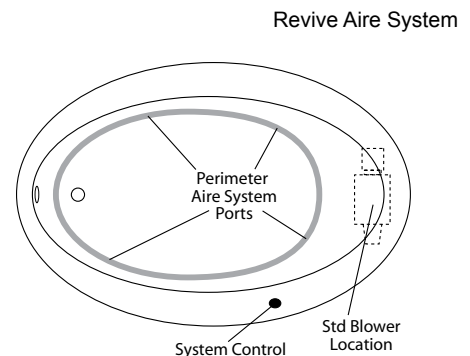
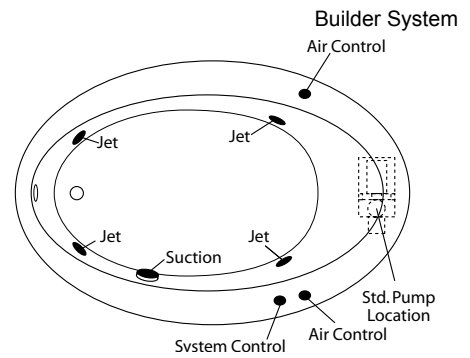
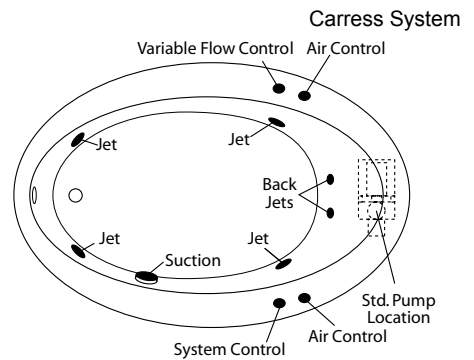

Photographic images may include optional components and appear different than actual product.
 Dimensions shown are maximum. Due to the nature of the materials involved, actual unit dimensions can vary (tolerances: +0 / -3/8 inch).
 Oasis reserves the right to modify or discontinue product and/or associated equipment without prior written or verbal notification or obligation.