

BUILDER SERIES

Oasis



60-INCH WIDE MODELS

BA-R-41 (Tile Flange)

BA-R-51 (Tile Flange)

Rough-In Dimensions	BA-R-41 BA-R-51	60" wide x 30-1/2" deep x 18-1/2" high (std model) 60" wide x 33-1/4" deep x 18-1/2" high (std model)
Finished Dimensions	BA-R-41 BA-R-51	60" wide x 29-1/4" deep x 17-1/4" high (std model) 60" wide x 32" deep x 17-1/4" high (std model)

Unit Features

- Gelcoat Surface
- 2" Dia. RH or LH Drain (see reverse side for location)
- 2-1/2" Dia. Overflow (see reverse side for location)
- Integral Unit Apron
- Balsa Wood Core Floor Structure
- Textured Floor Pattern

Special Notes

- ABF Model Provides Additional Drain Clearance
- Whirlpool System Available (see reverse side for details)
- UL Listed Whirlpool System

Unit / System Order Number

Gelcoat: BA-R-41R/L / 0ND (soaking tub)
BA-R-41R/L ABF / 0ND (soaking tub)

Unit / System Order Number

Gelcoat: BA-R-51R/L / 0ND (soaking tub)
BA-R-51R/L ABF / 0ND (soaking tub)
BA-R-51R/L / 6P (Builder System)
BA-R-51R/L ABF / 6P (Builder System)

System Trim

Standard 6P Trim (order code): White trim on White unit (WHT) - Bone trim on Bone unit (BON) - Biscuit trim on Biscuit unit (BSC)

Order Number / Description

6P: *Builder System* includes: 6-Adjustable jets, twin air controls, pneumatic system control, and 5.50 amp pump/motor.

Options: In-Line Heater (1*) (order: ILH)
 Ozone Generator (1*) (order: OZG)

Notes: (1*) Factory installed

Removable access panel currently not available for these models.

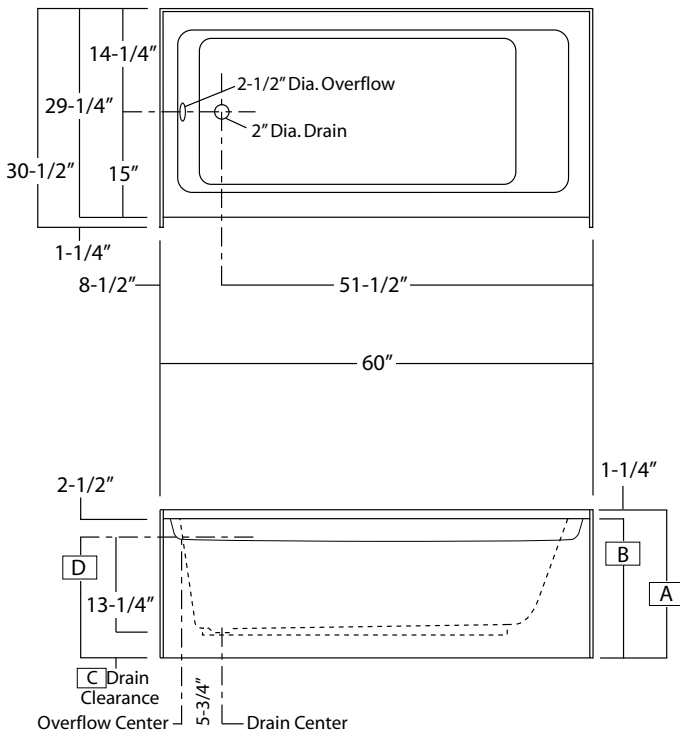

BA-R-41L ABF (illustrated)

Sump Dimen: 48" long x 21" wide x 15" deep
 Sump Capacity: 38 gal. (unoccupied - to overflow)
 Whirlpool Operating: NA

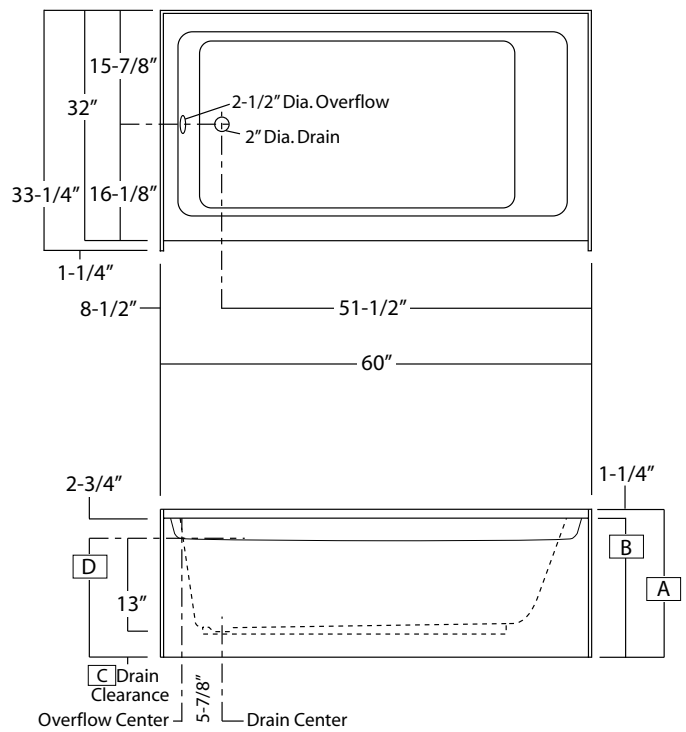

BA-R-51L ABF (illustrated)

Sump Dimen: 48" long x 24" wide x 15" deep
 Sump Capacity: 52 gal. (unoccupied - to overflow)
 Whirlpool Operating: 33 gal.

BA-R-41		
	Std Unit	ABF Unit
A	18-1/2"	20-1/2"
B	17-1/4"	19-1/4"
C	1-1/2"	3-1/2"
D	14-3/4"	16-3/4"

BA-R-51		
	Std Unit	ABF Unit
A	18-1/2"	20-1/2"
B	17-1/4"	19-1/4"
C	1-1/2"	3-1/2"
D	14-1/2"	16-1/2"

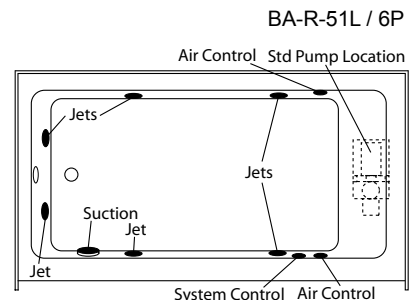

Photographic images may include optional components and appear different than actual product.
 Dimensions shown are maximum. Due to the nature of the materials involved, actual unit dimensions can vary (tolerances: +0 / -3/8 inch).
 Oasis reserves the right to modify or discontinue product and/or associated equipment without prior written or verbal notification or obligation.