

SPECIFICATIONS FOR
CUYAMA

NativeStone™ Collection

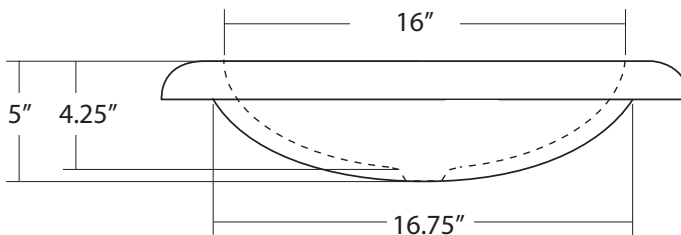
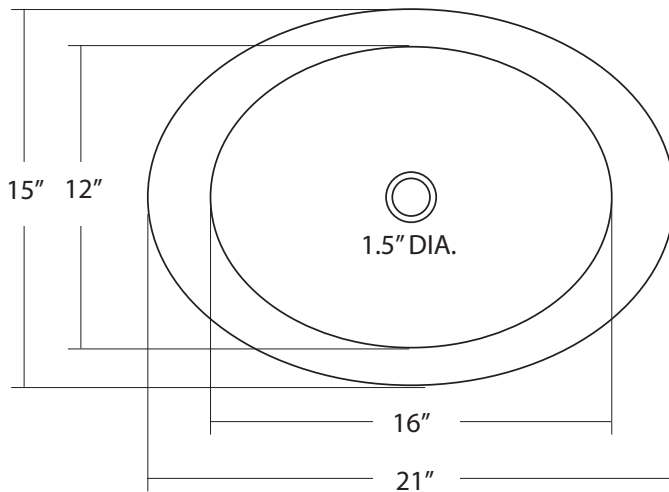

NSL2115-A Ash
NSL2115-S Slate
NSL2115-P Pearl

PRODUCT DETAILS

- * 21" x 15" x 5" OD
- * 16" x 12" x 4.25" ID
- * Dimensions are not exact and may vary $\pm 1/4"$
- * 1.5" drain opening
- * Sealed with impermeable nano sealer

INSTALLATION

- * Drop-in

COORDINATING PRODUCTS

- * Drains: DR120, DR150 or DR160

STANDARDS COMPLIANCE

- * UPC / cUPC

IMPORTANT

Due to the handcrafted nature of this product, it will vary in finish, texture, and other details. Dimensions may vary up to $1/4"$. We recommend waiting for the actual product before making any installation cuts.