

## FAUCET DESCRIPTION

- Solid brass construction with chrome finish
- 3/8" compression x 15" stainless steel supply lines

## OPERATION

- Lever style handle
- Temperature controlled by 110° arc of handle travel

## FLOW

- Aerator is limited to 2.2 gpm max (8.3 L/min)

## CARTRIDGE

- Ceramic disc cartridge with temperature limit stop
- Nonmetallic/nonferrous and ceramic material

## STANDARDS

- Third party certified to ASME A112.18.1/CSA B125.1, ICC A117.1, and all applicable requirements referenced therein
- Certified to ANSI/NSF 61/9
- Complies with California Proposition 65 and with the Federal Safe Drinking Water Act
- ADA  for lever handle

## WARRANTY

- Warranted for 5 years against materials or manufacturing defects

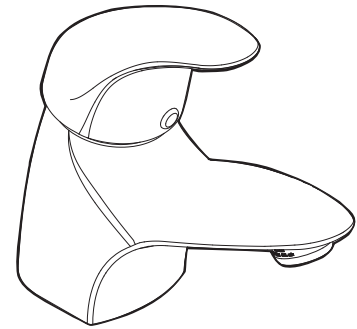

**Single-Handle Lavatory Faucet  
Model: 8417**

**NOTE:** DESIGNED TO BE INSTALLED THROUGH 1 HOLE 1-3/8" MIN. DIA.

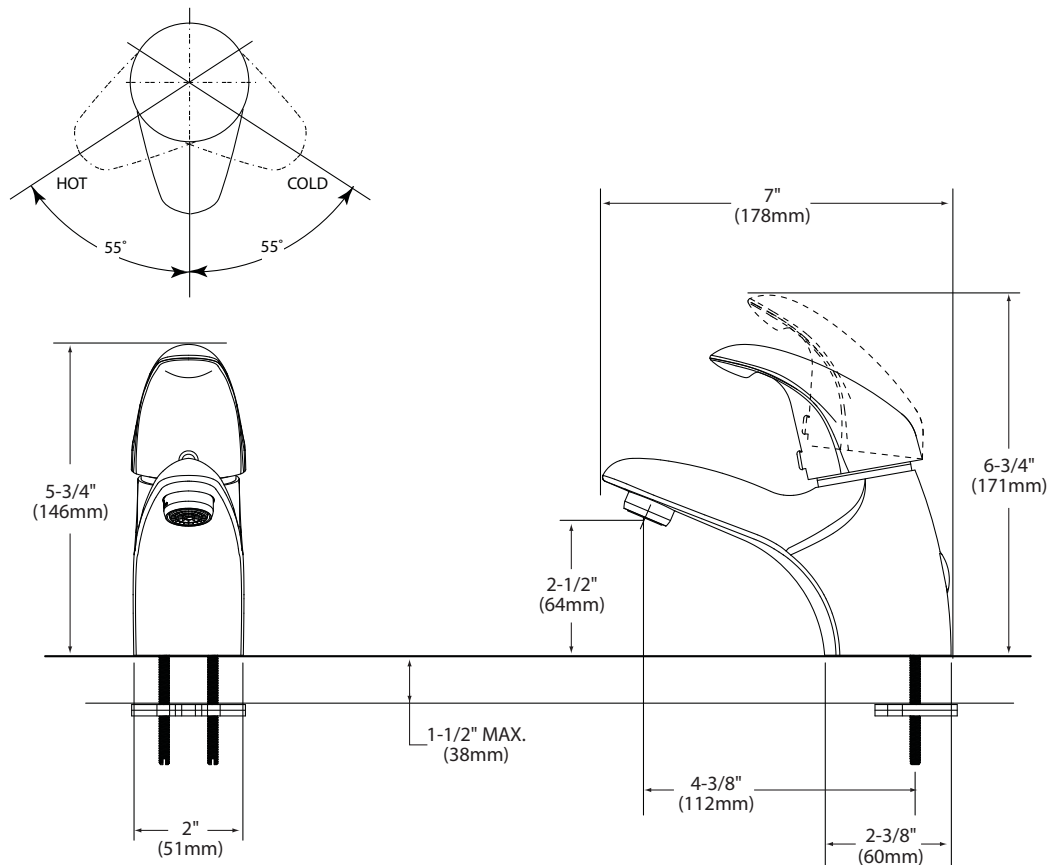

## CRITICAL DIMENSIONS

(DO NOT SCALE)