

MAAX SUBMITTAL SPECIFICATIONS

Vivez l'expérience

MAAX®

Enjoy the experience

Optik 7242

MODEL NUMBER 101275

DIMENSIONS: 72" x 42" x 23" Acrylic



STANDARD FEATURES

- Post-minimalism design combines straight and curvaceous lines for comfort
- Unique backrest
- Curvaceous armrests
- Deep bathing well
- Deck for faucet
- 2 12-inch metal grab bars optional Specify the grab bar position.
- Magnetic cushion optional available in black or white Magnet backed headrest for cushion. Factory installed only if cushion ordered on initial order.
- Central drain
- 1 design, 2 installations: undermount or drop-in

OPTIONS

- Thermo-Acoustic system
- Trim kit for Whirlpool and combined systems
- Water heater assembly
- Two 12-in. grab bars available in many colors
- Two chromatherapy lights
- Flexible main hose 15 ft for electronic control

UNIQUE FEATURES

- None

SYSTEMS



Aerofeel

CERTIFICATIONS

Maax products adhere to one or more of the following certifications: Aerofeel/Hydrofeel



Hydrofeel REST

2013-02-25

Project :

Contractor :

MAAX Representative : Tel :

Date :

www.maax.com

DOOR SELECTION

MAAX SUBMITTAL SPECIFICATIONS

Optik 7242

MODEL NUMBER 101275

TECHNICAL DRAWINGS

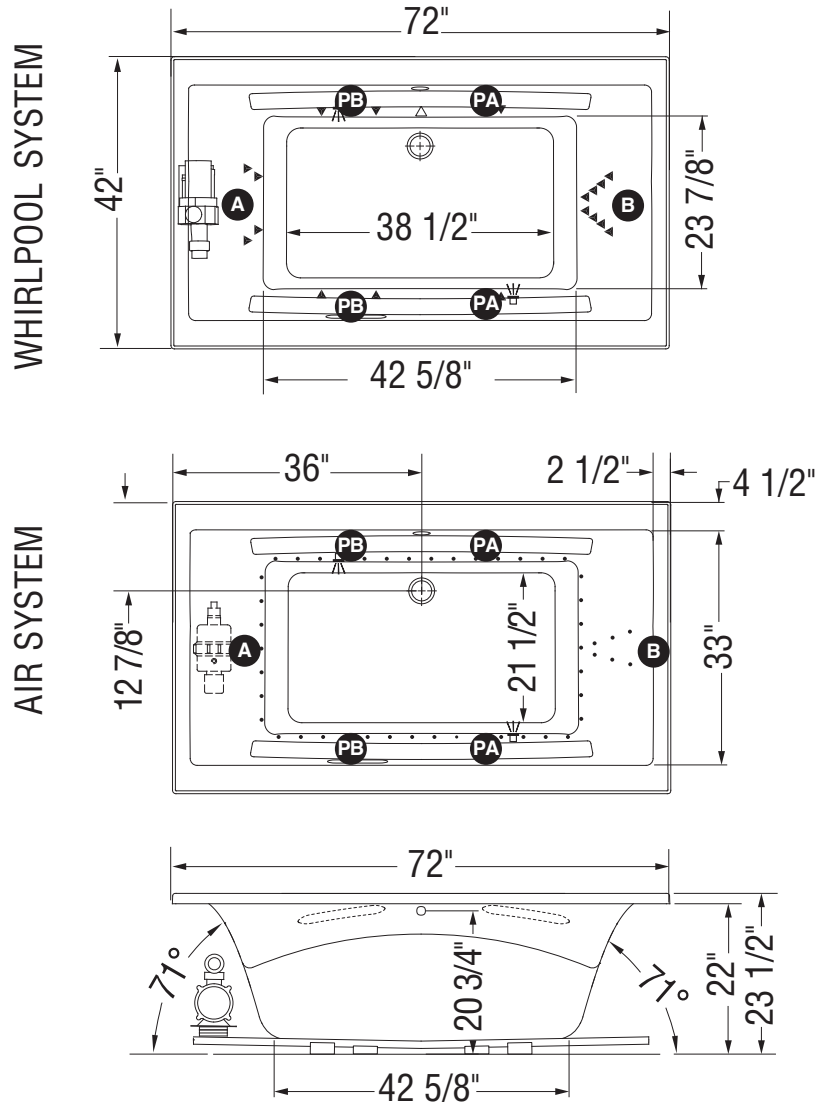

(A) : Specify blower and/or pump location when ordering
 (B)

(PA) : With system, the optional grab bar is on opposite side of the pump.
 (PB) Without system, specify optional grab bar location when ordering.

(▲) : Indicates whirlpool jets positioning

(△) : Indicates suction positioning

(•) : Indicates airjets positioning

(♪) : Indicates chromatherapy light positioning

Bathtub base includes anti-vibration Neutra-Phone leg supports (not shown).

All dimensions are approximate. Structure measurements must be verified against the unit to ensure proper fit.