

STEAM GENERATOR K-1734

Features

- 3-year warranty from date of installation
- Steam generators can be installed up to 25' (7.6 m) away from steam bath area

Codes/Standards Applicable

Specified model meets or exceeds the following:

- UL 499
- CSA C22.2 No. 88

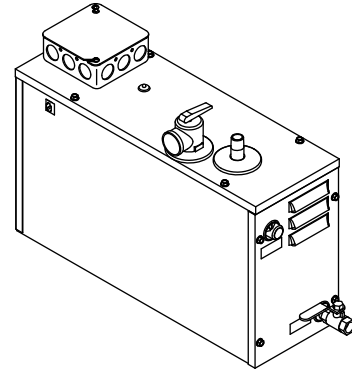

Colors/Finishes

- NA: None applicable

Accessories

- CP: Polished Chrome
- PB: Vibrant® Polished Brass
- Other: Refer to Price Book for additional colors/finishes

Specified Model

Model	Description	Colors/Finishes
K-1734	11 kW Fast-Response® steam generator	<input type="checkbox"/> NA

Required Accessories: Choose either Option 1 or Option 2 below.

Option 1:

K-1647-PC	Steam control kit, power clean	<input type="checkbox"/> CP	<input type="checkbox"/> PB	<input type="checkbox"/> Other_____
-----------	--------------------------------	-----------------------------	-----------------------------	-------------------------------------

Option 2:

K-1737	Steam adaptor kit and steam head AND	<input type="checkbox"/> CP	<input type="checkbox"/> PB	<input type="checkbox"/> Other_____
K-694	Landscape digital interface OR			<input type="checkbox"/> Other_____
K-695	Portrait digital interface			<input type="checkbox"/> Other_____

Optional Accessories: Only available for use with Option 2 above.

K-657	Landscape auxiliary digital interface	<input type="checkbox"/> Other_____
K-658	Portrait auxiliary digital interface	<input type="checkbox"/> Other_____

Product Specification

The 11 kW steam generator shall have a three-year warranty from date of installation. Product shall be installed up to 25' (7.6 m) away from the steam bath area. Steam generator shall be Kohler Model K-1734-NA.

Technical Information

Water and drain requirements:	
Water supply	3/8" line, 3/8" NPT female thread
Steam line	1/2" copper line, 1/2" NPT female thread
Pressure relief valve	3/4" NPT male thread, valve supplied
Drain line	3/8" line, 3/8" NPT male thread, ball valve supplied
Generator:	
Weight	19-1/2 lbs (8.8 kg)
Electrical rating	240 V, 46 A, 50/60 Hz

Required Electrical Service

Dedicated circuit required:	
Generator	240 V, 60 A, 50/60 Hz

Installation Notes

Install this product according to the installation guide.

Factory sized: L x H x W = cubic feet. Choose the appropriate model. For every foot of ceiling height over 8 ft (2.4 m), use the next larger steam unit. Always round your measurements up. Wall material is irrelevant for sizing.

For this steam generator, enclosure shall not exceed the maximum volume rating:

Steam generator model	Power rating	Maximum volume rating
K-1734	11 kW	317 cu ft (9 cu m)

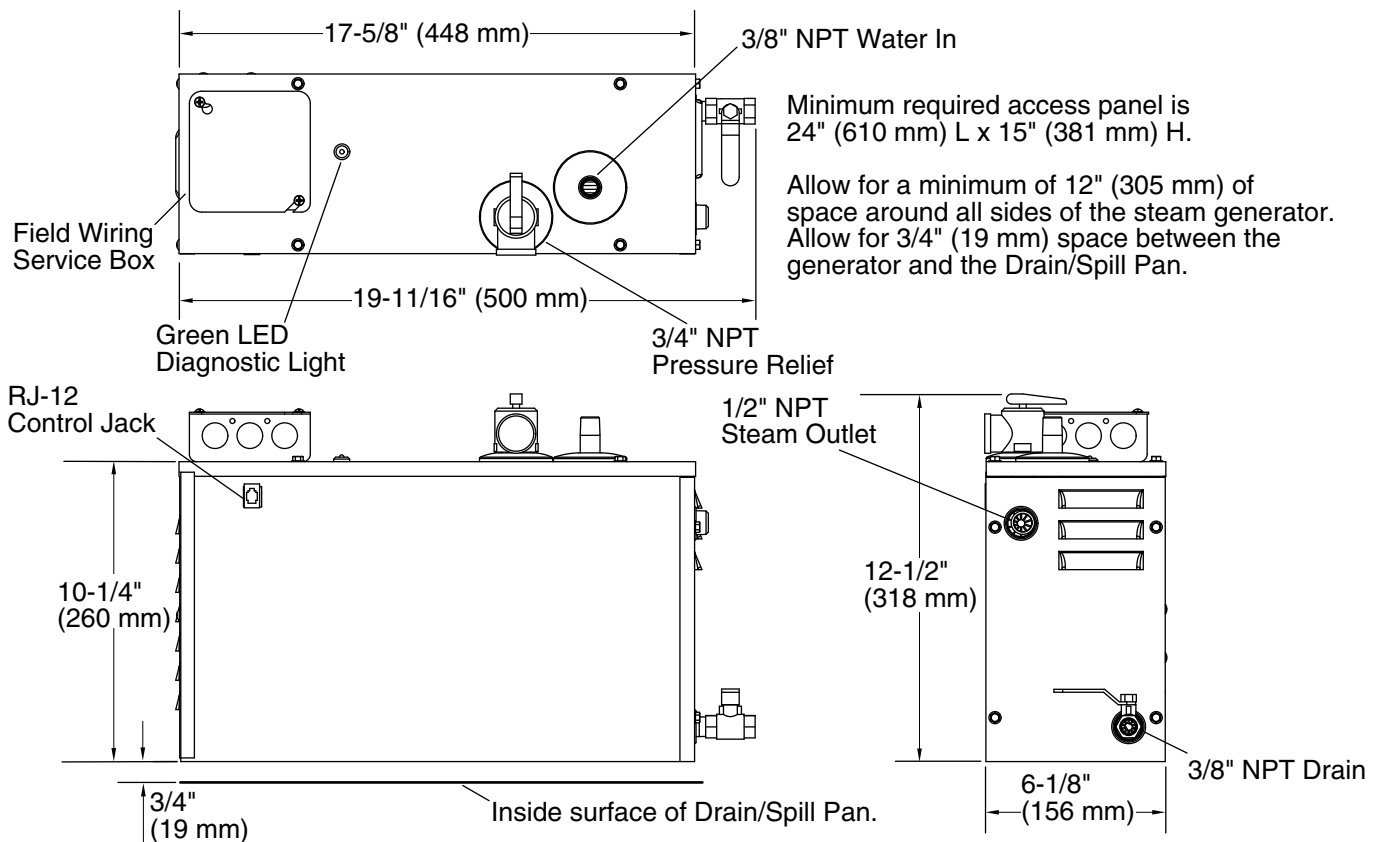

Product Diagram