

STEAM GENERATOR K-1733-NA

Features

- 3 year warranty
- Steam generators can be installed up to 25' (7.6 m) away from steam bath area

Codes/Standards Applicable

Specified model meets or exceeds the following:

- UL 499
- CSA C22.2 No. 88

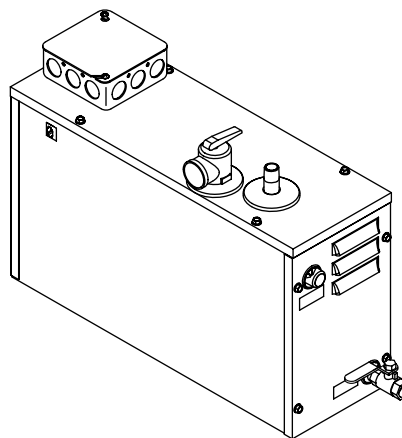

Colors/Finishes

- NA: None applicable

Accessories:

- CP: Polished Chrome
- PB: Polished Brass
- Other: Refer to Price Book for additional colors/finishes

Specified Model

Model	Description	Colors/Finishes		
K-1733-NA	Steam generator, 9 kW, fast response	<input type="checkbox"/> NA		
Required Accessories: Choose either Option 1 or Option 2 below.				
<i>Option 1:</i>				
K-1647-PC	Steam control kit, power clean	<input type="checkbox"/> CP	<input type="checkbox"/> PB	<input type="checkbox"/> Other_____
<i>Option 2:</i>				
K-1737	Steam adaptor kit and steam head AND	<input type="checkbox"/> CP	<input type="checkbox"/> PB	<input type="checkbox"/> Other_____
K-694	Landscape digital interface OR			<input type="checkbox"/> Other_____
K-695	Portrait digital interface			<input type="checkbox"/> Other_____
Optional Accessories: Only available for use with Option 2 above.				
K-657	Landscape auxiliary digital interface			<input type="checkbox"/> Other_____
K-658	Portrait auxiliary digital interface			<input type="checkbox"/> Other_____

Product Specification:

The 9 kW steam generator shall have a three-year warranty. Product shall be installed up to 25' (7.6 m) away from the steam bath area. Steam generator shall be Kohler Model K-1733-NA.

Technical Information

Water and drain requirements:	
Water supply	3/8" copper line, 3/8" NPT female thread
Steam line	1/2" copper line, 1/2" NPT female thread
Pressure relief valve	3/4" NPT female thread, valve supplied
Drain line	3/8" copper line, 3/8" NPT female thread, ball valve supplied
Generator:	
Weight	19-1/2 lbs (8.8 kg)
Electrical rating	240 V, 50/60 Hz, 50 A

Required Electrical Service

Dedicated circuit required:	
Generator	9 kW, 240 V, 50/60 Hz, 50 A

Installation Notes

Install this product according to the installation guide.

Factory sized: L x H x W = cubic feet. Choose the appropriate model. For every foot of ceiling height over 8 ft (2.4 m), use the next larger steam unit. Always round your measurements up. Wall material is irrelevant.

For this steam generator, do not exceed the maximum volume rating:

Steam generator model	Power rating	Maximum volume rating
K-1733-NA	9 kW	240 cu ft (6.8 cu m)

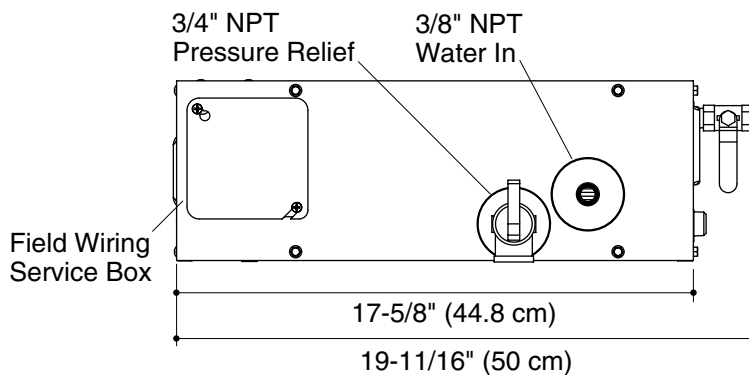

Minimum required access is 20" (50.8 cm) L x 13" (33 cm) H x 6-1/2" (16.5 cm) W.

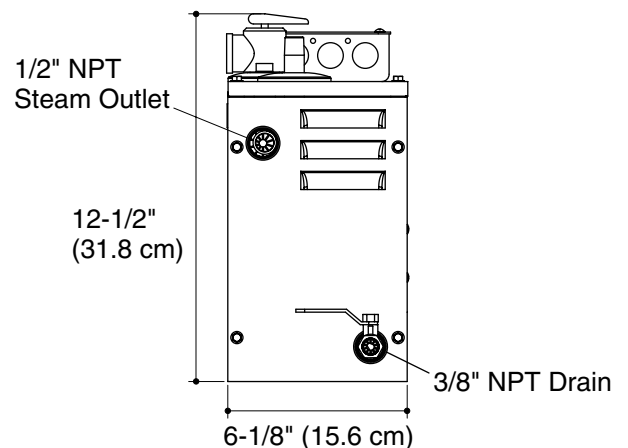
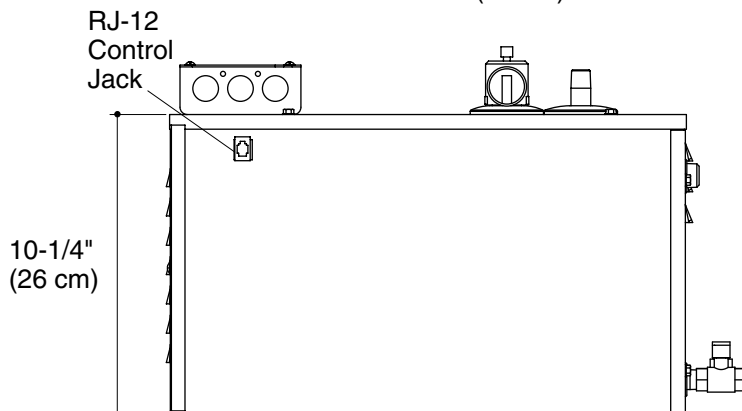

Product Diagram