

### Product Information

Applicable products:	
Steam generator	K-1652 (shown)
Steam assembly and control panel	K-1663 (required)
Water and drain requirements:	
Water supply	3/8" copper line, 3/8" NPT female thread
Steam line	1/2" copper line, 1/2" NPT female thread
Pressure relief valve	3/4" NPT female thread, valve supplied
Drain line	3/8" copper line, 3/8" NPT female thread, ball valve supplied
Generator:	
Weight	19-1/2 lbs (8.8 kg)
Electrical rating	240 V, 60 Hz, 25 A

### Required Electrical Service

Dedicated circuit required:	
Generator	5 kW, 240 V, 30 A, 60 Hz

### Installation Notes

Install this product according to the installation guide.

Fixture dimensions are nominal.

Factory sized: L x H x W = cubic feet. Choose the appropriate model. For every foot of ceiling height over 8 ft (2.4 cm), use the next larger steam unit. Always round your measurements up. Wall material is irrelevant.

For this steam generator, do not exceed the maximum volume rating:

Steam generator model	Power rating	Maximum volume rating
K-1652	5 kW	56 cu ft (1.6 cu m)

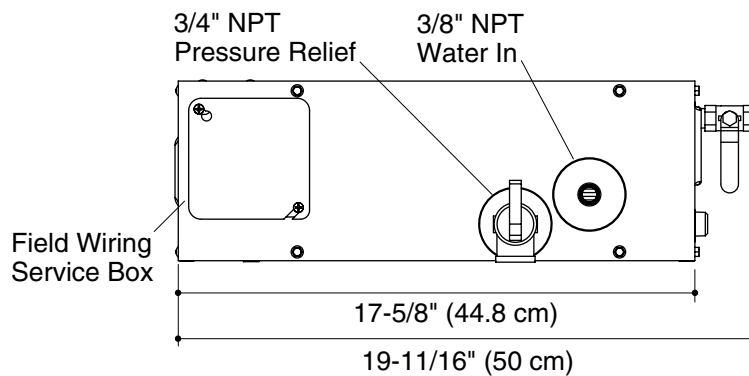

Minimum required access is 20" (50.8 cm) L x 13" (33 cm) H x 6-1/2" (16.5 cm) W.

