

**SPECIFICATION:**

JOSAM 12000-XSD SERIES COATED CAST IRON HORIZONTAL 4" NO-HUB FITTING WITH 2" NO-HUB VENT AND ADJUSTABLE CARRIER BODY, INVERTIBLE FOR SIPHON JET OR BLOWOUT CLOSETS, WITH ABS EXTENSION WITH INTEGRAL TEST CAP, PYLON FEET, ANCHOR FOOT, ANGLE SUPPORT, THREADED ROD, PLATED HARDWARE AND NEOPRENE FIXTURE GASKET.

**BARIATRIC CARRIER**  
(LEFT HAND SHOWN)

SERIES **12000-XSD**

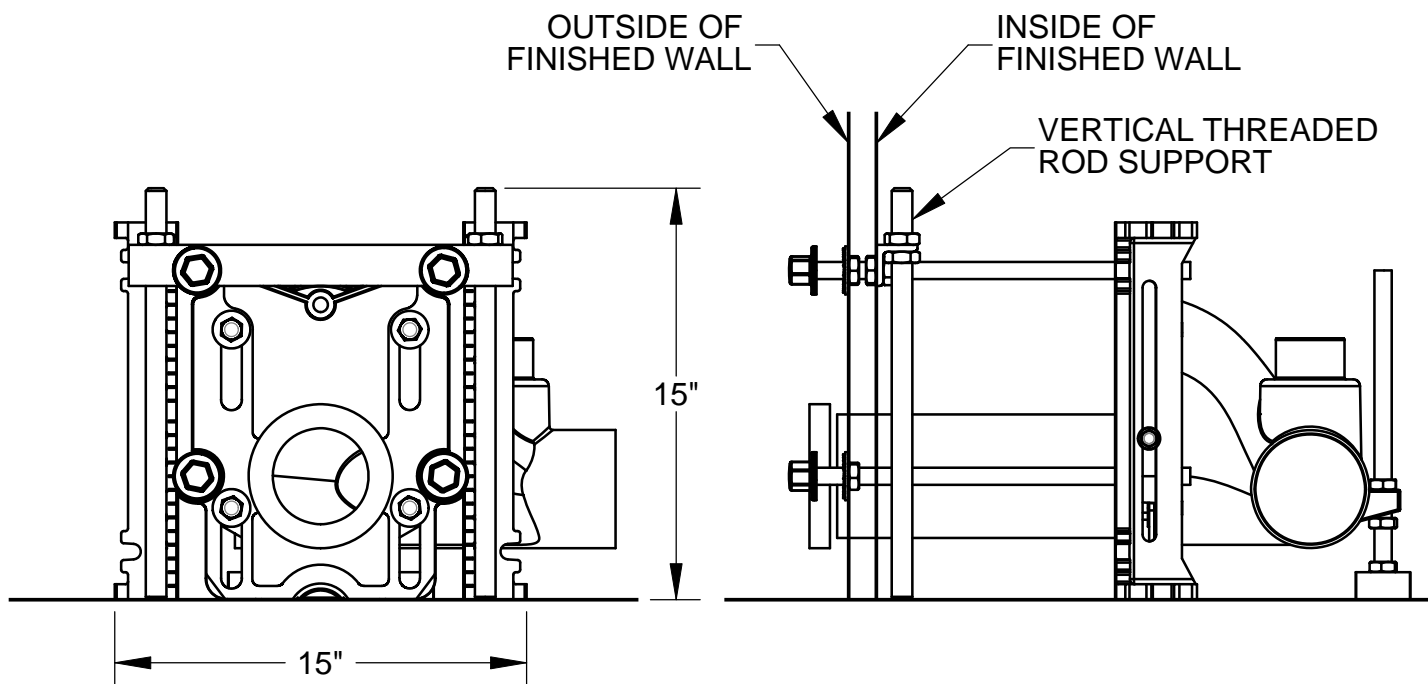
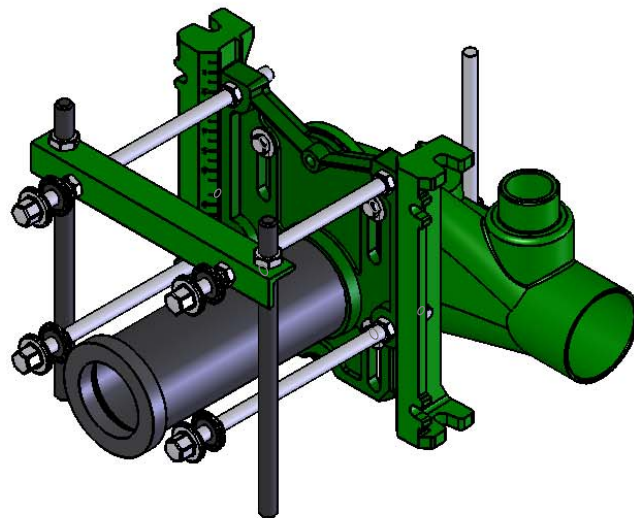
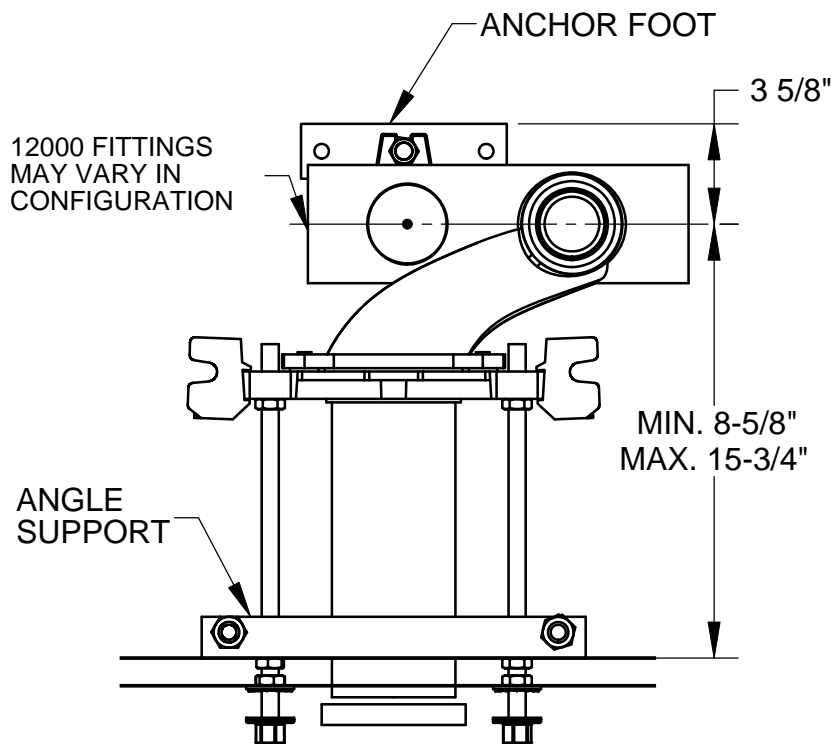

RECOMMEND CONCRETE ANCHORS WITH 750 LBS. PULL-OUT FORCE EACH.

THIS PRODUCT MEETS OR EXCEEDS THE REQUIREMENTS OF ANSI A112.6.1M-1997 WHEN TESTED AT 1,000 POUNDS.

DATE OF LAST CHANGE: 10/27/2010

DIMENSIONS ARE SUBJECT TO MANUFACTURERS TOLERANCES AND CHANGE WITHOUT NOTICE. WE CAN ASSUME NO RESPONSIBILITY FOR USE OF SUPERSEDED OR VOID DATA.

**JOSAM COMPANY**  
MICHIGAN CITY, INDIANA

NOTES